



Auto-Clean Optical Dissolved Oxygen System

(Q46D SOFTWARE VERSIONS .20 AND HIGHER)

Home Office

Analytical Technology, Inc.
6 Iron Bridge Drive
Collegeville, PA19426

Ph: 800-959-0299
610-917-0991

Fax: 610-917-0992

Email: sales@analyticaltechnology.com

European Office

ATI (UK) Limited
Unit 1 & 2 Gatehead Business Park
Delph New Road, Delph
Saddleworth OL3 5DE

Ph: +44 (0)1457-873-318

Fax: + 44 (0)1457-874-468

Email: sales@atiuk.com

PRODUCT WARRANTY

Analytical Technology, Inc. (Manufacturer) warrants to the Customer that if any part(s) of the Manufacturer's equipment proves to be defective in materials or workmanship within the earlier of 18 months of the date of shipment or 12 months of the date of start-up, such defective parts will be repaired or replaced free of charge. Inspection and repairs to products thought to be defective within the warranty period will be completed at the Manufacturer's facilities in Collegetown, PA. Products on which warranty repairs are required shall be shipped freight prepaid to the Manufacturer. The product(s) will be returned freight prepaid and allowed if it is determined by the manufacturer that the part(s) failed due to defective materials or workmanship.

This warranty does not cover consumable items, batteries, or wear items subject to periodic replacement including lamps and fuses.

Gas sensors carry a 12 months from date of shipment warranty and are subject to inspection for evidence of misuse, abuse, alteration, improper storage, or extended exposure to excessive gas concentrations. Should inspection indicate that sensors have failed due to any of the above, the warranty shall not apply.

The Manufacturer assumes no liability for consequential damages of any kind, and the buyer by acceptance of this equipment will assume all liability for the consequences of its use or misuse by the Customer, his employees, or others. A defect within the meaning of this warranty is any part of any piece of a Manufacturer's product which shall, when such part is capable of being renewed, repaired, or replaced, operate to condemn such piece of equipment.

This warranty is in lieu of all other warranties (including without limiting the generality of the foregoing warranties of merchantability and fitness for a particular purpose), guarantees, obligations or liabilities expressed or implied by the Manufacturer or its representatives and by statute or rule of law.

This warranty is void if the Manufacturer's product(s) has been subject to misuse or abuse, or has not been operated or stored in accordance with instructions, or if the serial number has been removed.

Analytical Technology, Inc. makes no other warranty expressed or implied except as stated above.

Table of Contents

| | |
|--|---|
| <ul style="list-style-type: none"> Part 1 - Introduction 5 <ul style="list-style-type: none"> 1.1 General 5 1.2 Standard System..... 5 1.3 Features 6 1.4 Q46D Q-Blast System Specifications 9 1.5 Q46D Performance Specifications (includes sensor)..... 10 1.6 Q-Blast Assembly 10 Part 2 - Mechanical Installation..... 11 <ul style="list-style-type: none"> 2.1 General 11 2.2 Wall or Pipe Mount 12 2.3 Wall Mount Dimensions..... 13 2.4 Railing Mount 15 2.5 Sensor Installation..... 16 Part 3 - Electrical Installation 18 <ul style="list-style-type: none"> 3.1 General 18 3.2 Power Connections 18 3.3 Sensor Connections 20 3.4 Q-Blast to Q46 Connection .. 22 3.5 Analog Output Connections . 25 3.6 Relay Connections 25 Part 4 - Optical D.O. Sensor..... 26 <ul style="list-style-type: none"> 4.1 General 26 4.2 Optical Sensing 27 Part 5 - Operation 28 <ul style="list-style-type: none"> 5.1 User Interface..... 28 <ul style="list-style-type: none"> 5.11 Keys..... 29 5.12 Display 29 5.2 Software 31 <ul style="list-style-type: none"> 5.21 Software Navigation..... 31 5.22 Measure Menu [MEASURE]. 34 5.23 Calibration Menu [CAL] 35 5.24 Configuration Menu [CONFIG] <ul style="list-style-type: none"> 36 5.25 Control Menu [CONTROL] ... 40 5.26 Diagnostics Menu [DIAG] . 46 | <ul style="list-style-type: none"> Part 6 - Calibration..... 51 <ul style="list-style-type: none"> 6.1 General 51 6.2 D.O. Span Cal (1-spl) 51 6.3 D.O. Span Air Cal (%-sat) 53 6.4 D.O. ZeroCal 54 6.5 Temperature Calibration..... 56 Part 7 - Sensor Auto-Clean System.... 57 <ul style="list-style-type: none"> 7.1 General 57 7.2 Cleaner Sequence..... 58 Part 8 - PID Controller Details 59 <ul style="list-style-type: none"> 8.1 PID Description 59 8.2 PID Algorithm 59 8.3 Classical PID Tuning 61 8.4 Manual PID Override Control 62 8.5 Common PID Pitfalls 62 Part 9 - System Maintenance 64 <ul style="list-style-type: none"> 9.1 General 64 9.2 Analyzer Maintenance..... 64 9.3 Sensor Maintenance 64 Part 10 - Troubleshooting 65 <ul style="list-style-type: none"> 10.1 General 65 10.2 External Problem Sources.... 65 10.3 Analyzer 67 10.4 Sensor Tests 70 Spare Parts..... 72 |
|--|---|

Table of Figures

| | |
|--|----|
| <i>Figure 1 - D.O. System w/Auto-Clean Sensor</i> | 8 |
| <i>Figure 2 - Wall Mount Bracket</i> | 12 |
| <i>Figure 3 - Wall Mount Analyzer Dimensions</i> | 13 |
| <i>Figure 4 - Cleaner Enclosure Dimensions</i> | 14 |
| <i>Figure 5 - Handrail Mounting Assembly</i> | 15 |
| <i>Figure 6 -Sensor Mounting Assembly</i> | 16 |
| <i>Figure 7 - Sensor Mounting Detail</i> | 17 |
| <i>Figure 8 - Q46D Connections</i> | 19 |
| <i>Figure 9 - Q-Blast Connections</i> | 20 |
| <i>Figure 10 - Sensor Wiring</i> | 21 |
| <i>Figure 11 - Electrical Connections</i> | 23 |
| <i>Figure 12 - Q-blast Connections w/Optional J-Box</i> | 24 |
| <i>Figure 13 - Submersible D.O. Sensor Assy</i> | 26 |
| <i>Figure 14 - Optical Sensor Element</i> | 27 |
| <i>Figure 15 - User Interface</i> | 28 |
| <i>Figure 16 - Software Map</i> | 33 |
| <i>Figure 17 - Control Relay, Hysteresis & Phase Options</i> | 43 |
| <i>Figure 18 - Alarm Relay Example</i> | 44 |
| <i>Figure 19 - ISA PID Equation</i> | 60 |
| <i>Figure 20 - Q46D Display Messages</i> | 68 |
| <i>Figure 21 - Pt1000 RTD Table</i> | 70 |
| <i>Figure 22 - Reference, Barometric Conversion Table</i> | 71 |

Part 1 - Introduction

1.1 General

The Model Q46D is a versatile on-line monitoring system designed for the continuous measurement of dissolved oxygen in solution. The full scale operating range of the system 0-40 ppm, and the sensing system will operate on water streams with temperatures ranging from 0 to 50°C.

While the Q46D may be used with either optical oxygen or galvanic membrane sensors, this manual is specific for systems utilizing ATI's optical D.O. sensor.

Q46D Monitors are available in two electronic versions, an AC powered monitor with integral alarm relays and dual 4-20 mA output capability, and a 12-24 VDC unit with dual output and relays. An optional digital output is available for Profibus-DP, Modbus-RTU, or Ethernet-IP.

1.2 Standard System

The Model Q46D Auto-Clean system includes three main components, a NEMA 4X electronics unit, the "Q-Blast" NEMA 4X Air-Blast cleaning assembly, and a submersible optical D.O. sensor with cleaner nozzle. Sensors are design for direct immersion in an aeration tank or flowing stream. Optical sensors come with a standard 30 ft. cable and connect directly to the Q46D monitor. Sensors with special cable lengths are available. A separate tubing connection located on the Q-Blast assembly is provided for connection of a 30 foot length of plastic tubing (supplied with the unit). A typical system is shown in Figure 1

Note that Figure 1 shows the D.O. Monitor and Q-Blast cleaner mounted on ATI's optional panel assembly with power distribution box. The panel and power distribution box are not part of standard systems, and must be ordered separately using part number (00-1637).

The D.O. sensor assembly is mounted to a 1" pipe using a special mounting adapter supplied as part of the 00-0624 mounting assembly. The 1" pipe is attached to the tank handrail with a bracket assembly that holds the sensor at a slight angle in the tank.

Once installed and placed into operation, the Q46D Auto-Clean D.O. system will provide months of reliable D.O. measurement in almost any application. Sensors should be checked for build-up after the first 3 months to verify that the cleaner is keeping the membrane clean. However, sensor maintenance intervals of 6 months or more are likely in most aeration tanks.

The sensor automatic cleaning frequency is user programmable, and units are shipped with a default cleaning frequency of once every 24 hours. This frequency has proven sufficient for most aeration applications, but can be increased if needed for a specific application. A cleaning frequency of more than every 2 hours is not recommended. Contact your ATI representative for more information if an 8-hour cleaning cycle does not keep the membrane clean

1.3 Features

- Standard Q46D electronic transmitters are designed to be fully isolated instruments for operation from either 90-260 VAC or 12-24 VDC power supplies.
- High accuracy, high sensitivity system, measures from 0.1 ppm to 40.0 ppm through 2 internal automatic ranges.
- Two 4-20 mA analog outputs are standard. One output may be configured to track D.O or as a PID control output, while the other output is programmable to track either D.O. or Temperature.
- Output Hold, Output Simulate, Output Alarm, and Output Delay Functions. All forced changes in output condition include bumpless transfer to provide gradual return to on-line signal levels and to avoid system control shocks on both analog outputs.
- Units provide three SPDT relay outputs and two isolated analog outputs. Software settings for relay control include setpoint, deadband, phase, delay, and failsafe. An additional bank of three low-power relays (0-30 VDC) is included for Q-Blast cleaner control.
- Large, high contrast, custom LCD display with LED back light provides excellent readability in any light conditions. The secondary line of display utilizes 5x7 dot matrix characters for clear message display two of four measured parameters may be on the display simultaneously.

- Diagnostic messages provide a clear description of any problem with no confusing error codes to look up. Messages are also included for diagnosing calibration problems.
- Quick and easy one-point calibration method, air calibration method, and sensor zero-cal. To provide high accuracy, all calibration methods include stability monitors that check temperature and main parameter stability before accepting data.
- High accuracy three-wire Pt1000 temperature input. Temperature element can be user calibrated.
- Security lock feature to prevent unauthorized tampering with transmitter settings. All settings can be viewed while locked, but they cannot be changed.



Equipment bearing this marking may not be discarded by traditional methods in the European community after August 12 2005 per EU Directive 2002/96/EC. End users must return old equipment to the manufacturer for proper disposal.

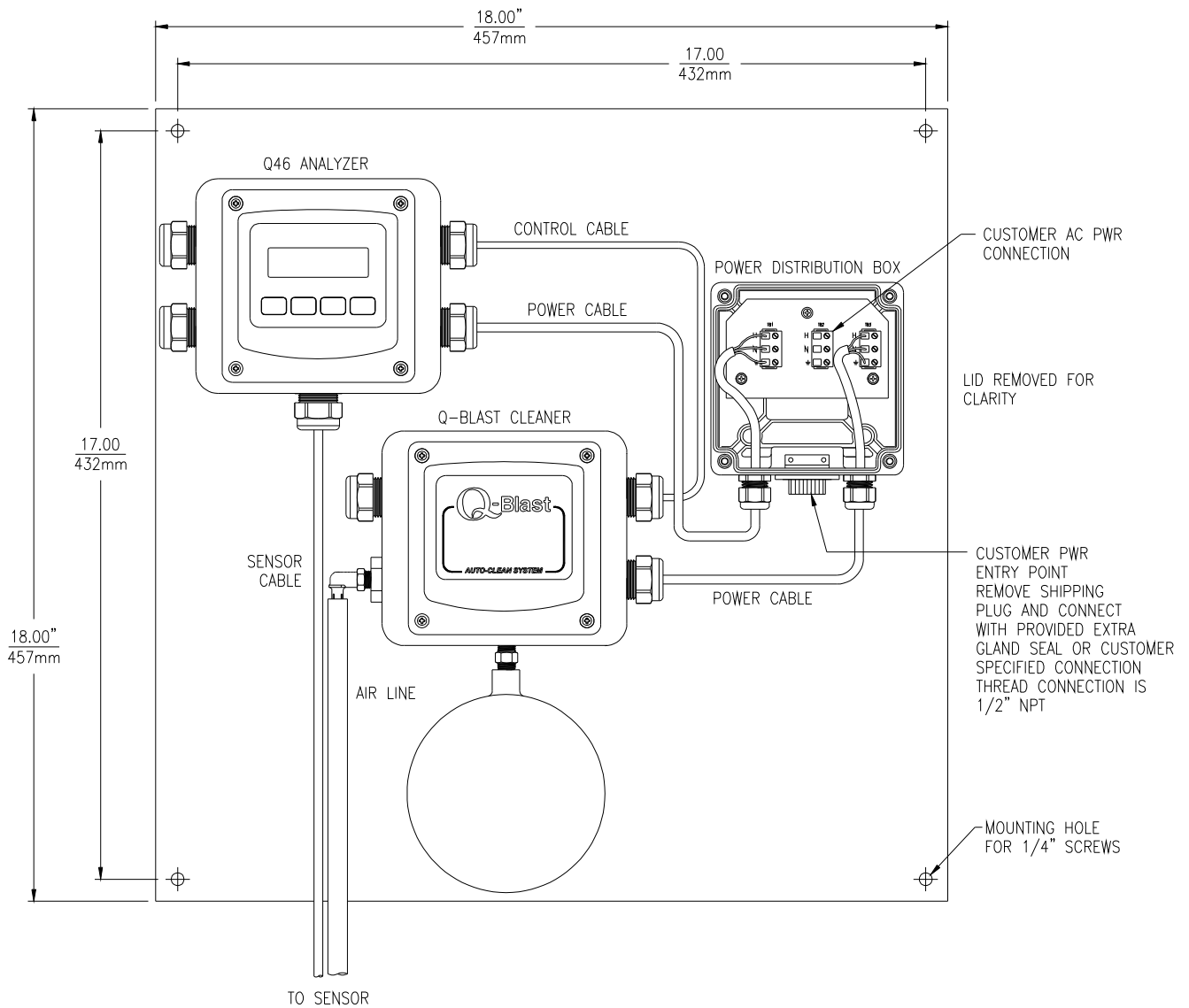

(System Diagram Shown on Optional Mounting Plate w/Power Distribution Box)

Figure 1 - D.O. System w/Auto-Clean Sensor

1.4 Q46D Q-Blast System Specifications

| | |
|-----------------------------------|--|
| Main Parameter Ranges | Manual selection of one of the following display ranges, 0.00 to 40.00 ppm or 0.00 to 40.00 mg/l 0.0 to 999.9% Saturation |
| Power | 90-260 VAC, 50/60 Hz., 10 VA Maximum or 12-24 VDC, 500 mA max. |
| Display | 0.75" (19.1 mm) high 4-digit main display with sign 12-digit secondary display, 0.3" (7.6 mm) 5x7 dot matrix. Integral LED back-light for visibility in the dark. |
| Enclosure | NEMA 4X, IP-66 polycarbonate, stainless steel hardware, |
| Analog Outputs | Two 4-20 mA outputs. Output one programmable for PPM D.O. or PID. Output 2 programmable for PPM D.O. or Temperature. Max load 450 Ohms for output 1 and 1000 ohms for output 2. Outputs ground isolated and isolated from each other. |
| Output Isolation | 600 V galvanic isolation |
| Optional Digital Output: | Profibus-DP, Modbus-RTU or Ethernet-IP available. |
| Relays, Electromechanical: | Three SPDT, 6 amp @ 250 VAC, 5 amp @ 24 VDC contacts. Software selection for setpoint, phase, delay, deadband, hi-lo alarm, and failsafe. A-B indicators on main LCD, and C indicator on lower display. Three additional low-power (0-30 VDC) relays are used to control the Q-Blast cleaner functions. |
| Weight | Electronics Assembly: 2.4lbs. (1.1 kg) Sensor Assembly: 3.5 lbs. (1.58 kg.) |
| Ambient Temperature | Analyzer Service, -20 to 60 °C (-4 to 140 °F) Sensor Service, -5 to 55°C (23 to 131 °F) Storage, -30 to 70 °C (-22 to 158 °F) |
| Ambient Humidity | 0 to 95%, non-condensing |
| Altitude | Up to 2000 m (6562 ft.) |
| Location | Designed for hazardous and non-hazardous areas |
| EMI/RFI Influence | Designed to EN 61326-1 |

| | |
|----------------------------------|--|
| Temperature Input | Pt1000 RTD for automatic compensation |
| Sensor | Optical oxygen sensor utilizing fluorescence quenching technology. Optical element life 3-5 years. |
| Sensor Materials | Noryl, PVC, and stainless steel |
| Sensor Cable | Submersible: 30 ft. (9.1 m) |
| Max. Sensor Cable Length: | 200 feet (61 m), with junction box |

1.5 Q46D Performance Specifications (includes sensor)

| | |
|-----------------------------|--|
| Accuracy | ±0.05 PPM or 0.5% of Span |
| Repeatability | 0.05 PPM |
| Sensitivity | 0.01 PPM |
| Electronic Stability | 0.05% of span per 24 hours, non-cumulative |
| Temperature Drift | Span or zero, 0.01% of span/°C |
| Response Time | 180 seconds to 90% of step input |

1.6 Q-Blast Assembly

| | |
|----------------------------|--|
| Power | 90- 260 VAC, 50/60 Hz., 10 VA Maximum 12-24 VDC, 500 mA max. |
| Enclosure | NEMA 4X, IP-66 polycarbonate, stainless steel hardware, |
| Compressor | 12 VDC Diaphragm Type, 28 PSI (1.9 Bar) Maximum |
| Heater | Internal thermostatically controlled. |
| Ambient Temperature | Operating, -40 to 60 °C (-40 to 140 °F) Storage, -40 to 70 °C (-40 to 158 °F) |
| Air Accumulator | Powder coated stainless steel |
| Weight | 3.7 lbs. (1.7 kg) |

Part 2 - Mechanical Installation

2.1 General

The Q46D Q-Blast D.O. System consists of two assemblies housed in NEMA 4X (IP-66) enclosures. The analyzer electronics and the Q-Blast cleaner assembly should both be mounted near the sensor location, with a maximum of 60 feet between the monitor/cleaner and the sensor. The standard system is supplied with a 30 ft. sensor cable and 30 feet of air line tubing. Best performance is obtained by keeping sensor cable and air tubing length as short as practical.

Installation of a complete Q46D Auto-Clean System requires mounting both the analyzer electronics and the cleaner assembly, mounting the sensor assembly, and running a 3-conductor interconnect wire between the analyzer and cleaner assemblies. Both the analyzer and the Q-Blast assembly require power connection. If the system is purchased with optional mounting plate and power distribution box, interconnect wiring will already be complete and only one power connection is required at the junction box.

The analyzer enclosure and the cleaner enclosure may be mounted to any flat surface, like a wall or plate. A bracket assembly is available (#00-0930) for mounting a flat PVC, aluminum, or stainless steel plate to hold the two enclosures to typical aeration handrail systems. This bracket locates the monitor at a convenient height for viewing the display and using the controls.

2.2 Wall or Pipe Mount

A PVC mounting bracket with attachment screws is supplied with each transmitter (see **Error! Reference source not found.** for dimensions). The multi-purpose bracket is attached to the rear of the enclosure using the four flat head screws. The instrument is then attached to the wall using the four outer mounting holes in the bracket. These holes are slotted to accommodate two sizes of u-bolt that may be used to pipe mount the unit. Slots will accommodate u-bolts designed for 1½ “or 2” pipe. The actual center to center dimensions for the u-bolts are shown in the drawing. Note that these slots are for u-bolts with ¼-20 threads. The 1½” pipe u-bolt (2” I.D. clearance) is available from ATI in type 304 stainless steel under part number (47-0004).

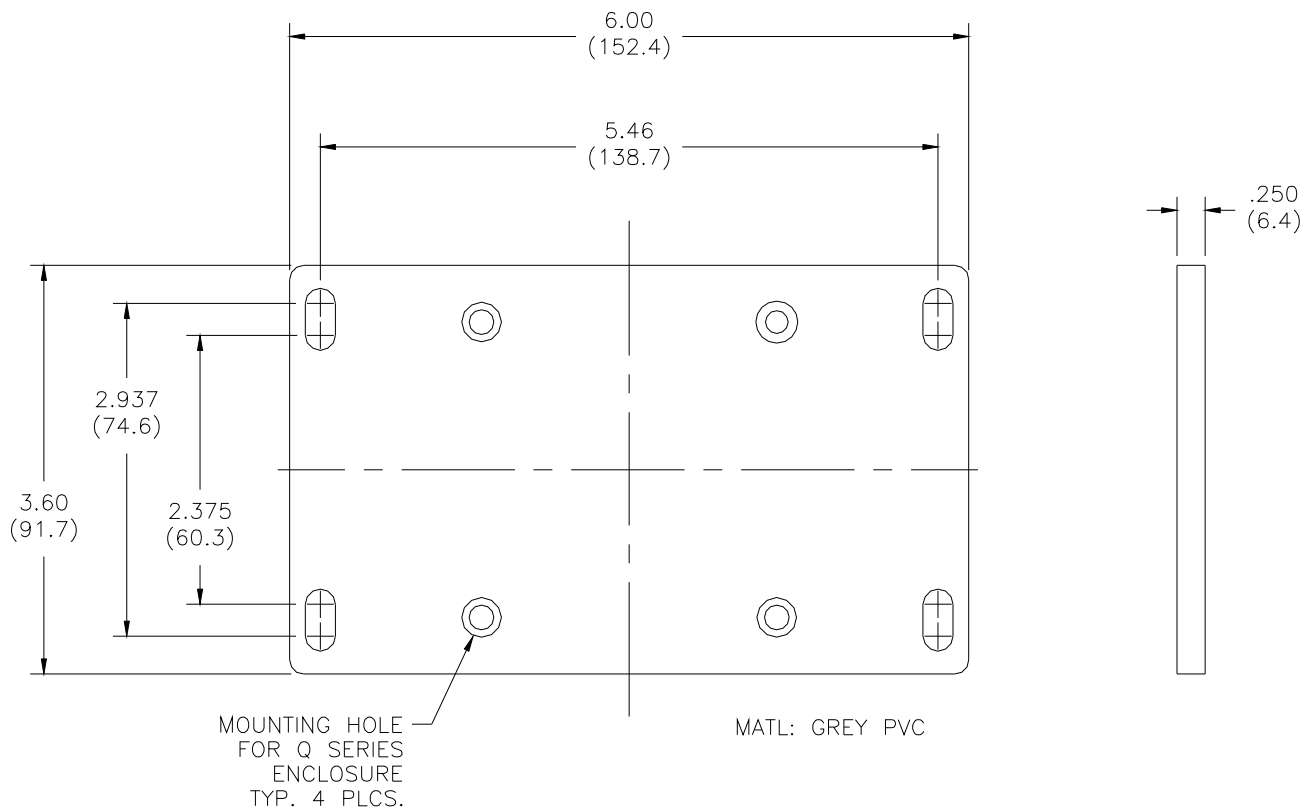

Figure 2 - Wall Mount Bracket

2.3 Wall Mount Dimensions

Figure 3 shows the dimensions of the analyzer dimensions. Note that the enclosure mounting brackets are not installed at the factory. They are supplied separately and must be attached using the screws provided. This is done to protect the brackets against shipping damage.

Figure 4 shows the dimensions of the Q-Blast assembly. This enclosure should be mounted beside the analyzer enclosure as shown in Figure 1. If the optional mounting plate and power junction box were purchased, the analyzer and cleaner will be supplied mounted to the plate.

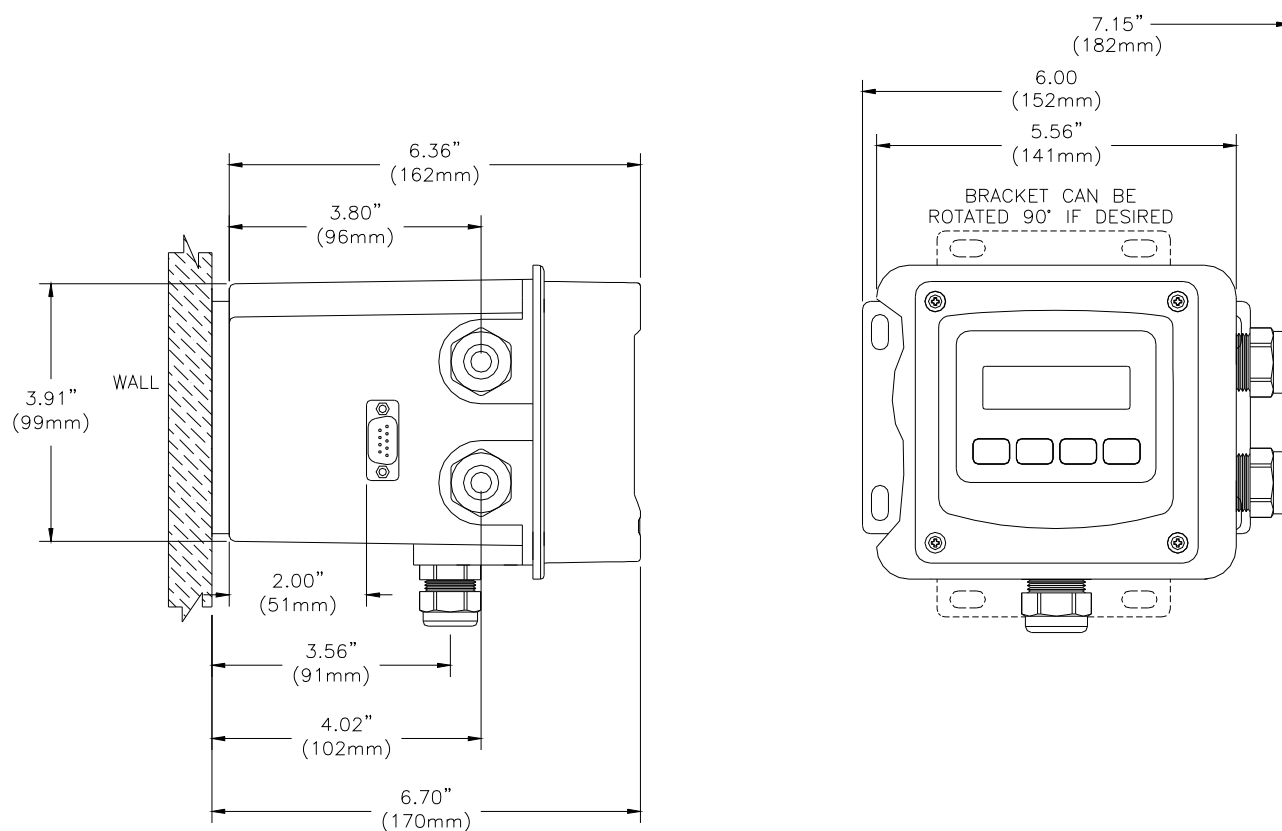

Figure 3 - Wall Mount Analyzer Dimensions

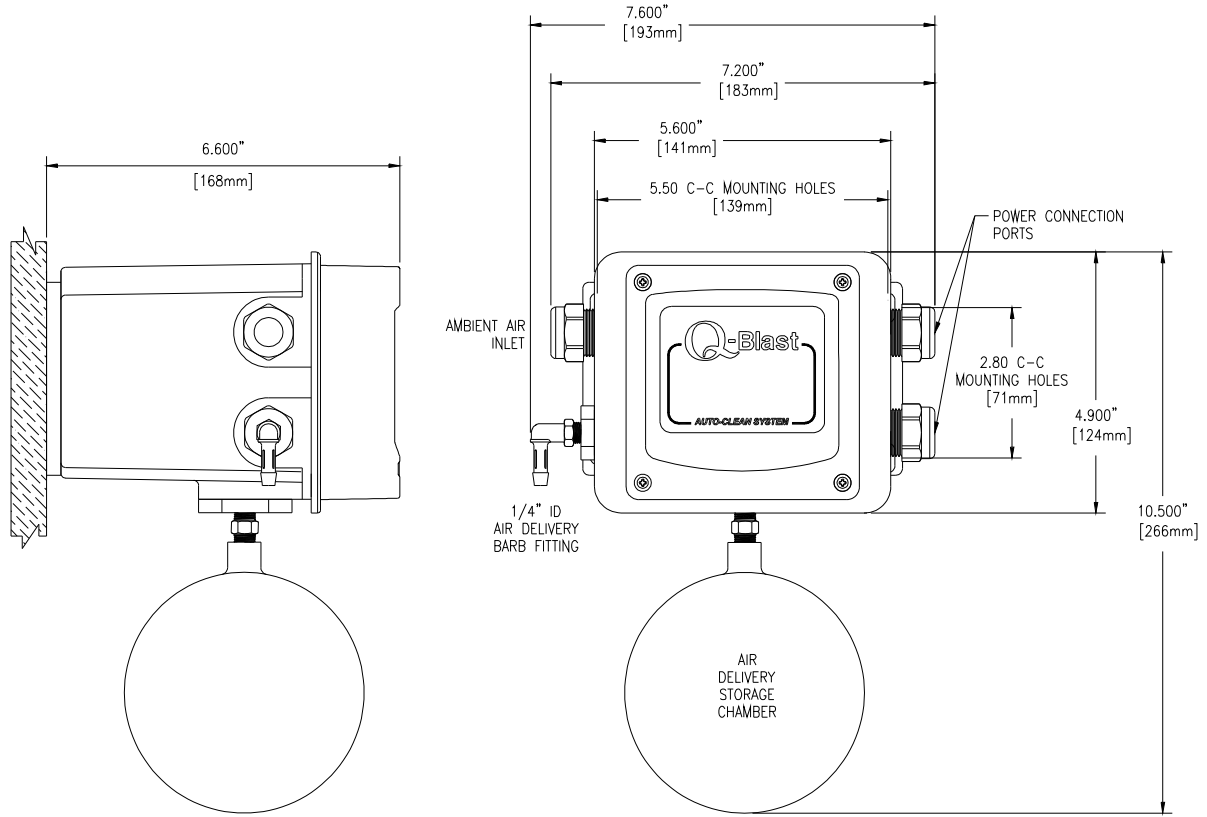

Figure 4 - Cleaner Enclosure Dimensions

2.4 Railing Mount

Figure 5 - Handrail Mounting Assembly shows the optional mounting assembly (on system mounting plate) used to mount the analyzer and cleaner assembly to a typical safety handrail that surrounds many aeration tanks. This bracket assembly consists of vertical channels attached to the handrail with u-bolts. The monitor screws to the channels with the 10-32 screws supplied as part of the kit. U-bolts for 2" diameter handrail pipe are also supplied.

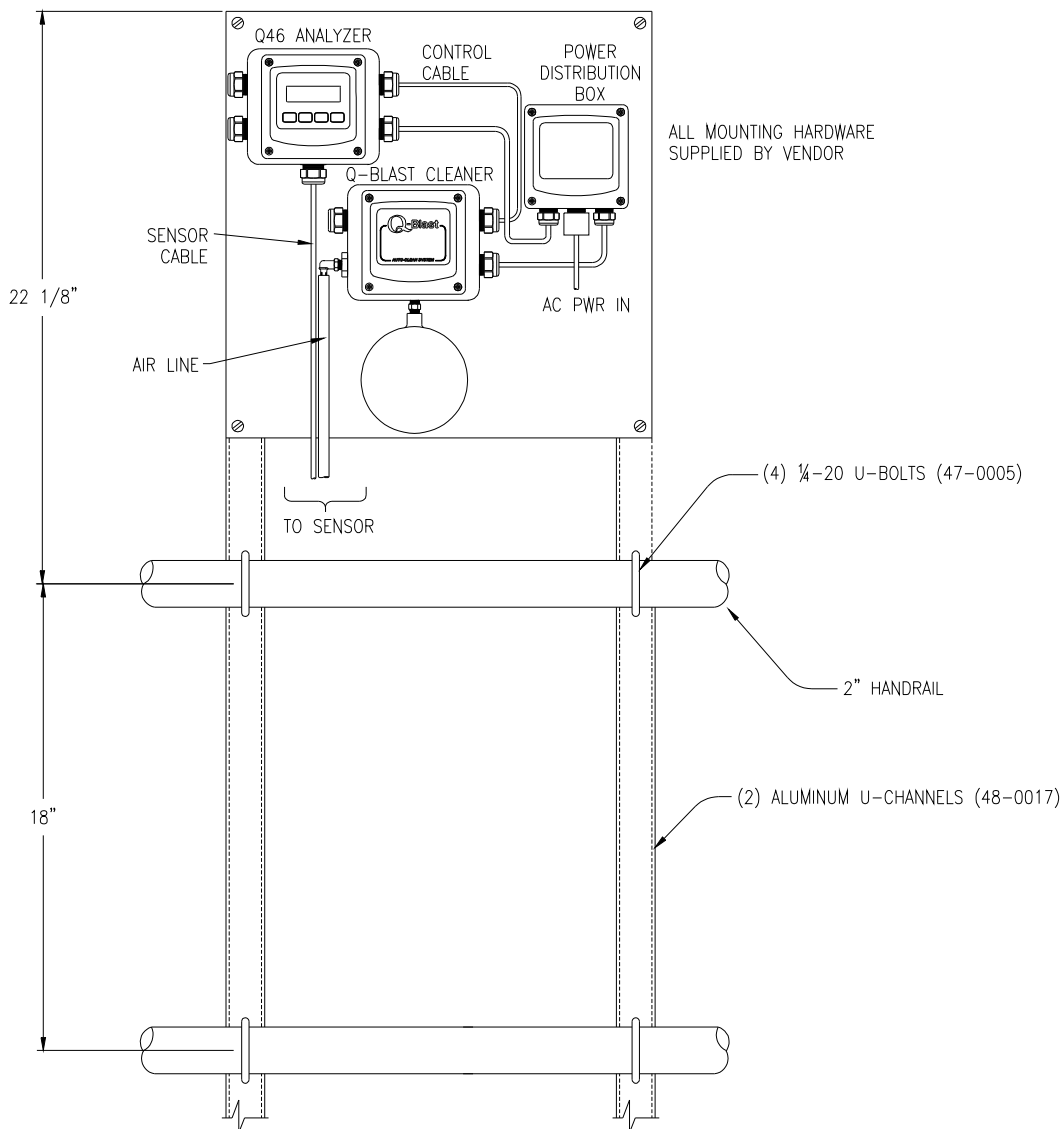

Figure 5 - Handrail Mounting Assembly

2.5 Sensor Installation

Most applications for D.O. monitoring are done using a submersible sensor. This method can be used where flow is reasonably constant, and hydraulic head does not vary more than about 10 feet. Oxygen sensors can never be used in completely stagnant conditions. A flow velocity of at least 0.3 feet per second is normally required for measurement.

Submersible sensors are mounted to a 1" pipe using a standard 1" PVC thread by thread pipe coupling. The mounting pipe can be secured to standard 1½" or 2" pipe rail using a mounting bracket kit available from ATI (part number 00-0628) as shown in Figure 6 & Figure 7.

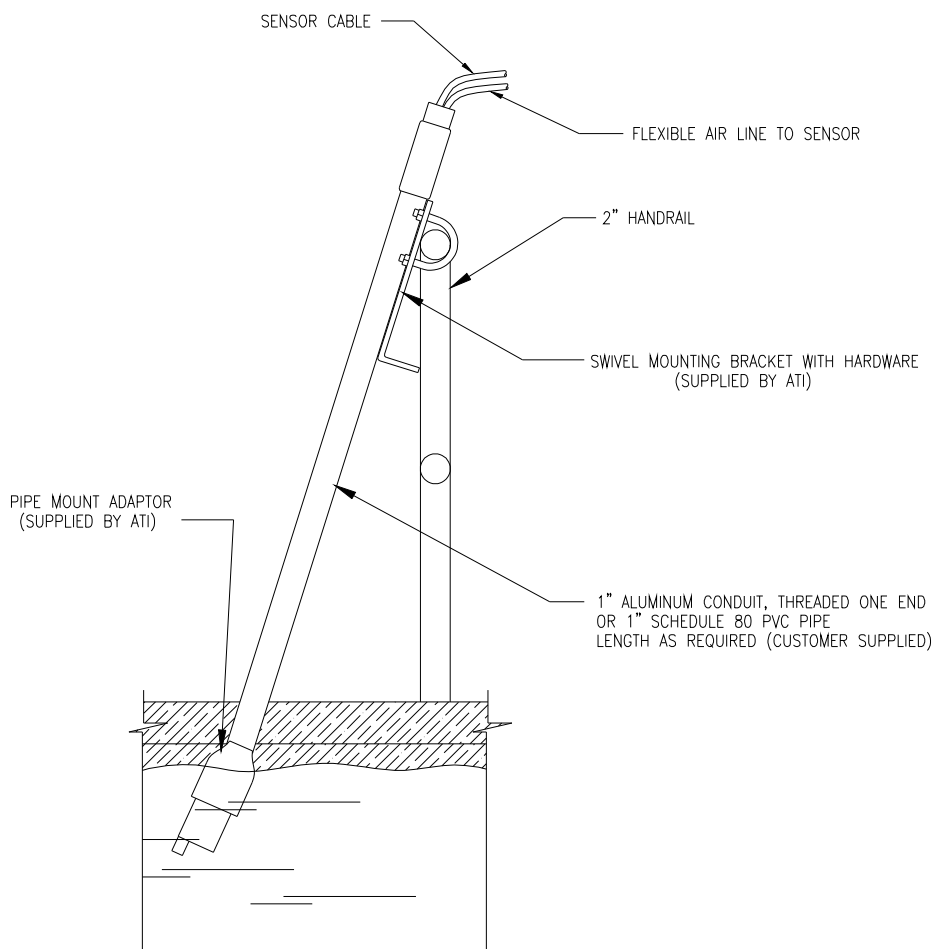

Figure 6 -Sensor Mounting Assembly

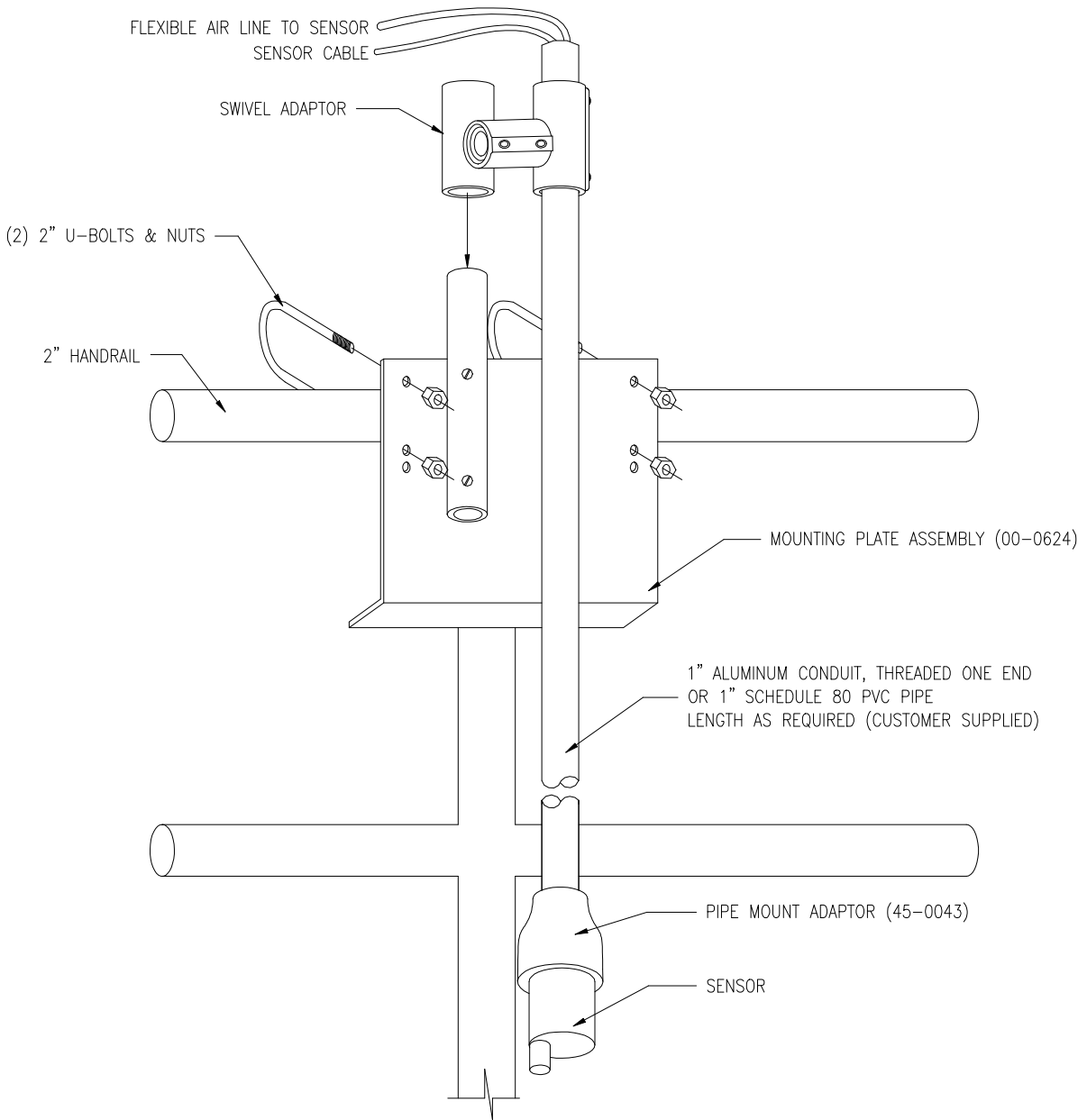

Figure 7 - Sensor Mounting Detail

Part 3 - Electrical Installation

3.1 General

Q46D/60 Auto-Clean D.O. monitors and Q-Blast cleaners are powered from 90-260 VAC, 50/60 Hz. or 12-24 VDC. Systems can draw up to 0.5 amps when the internal air compressor activates as part of the sensor cleaning system. Normal current draw is less than 0.2 amps when the cleaner is off.

Important Notes:

1. Use wiring practices that conform to all national, state and local electrical codes. For proper safety as well as stable measuring performance, it is important that the earth ground connection be made to a solid ground point from **TB1**.
2. Do NOT run sensor cables or instrument 4-20 mA output wiring in the same conduit that contains AC power wiring. AC power wiring should be run in a dedicated conduit to prevent electrical noise from coupling with the instrumentation signals.

3.2 Power Connections

Auto-Clean D.O. systems are generally AC powered, although a DC powered system is available. Power connections are made to terminal TB7 in the Q46D D.O. monitor (Figure 8) and to TB1 in the Q-Blast assembly (Figure 9).

AC or DC power should be brought into the enclosures through the bottom gland seal on the right side of the enclosure. This entry is directly above the power terminal blocks. Terminal blocks are pluggable, and can be removed for easy wire connection.

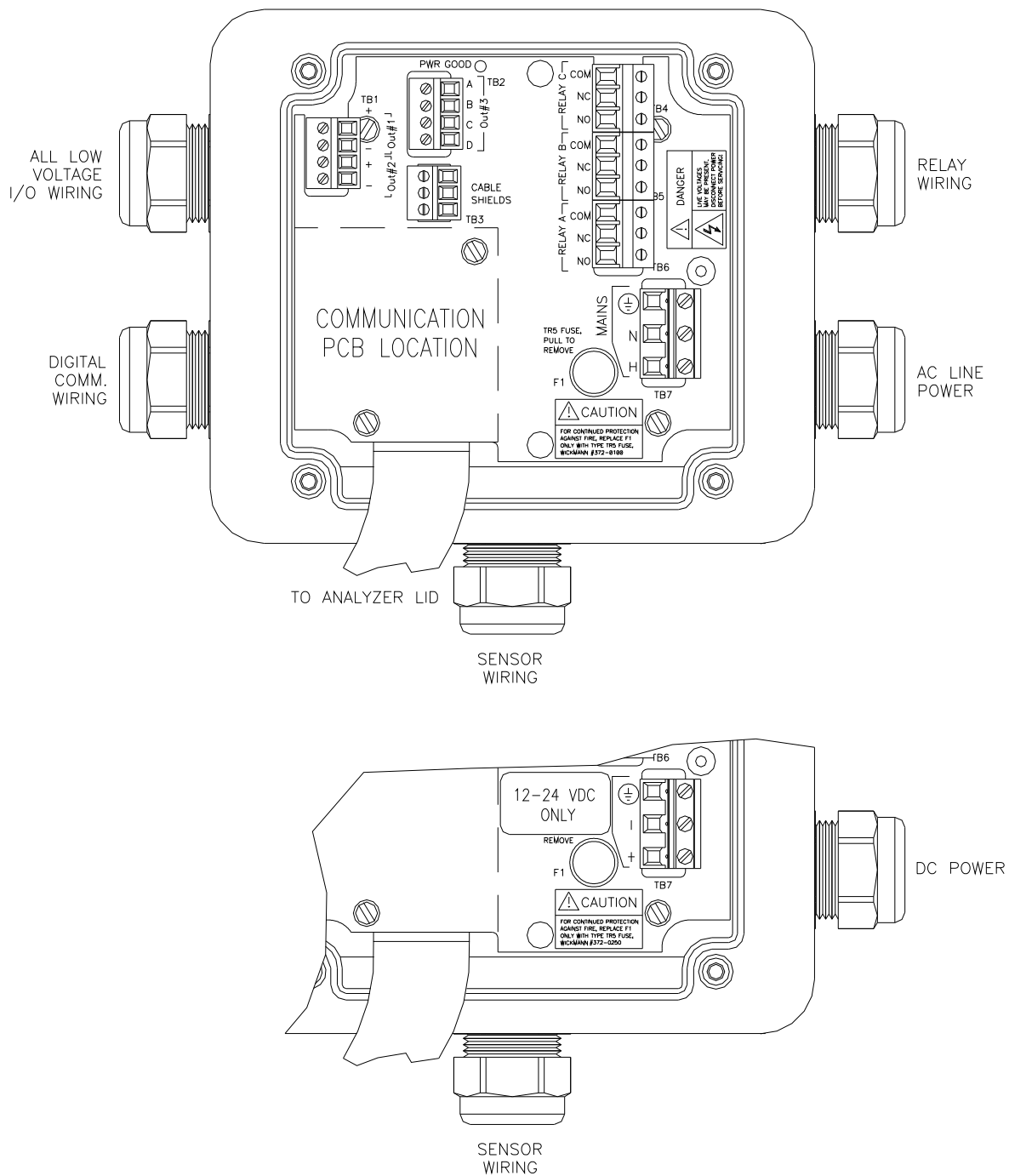

Figure 8 - Q46D Connections

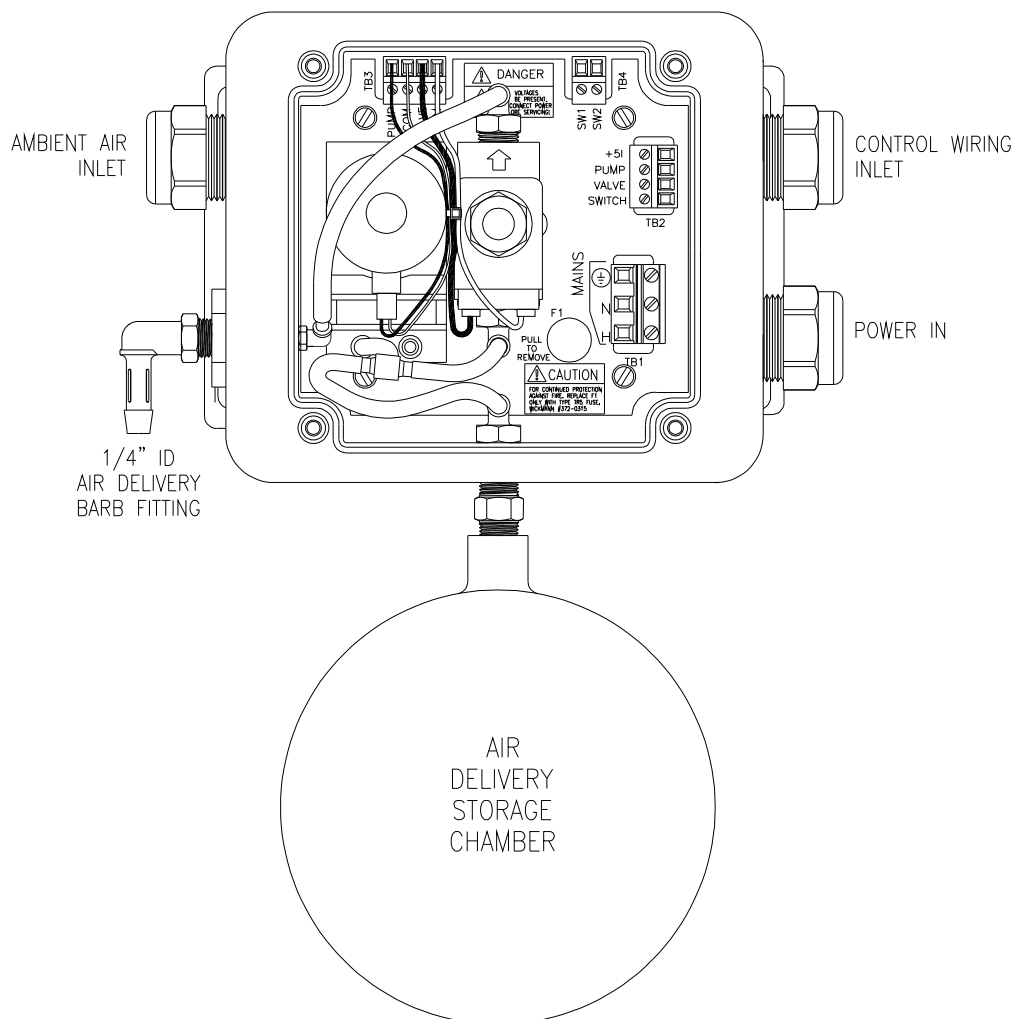

Figure 9 - Q-Blast Connections

3.3 Sensor Connections

Prior to making any sensor connections, the sensor wire and the cleaner air tube must be run up inside the mounting pipe as shown in the previous section, Figure 6 & Figure 7. The sensor cable is connected to the Q46 terminal strip on the front lid of the assembly as shown in Figure 10. The sensor wire color code is marked on the inside label. Route sensor cable away from AC power lines, adjustable frequency drives, motors, or other noisy electrical signal lines. Do not run sensor or signal cables in conduit that contains AC power lines or motor leads.

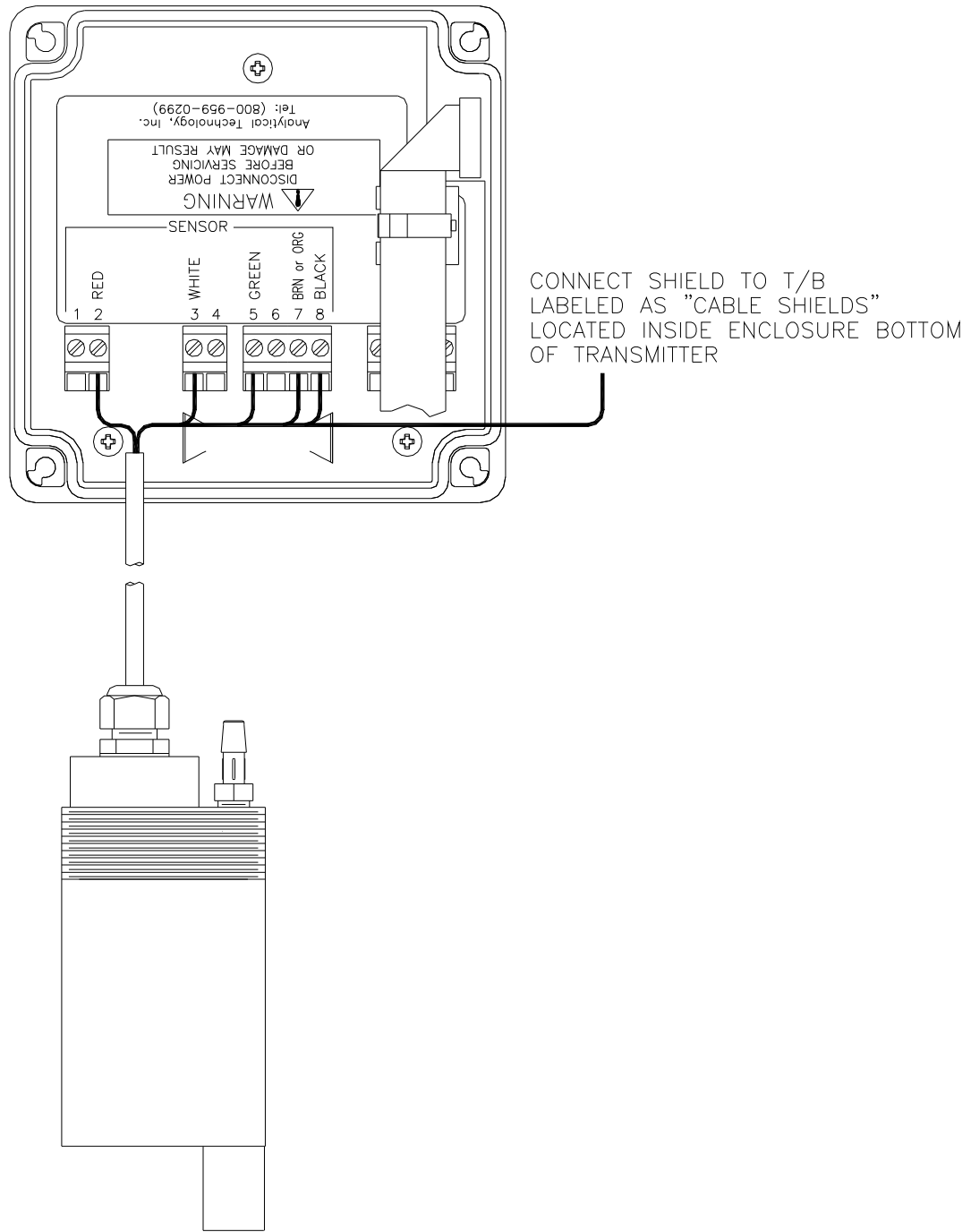

Figure 10 - Sensor Wiring

3.4 Q-Blast to Q46 Connection

Connections inside the Q-Blast enclosure include power and an interconnect cable running to the Q46 monitor. To access the terminal compartment, loosen the 4 screws holding the cover in place and set the cover aside. The screws are captive and should not come completely out of the plastic cover.

As previously mentioned, power for the Q-Blast connects to TB1. An additional 3-conductor cable must be connected between the Q46 analyzer and the Q-Blast cleaner as shown in Figure 11. The sequencing of the compressor and solenoid are controlled by the Q46, with control signals carried by this cable.

Auto-Clean systems must be installed with the Q-Blast assembly no more than 60 ft. from the sensor, and preferably much closer. However, the Q46 analyzer can be installed up to 500 ft. from the cleaner assembly. This allows the display to be located at a convenient spot somewhat remote from the sensor/cleaner location. When a remote cleaner installation is required, interconnect the analyzer and the cleaner unit with 3-conductor, 22 AWG shielded cable as shown in Figure 11 - Electrical Connections¹¹. Do not run the interconnect cable in the same conduit with AC wiring. Note also that a separate junction box is required for the sensor wiring if a remote monitor is to be used. The 3-conductor control wire and the sensor signal wire may be run in the same conduit.

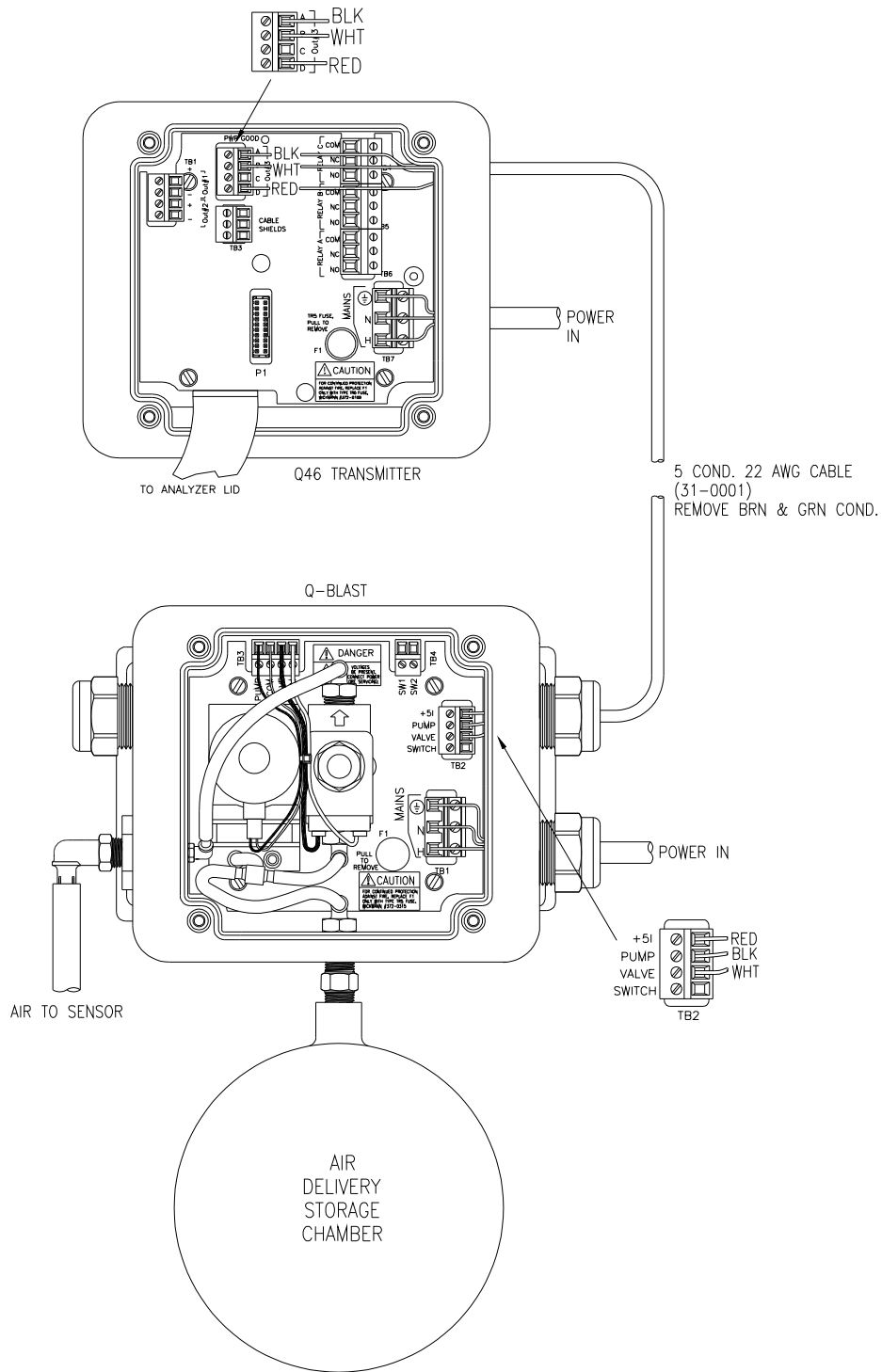

Figure 11 - Electrical Connections

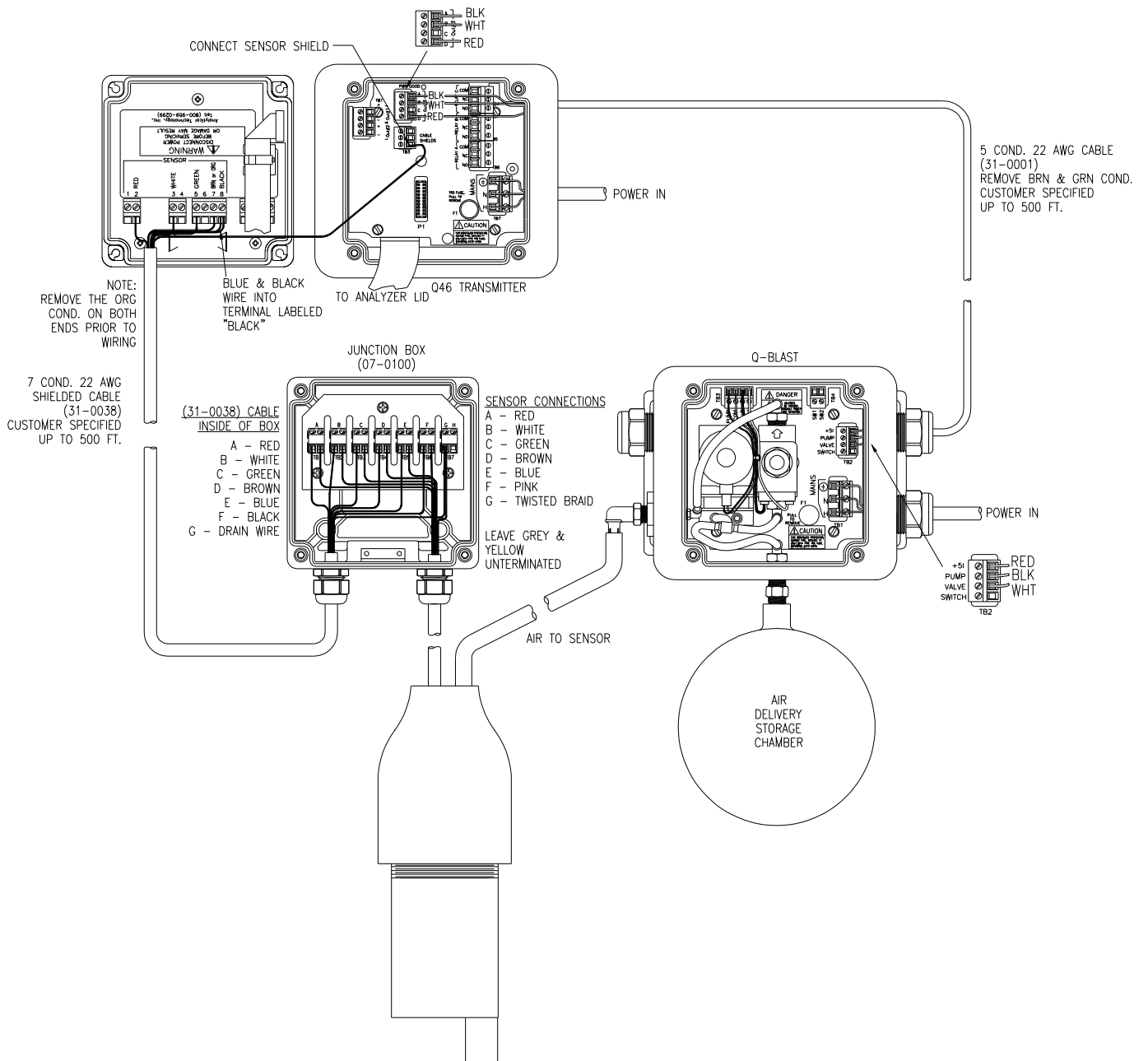

Figure 12 - Q-blast Connections w/Optional J-Box

3.5 Analog Output Connections

Q46 Auto-Clean systems provide two 4-20 mA outputs. Output connections are made to terminal TB1 as shown in Figure 8.

3.6 Relay Connections

Relay wiring is done to terminal blocks inside the Q46 display assembly. This unit actually contains three SPDT relays, and a bank of three low-power relays that is used to control the activation of the sensor automatic cleaning system. Relays A&B are available for use as either control relays or alarm relays. Relay C is configured as a system failure alarm.

To access the terminals for Relays A, B, and C, open the front protective cover of the analyzer. Loosen the 4 corner screws for the display unit and the front will hinge down. A terminal block labeled TB6 is accessible. The terminal block will unplug for wiring convenience, and the circuit board is screened to indicate the NO, NC and C contacts.

The terminal block labeled TB2 is used to connect leads to relays D, E, and F. These relays are prewired for control of the Q-Blast cleaner.

Part 4 - Optical D.O. Sensor

4.1 General

Optical D.O. sensors are supplied complete and ready to use. All that's needed is to make the proper sensor connections as shown in the previous section.

A rubber boot protects the end of the sensor in transit. Leave the protective boot in place until the sensor is to be placed into operation. Removal of the protective boot prior to submergence may expose the sensing element to mechanical damage that is not covered by warranty.

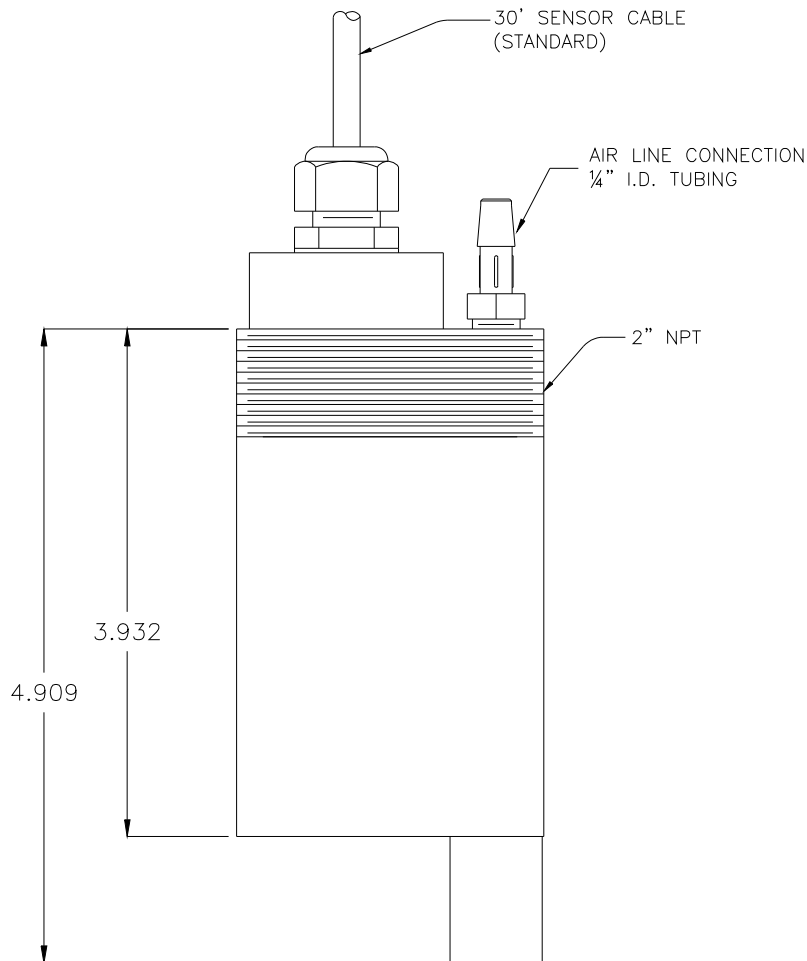

Figure 13 - Submersible D.O. Sensor Assy

4.2 Optical Sensing

Optical D.O. measurement employs a technique called “fluorescence quenching” in order to measure molecular oxygen. The sensor will respond to oxygen either in the air or dissolved in water.

A polymer element at the end of the sensor contains an embedded fluorescent dye. When the element is exposed to a pulse of light from an internal LED, the material in the polymer will fluoresce, or emit light at another wavelength. This light decreases (or is quenched) at a rate proportional to the amount of oxygen in the polymer. The monitor measures the rate at which this quenching occurs and calculates the oxygen concentration based on the measurement.

Optical oxygen sensors provide the ability to measure oxygen in stagnant water, and are not affected by certain kinds of non-biological coatings. However, optical sensors are affected by biologically active coatings and must be kept clean. In activated sludge applications, biological films can have a much lower D.O. concentration on the sensor side of the film than on the bulk solution side. The automatic air cleaning system integrated into the Q46D system will eliminate coating problems by cleaning the sensor on a regular programmed schedule.



Figure 14 - Optical Sensor Element

Part 5 - Operation

5.1 User Interface

The user interface for the Q46 Series instrument consists of a custom display and a membrane keypad. All functions are accessed from this user interface (no internal jumpers, pots, etc.).

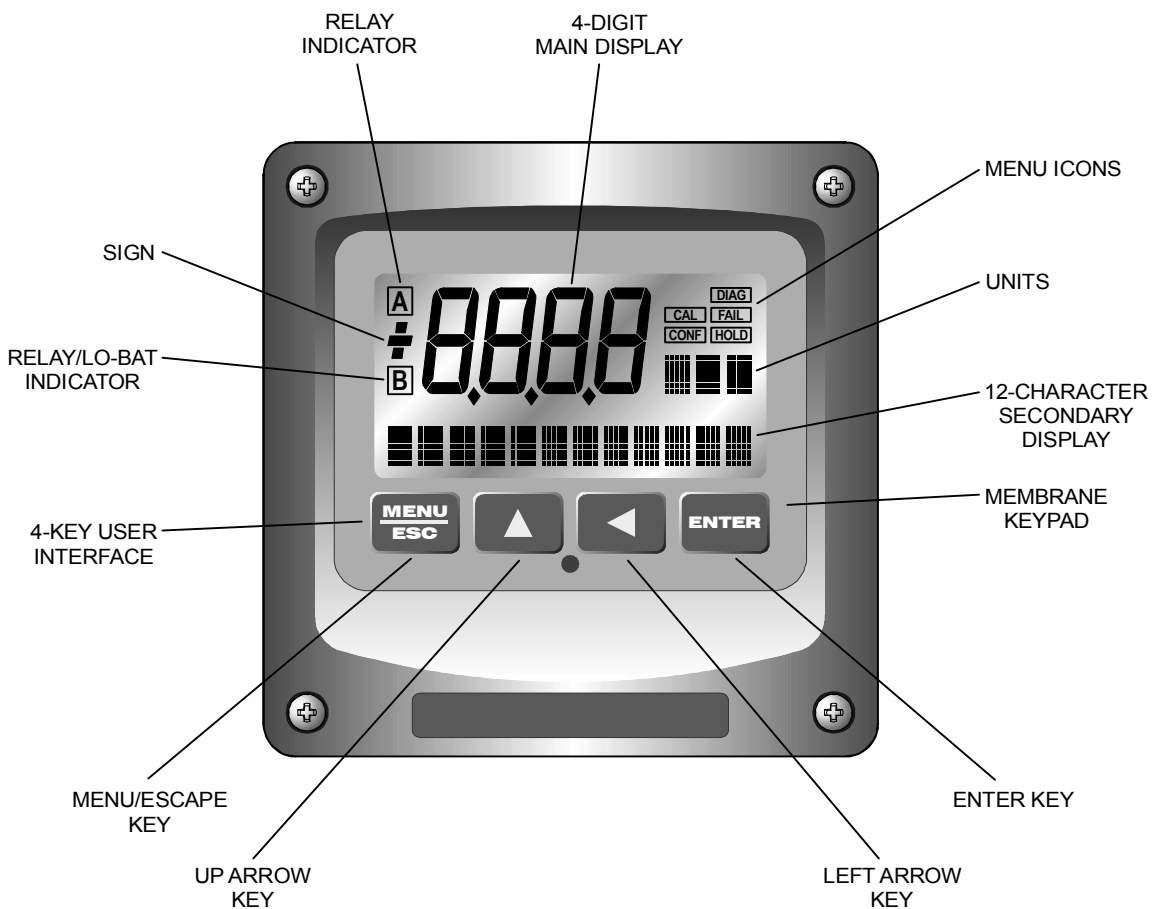

Figure 15 - User Interface

5.11 Keys

All user configurations occur through the use of four membrane keys. These keys are used as follows:

- **MENU/ESC** To scroll through the menu section headers or to escape from anywhere in software. The escape sequence allows the user to back out of any changes in a logical manner. Using the escape key aborts all changes to the current screen and backs the user out one level in the software tree. The manual will refer to this key as either MENU or ESC, depending upon its particular function.
- **UP (arrow)** To scroll through individual list or display items and to change number values.
- **LEFT (arrow)** To move the cursor from right to left during changes to a number value.
- **ENTER** To select a menu section or list item for change and to store any change.

5.12 Display

The large custom display provides clear information for general measurement use and user configuration. There are three main areas of the display: the main parameter display, the secondary message line, and the icon area.

Main Parameter

During normal operation, the main parameter display indicates the present process input with sign and units. This main display may be configured to display any of the main measurements that the system provides. During configuration, this area displays other useful set-up information to the user.



Lower Line

During normal operation, the lower line of the display indicates user-selected secondary measurements that the system is making. This also includes calibration data from the last calibration sequence and the transmitter model number and software version. During configuration, the lower line displays menu items and set-up prompts to the user. Finally, the lower line will display error messages when necessary. For a description of all display messages, refer to Section 10.31.

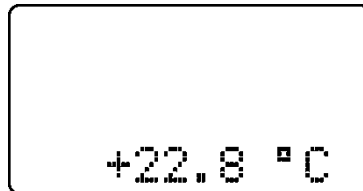
**Icon Area**

The icon area contains display icons that assist the user in set-up and indicate important states of system functions. The CAL, CONFIG, CTRL, and DIAG icons are used to tell the user what branch of the software tree the user is in while scrolling through the menu items. This improves software map navigation dramatically. Upon entry into a menu, the title is displayed (such as CAL), and then the title disappears to make way for the actual menu item. However, the icon stays on.

**HOLD**

The HOLD icon indicates that the current output of the transmitter has been put into output hold. In this case, the output is locked to the last input value measured when the HOLD function was entered. HOLD values are retained even if the unit power is cycled.

FAIL

The FAIL icon indicates that the system diagnostic function has detected a problem that requires immediate attention. This icon is automatically cleared once the problem has been resolved.

Relay Area A/B/C The relay area contains two icons that indicate the state of the system relays. Relay C is normally configured for FAIL indication, so it is only displayed on the lower MEASURE display line.

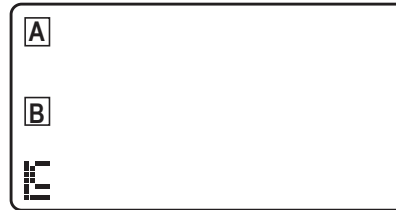

5.2 Software

The software of the Q46D is organized in an easy to follow menu-based system. All user settings are organized under four menu sections: Measure, Calibration [CAL], Configuration [CONFIG], Control [CONTROL] and Diagnostics [DIAG].

Note: The default Measure Menu is display-only and has no menu icon.

5.2.1 Software Navigation

Within the CAL, CONFIG, CONTROL, and DIAG menu sections is a list of selectable items. Once a menu section (such as CONFIG) has been selected with the MENU key, the user can access the item list in this section by pressing either the ENTER key or the UP arrow key. The list items can then be scrolled through using the UP arrow key. Once the last item is reached, the list wraps around and the first list item is shown again. The items in the menu sections are organized such that more frequently used functions are first, while more permanent function settings are later in the list. See Figure 16 for a visual description of the software.

Each list item allows a change to a stored system variable. List items are designed in one of two forms: simple single variable, or multiple variable sequences. In the single variable format, the user can quickly modify one parameter - for example, changing temperature display units from °F to °C. In the multiple variable sequence, variables are changed as the result of some process. For example, the calibration of dissolved oxygen generally requires more than one piece of information to be entered. The majority of the menu items in the software consist of the single variable format type.

Any data that may be changed will be flashing. This flashing indicates user entry mode and is initiated by pressing the ENTER key. The UP arrow key will increase a flashing digit from 0 to 9. The LEFT arrow key moves the flashing digit from right to left. Once the change has been completed, pressing ENTER again stores the variable and stops the flashing. Pressing ESC aborts the change and also exits user entry mode.

The starting (default) screen is always the Measure Menu. The UP arrow key is used to select the desired display. From anywhere in this section the user can press the MENU key to select one of the four Menu Sections.

The UP arrow icon next to all list items on the display is a reminder to scroll through the list using the UP arrow key.

To select a list item for modification, first select the proper menu with the MENU key. Scroll to the list item with the UP arrow key and then press the ENTER key. This tells the system that the user wishes to perform a change on that item. For single item type screens, once the user presses the ENTER key, part or all of the variable will begin to flash, indicating that the user may modify that variable using the arrow keys. However, if the instrument is locked, the transmitter will display the message **Locked!** and will not enter user entry mode. The instrument must be unlocked by entering the proper code value to allow authorized changes to user entered values. Once the variable has been reset, pressing the ENTER key again causes the change to be stored and the flashing to stop. The message **Accepted!** will be displayed if the change is within pre-defined variable limits. If the user decides not to modify the value after it has already been partially changed, pressing the ESC key aborts the modification and returns the entry to its original stored value.

In a menu item which is a multiple variable sequence type, once the ENTER key is pressed there may be several prompts and sequences that are run to complete the modification. The ESC key can always be used to abort the sequence without changing any stored variables.

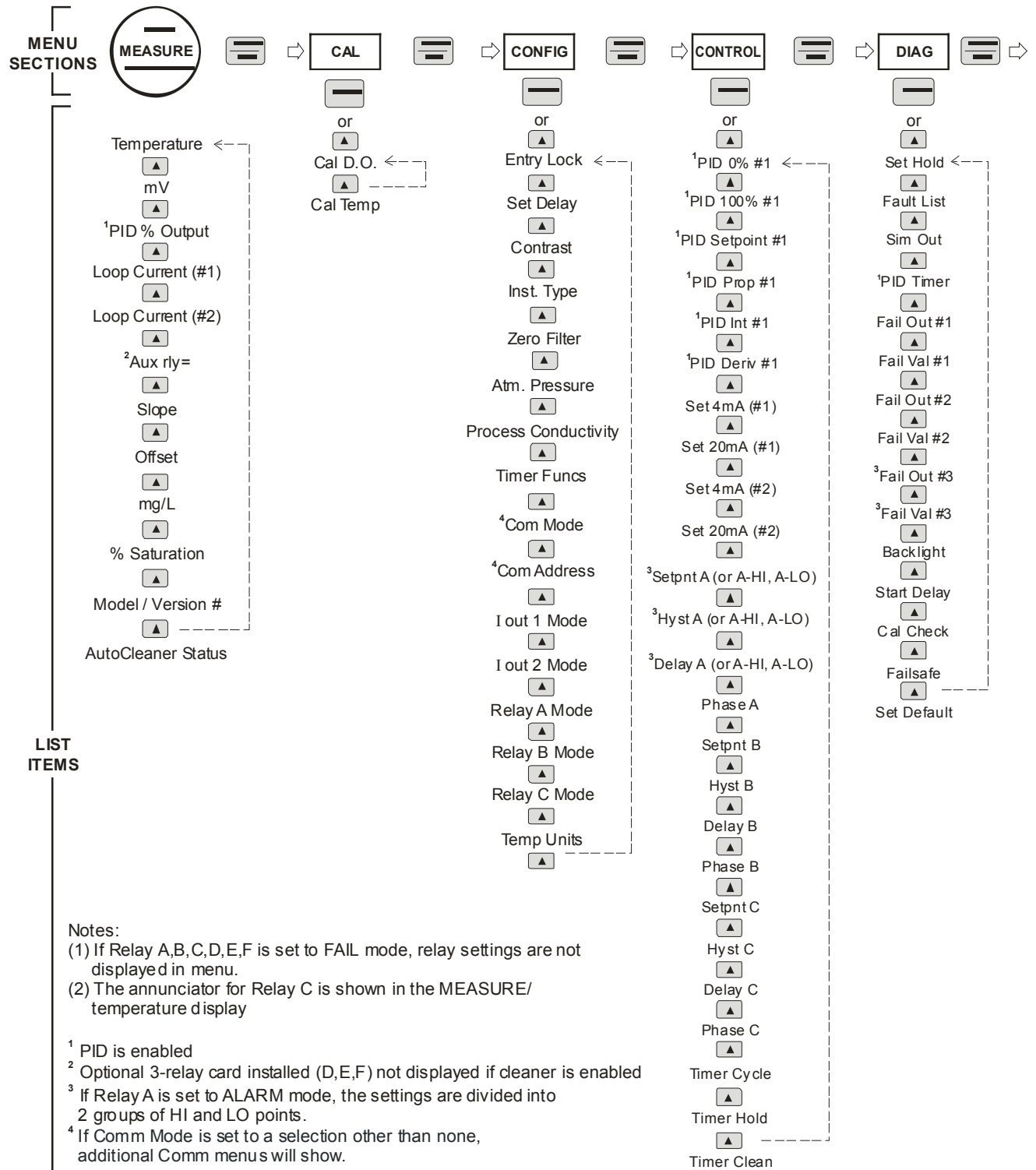

Figure 16 - Software Map

5.22 Measure Menu [MEASURE]

The default menu for the system is the display-only menu MEASURE. This menu is a display-only measurement menu, and has no changeable list items. When left alone, the instrument will automatically return to this menu after approximately 30 minutes. While in the default menu, the UP arrow allows the user to scroll through the secondary variables on the lower line of the display. A brief description of the fields in the basic transmitter version is as follows:

TRANSMITTER MEAS SCREENS:

| | |
|-------------------------|--|
| 25.7° | Temperature display. Can be displayed in °C or °F, depending on user selection. A small “m” on the left side of the screen indicates the transmitter has automatically jumped to a manual 25C setting due to a failure with the temperature signal input. |
| 320 mV | Raw sensor signal. Useful for diagnosing problems. |
| 100% 20.00 mA | PID Status screen (if enabled.) Shows the present controller output level on left, and actual transmitter current on the right. The controller can be placed in manual while viewing this screen by pressing and holding the ENTER key for 5 seconds until a small flashing “m” appears on the screen. At that point the controller output can be adjusted up or down using the UP and LEFT arrow keys. To return to automatic operation, press and hold the ENTER key for 5 seconds and the “M” will disappear. |
| #1 4.00 mA | Analyzer output current # 1. |
| #2 12.00 mA | Analyzer output current # 2. |
| Aux relay= D,E,F | Auxiliary relay annunciators (if option included.) |
| Slope = 100% | Sensor output response vs. ideal calibration. This value updates after each calibration. As the sensor ages, the slope reading will decay indicating sensor aging. Useful for resolving sensor problems. |

| | |
|------------------------|--|
| Offset = 0.0 mV | Sensor output signal at a zero ppm input. This value updates after a zero-calibration has been performed. Useful for resolving sensor problems. |
| 0.00 PPM | D.O. Reading in PPM (or mg/L if selected under Instr Type) |
| % Saturation | The most common display of D.O. in water is either PPM or mg/L units. However, the same PPM value at different water temperatures can represent quite different concentrations of oxygen in terms of the percent of saturation. This display simply indicates the % of oxygen saturation represented by the current PPM or mg/L display. |
| Q46D v4.02 | Transmitter software version number. |
| Tcyc 24.0hr | Automatic sensor cleaning frequency. |

Note: A display test (all segments ON) can be actuated by pressing and holding the ENTER key while viewing the model/version number on the lower line of the display.

The MEASURE screens are intended to be used as a very quick means of looking up critical values during operation or troubleshooting.

5.23 Calibration Menu [CAL]

The calibration menu contains items for frequent calibration of user parameters. There are two items in this list: Cal D.O., Cal Temp.

Cal D.O. The oxygen calibration function allows the user to adjust the transmitter span reading to match a reference solution, or to set the sensor zero point. See Part 6 - Calibration for more details.

Cal Temp The temperature calibration function allows the user to adjust the offset of the temperature response by a small factor of ± 5 °C. The temperature input is factory calibrated to very high accuracy. However, long cable lengths and junction boxes may degrade the accuracy of the temperature measurement in some extreme situations. Therefore, this feature is provided as an adjustment. See Part 6 - Calibration for more details.

5.24 Configuration Menu [CONFIG]

The Configuration Menu contains all of the general user settings:

- Entry Lock** This function allows the user to lock out unauthorized tampering with instrument settings. All settings may be viewed while the instrument is locked, but they cannot be modified. The Entry Lock feature is a toggle-type setting; that is, entering the correct code will lock the transmitter and entering the correct code again will unlock it. The code is preset at a fixed value. Press ENTER to initiate user entry mode and the first digit will flash. Use arrow keys to modify value. **See Spare Parts List at the end of this manual for the Q46D lock/unlock code.** Press ENTER to toggle lock setting once code is correct. Incorrect codes do not change state of lock condition.
- Set Delay** The delay function sets the amount of damping on the instrument. This function allows the user to apply a first order time delay function to the oxygen measurements being made. Both the display and the output value are affected by the degree of damping. Functions such as calibration are not affected by this parameter. The calibration routines contain their own filtering and stability monitoring functions to minimize the calibration timing. Press ENTER to initiate user entry mode, and the value will flash. Use the arrow keys to modify value; range is 0.1 to 9.9 minutes. Press ENTER to store the new value.
- Contrast** This function sets the contrast level for the display. The custom display is designed with a wide temperature range and contains an LED back light so that the display is can be seen in the dark.
- Press ENTER to initiate user entry mode, and the value will flash. Use arrow keys to modify the value; range is 0 to 8 (0 being lightest). Press ENTER to update and store the new value.
- Instr Type** This function allows the user to change the type of measurement to be displayed in the primary display area. The user may select “**1 PPM**”, “**2 mg/L**”, or “**3 %Sat**”. There is not a great deal of difference between type 1 and 2 settings as PPM and mg/L measurement units are pretty close to the same.

Programming for type 3 percent saturation changes the measured parameter to read a dissolved oxygen value that represents the percent of oxygen saturation at a given temperature. When this unit of measurement is selected, the main analog output and all alarm and control functions will relate to this measurement. While a PPM measurement is displayed on the lower line, it is no longer the primary variable being measured by the system. Press ENTER to initiate user entry mode, and the selected value will flash. Use the UP arrow key to modify the desired display value. Press ENTER to store the new value.

Zero Filter

The Q46D allows the user to program a value near zero below which the monitor will read zero. Because sensors rarely have a perfect zero stability, this zero filter eliminates occasional displays of numbers that are not meaningful. For instance, setting a zero filter at 0.03 PPM D.O. will cause any measured values of 0.01 or 0.02 PPM to be displayed as 0.00 PPM.

AtmPres

The Q46D instrument utilizes the atmospheric pressure value as an input for the calculation of a theoretical ppm value during a saturation calibration. The input default units are inHg (inches Mercury) since these units are easy to obtain from most local weather services or from the general chart located in Figure 22 of this manual. This value is only required to be entered during initial installation – it does not need to be modified at every calibration. Press ENTER to initiate user entry mode and the entire value will flash. Use the arrow keys to modify the value; range is 20.00 to 31.50 inHg.

A reference table is provided in Section 10 to convert to inHg from several other common air pressure units. Press ENTER to store the new value.

Proc Cond

The Q46D instrument also utilizes the process conductivity value as an input for the calculation of a theoretical ppm value during a saturation calibration. This value is only required to be entered during initial installation - it does not need to be modified at every calibration. Press ENTER to initiate user entry mode and the value will flash. Use the arrow keys to modify the value; range is 0.00 to 76.00 mS/cm. Press ENTER to store the new value.

Note: If the user will not be changing solution conductivity dramatically during the calibration process, leave a default setting of 00.50 mS/cm. For ultrapure water applications, set this value to 0.00. For sea water applications, set this value to 53.00.

Timer Funcs

Enables the Q-Blast Logic on Relays D, E, and F. When enabled, these auxiliary relays control the remote Q-Blast enclosure. The Q-Blast enclosure provides automatic sensor cleaning using a highly effective air-blast system that is self contained in the AC enclosure. When enabled, the D, E and F relay settings are not displayed in the CONFIG or CNTRL menus.

Com Mode

Sets digital communication mode of analyzer. Optional digital communication card must be plugged into the power supply slot for this function to work. Press ENTER to initiate user entry mode, and the entire value will flash. Use the UP arrow key to modify the desired value; selections include 1- None, 2- P-DP for Profibus DP, 3 – Modbus, 4 – Ethernet IP. Press ENTER to store the new value.

Com Address

Sets bus address for digital communication mode of analyzer. Optional digital communication card must be plugged into the power supply slot for this function to work.

Press ENTER to initiate user entry mode, and the entire value will flash. Use the UP arrow key to modify the desired value. Range is 1-125. Press ENTER to store the new value.

lout#1 Mode

This function sets analog output #1 to either track PPM or mg/L oxygen (default), % Saturation, or enables the PID controller to operate on the oxygen input in either PPM, mg/L, or % Saturation. Press ENTER to initiate user entry mode, and the entire value will flash. Use the UP arrow key to modify the desired value; selections include 1- for oxygen tracking or 2-PID for oxygen PID control. Press ENTER to store the new value.

***Iout#2 Mode** This function sets analog output #2 for either temperature (default) or oxygen. Press ENTER to initiate user entry mode, and the entire value will flash. Use the UP arrow key to modify the desired value; selections include 1-C/F for temperature, or 2-ppm for oxygen, or 3-% Saturation. Press ENTER to store the new value.

***Rly A Mode** Relay A can be used in three different ways: as a setpoint control, as a fail alarm, or as a HI-LO alarm band. The three settings for Rly A Mode are **CON**, **FAIL** and **AL**.

The **CON** setting enables normal control operation for Relay A, with settings for setpoint, hysteresis, delay and phasing appearing in the CONFIG menu automatically. See Figure 18 for further details.

The **FAIL** setting enables the fail alarm mode for Relay A. Relay A will then trip on any condition that causes the FAIL icon to be displayed on the LCD. Using this mode allows the User to send alarm indications to other remote devices.

The **AL** setting allows two setpoints to be selected for the same relay, producing a HI-LO alarm band. In this mode, Relay A will trip inside or outside of the band, depending upon the Phase selected. See Figure 18 for further details.

***Relay B Mode** The settings for Relay B Mode are identical to the corresponding modes on Relay A.

Relay C Mode Relay C can be used in two ways: as a setpoint control, or as an alarm. The two settings for Relay C Mode are **CON** and **FAIL**.

The **CON** setting enables normal setpoint operation for Relay B/C. Relay B/C then operates identically to Relay A, with settings for setpoint, hysteresis, delay and phasing appearing in the CONFIG menu automatically. See Figure 17 for details.

The **FAIL** setting enables the fail alarm mode for Relay B/C. Relay B/C will then trip on any condition that causes the FAIL icon to be displayed on the LCD. Note that the Relay C indicator shows up only on the lower screen of the display next to the temperature reading. This is because the default setting for relay C is the **FAIL** setting. Using this mode

allows the User to send alarm indications to other remote devices. See Figure 18 for details.

Temp Units

This function sets the display units for temperature measurement. Press ENTER to initiate user entry mode, and the entire value will flash. Use the UP arrow key to modify the desired display value. The choices are °F and °C. Press ENTER to store the new value.

5.25 Control Menu [CONTROL]

The Control Menu contains all of the output control user settings. Note that PID menu items will not appear unless output 1 is configured for PID mode in the CONFIG menu.

Set PID 0%

Set PID 100%

[lout1=PID]

If the PID is enabled, this function sets the minimum and maximum controller end points. Unlike the standard 4-20 mA output, the controller does not “scale” output values across the endpoints. Rather, the endpoints determine where the controller would normally force minimum or maximum output in an attempt to recover the setpoint (even though the controller can achieve 0% or 100% anywhere within the range.)

If the 0% point is lower than the 100% point, then the controller action will be “reverse” acting. That is, the output of the controller will increase if the measured value is less than the setpoint, and the output will decrease if the measured value is larger than the setpoint. Flipping the stored values in these points will reverse the action of the controller to “direct” mode.

The entry value is limited to a value within the range specified in “Set Range”, and the 0% and the 100% point must be separated by at least 1% of this range. Use the LEFT arrow key to select the first digit to be modified. Then use the UP and LEFT arrow keys to select the desired numerical value. Press ENTER to store the new value.

PID Setpnt

[lout1=PID]

The measured value which the controller is attempting to maintain by adjusting output value. It is the nature of the PID controller that it never actually gets to the exact value and stops. The controller is continually making smaller and

smaller adjustments as the measured value gets near the setpoint.

PID Prop
[lout1=PID]

Proportional gain factor. The proportional gain value is a multiplier on the controller error (difference between measured value and setpoint value.) Increasing this value will make the controller more responsive.

PID Int
[lout1=PID]

Integral is the number of “repeats-per-minute” of the action of the controller. It is the number of times per minute that the controller acts on the input error. At a setting of 2.0 rpm, there are two repeats every minute. If the integral is set to zero, a fixed offset value is added to the controller (manual reset.) Increasing this value will make the controller more responsive.

PID Deriv
[lout1=PID]

Derivative is a second order implementation of Integral, used to suppress “second-order” effects from process variables. These variables may include items like pumps or mixers that may have minor impacts on the measured value. The derivative factor is rarely used in water treatment process, and therefore, it is best in most cases to leave it at the default value. Increasing this value will make the controller more responsive.

Set 4 mA
Set 20 mA
[lout1=D.O.]

These functions are used to modify the first 4-20 mA current output setpoints for the transmitter. The units displayed depend on the selection made in the CONFIG menu for lout #1 Mode.

The value stored for the 4 mA point may be higher or lower than the value stored for the 20 mA point. The entry values are limited to values within the range specified in “Set Range”, and the 4 mA and the 20 mA point must be separated by at least 1% of this range. Use the LEFT arrow key to select the first digit to be modified. Then use the UP and LEFT arrow keys to select the desired numerical value. Press ENTER to store the new value.

Set 4 mA #2**Set 20 mA #2**

[temp/D.O.]

These functions are used to modify the second 4-20 mA current output setpoints for the transmitter. The output may be set to track temperature (default), PPM oxygen, or % Saturation. The values stored for the 4 mA point may be higher or lower than the value stored for the 20 mA point.

The entry value is limited to a value between 0 and 50 °C if it is set for temperature, within the range specified in "Set Range" if the output is set to track oxygen. The 4 mA and the 20 mA point must be at least 2 units away from each other. Press ENTER to initiate user entry mode, and the value will flash. Use arrow keys to modify value. Press ENTER to store the new value.

NOTE: If the temperature units are changed between °C and °F (see Temp Units in this section), the default settings for this output will be stored (present data is not converted.)

***A Setpoint**

This function establishes the oxygen trip point for relay A. The entry value is limited to a value within the range specified in "Set Range". Use the LEFT arrow key to select the first digit to be modified. Then use the UP and LEFT arrow keys to select the desired numerical value. Press ENTER to store the new value.

***A Hysteresis**

This function establishes the hysteresis, or "deadband", for Relay A. Hysteresis is most often used to control relay chattering; however, it may also be used in control schemes to separate the ON/OFF trip points of the relay. Press ENTER to initiate user entry mode, and the value will flash. Use the arrow keys to modify value. Press ENTER to store the new value.

***A Delay**

This function places an additional amount of time delay on the trip point for relay A. This delay is in addition to the main delay setting for the controller. The entry value is limited to a value between 0 and 999 seconds. Press ENTER to initiate user entry mode, and the value will flash. Use arrow keys to modify value; range is 0 to 999 seconds. Press ENTER to store the new value.

***A Phasing**

This function establishes the direction of the relay trip. When phase is HI, the relay operates in a direct mode.

Therefore, the relay energizes and the LCD indicator illuminates when the oxygen value **exceeds** the setpoint. When the phase is LO, the relay energizes and the LCD indicator illuminates when the oxygen level drops **below** the setpoint. The failsafe setting does have an impact on this logic. The description here assumes the failsafe setting is OFF. Press ENTER to initiate user entry mode, and the entire value will flash. Use the UP arrow key to modify the desired value; selections include **HI** for direct operation or **LO** for reverse operation. Press ENTER to store the new value. See Figure 17 below for a visual description of a typical control relay application.

When value rises to ≥ 1.000 ppm, relay closes.

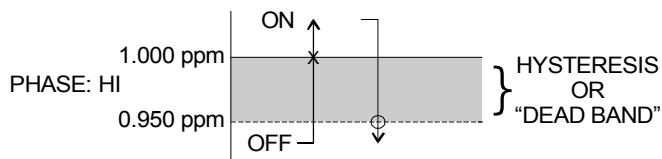

When value rises to ≥ 1.050 ppm, relay opens.

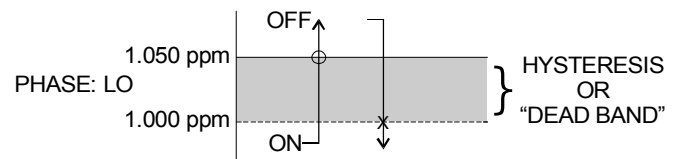

When value falls to ≤ 0.950 ppm, relay opens.

When value falls to ≤ 1.000 ppm, relay closes.

Settings:

Setpoint: 1.000 ppm
 Hyst: 0.050
 Delay: 000
 Failsafe: OFF

Figure 17 - Control Relay, Hysteresis & Phase Options

*Setpnt A-HI
 *Hyst A-HI
 *Delay A-HI
 *Setpnt A-LO
 *Hyst A-LO
 *Delay A-LO

If Relay A Mode is set to Alarm Mode, **AL**, then the following settings will appear in the Config Menu list automatically. In this mode, two setpoints can be selected on the same relay, to create an alarm band. Phase HI selection causes the relay to energize outside of the band, and Phase LO causes the relay to energize inside of the band. This feature enables one relay to be used as a control relay while the other is used as a HI-LO Alarm relay at the same time. Setpoint A-LO must be set lower than Setpoint A-HI. When AL mode is first selected, Setpoint A-LO is defaulted to 0.

Figure 18 is a visual description of a typical alarm relay application.

When value rises to ≥ 1.000 ppm,
 relay closes, until value falls back to \leq
 0.950 ppm.

When value falls to ≤ 1.000 ppm,
 relay closes, until rises back to \geq
 1.050 ppm.

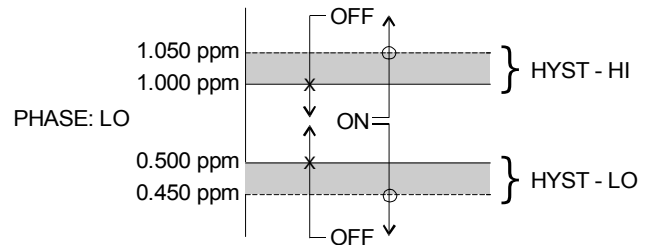
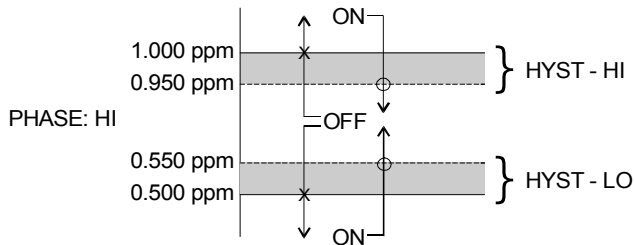

When value falls to ≤ 0.500 ppm,
 relay closes, until rises back to \geq
 0.550 ppm.

When value rises to ≥ 0.500 ppm,
 relay closes, until value falls back to \leq
 0.450 ppm.

Settings:

| | | | |
|----------|-----------------|----------|----------------|
| Setpoint | A-HI: 1.000 ppm | Setpoint | A-LO: .500 ppm |
| Hyst | A-HI: 0.050 | Hyst | A-LO: 0.050 |
| Delay | A-HI: 000 | Delay | A-LO: 000 |

Figure 18 - Alarm Relay Example

- *B Setpoint**
- *B Hysteresis**
- *B Delay**
- *B Phasing**

If Relay B Mode is set to **CON**, then Relay B will function identically to Relay A. Relay B settings appear in the CONFIG menu list automatically.

- C Setpoint**
- C Hysteresis**
- C Delay**
- C Phasing**

If Relay C Mode is set to **CON** (see **Relay C Mode**), then Relay C will function identically to Relay A. Relay C settings appear in the CONFIG menu list automatically.

***Timer CYCLE**
***Timer CLEAN**
***Timer HOLD**

When Timer Funcs is set to ON in the Config Menu, three additional menu items appear in the Control Menu. These are Timer Cycle, Timer Clean, and Timer Hold.

The timer CYCLE setting controls the frequency of the cleaning function. The frequency should not be set to more than once every 3 hours and can be adjusted up to 999 hours. A good starting frequency is 24 hours.

The timer CLEAN setting allows adjustment of the number of cleaning pulses that occur during each cycle. The default is 3 pulses, which requires about 2 minutes to complete. This value should not be increased to more than 6 pulses.

The timer HOLD setting controls the amount of time the analog output is held at the end of the cleaning cycle. This hold time allows the outputs to stabilize back to normal readings. The default value is 1 minute which is normally sufficient time for the measurement to stabilize after cleaning.

To change the values for Timer CYCLE, CLEAN, and HOLD, press ENTER to initiate user entry mode, and entire value will flash. Use the UP arrow key to modify the desired value. Selections for each variable are: CLEAN 1-10 minutes, CYCLE 1-999 hours, HOLD 0-999 minutes. Press ENTER to store the new value.

Example: If the timer-CYCLE setting is 24 hours, the timer CLEAN setting is 3 pulses, and the timer-HOLD setting is 1 minutes, the following sequence will occur: At the instant the timer is enabled, the time period begins. Once the 24-hour CYCLE period ends, the outputs will be put in hold and relay D and relay E will cycle to run the compressor in the Q-Blast module and to energize the solenoid for delivery of the air pulses. After the completion of 3 air-blast pulses, the cycle will end. The hold will stay locked in for an additional 1 minute (HOLD time), retaining the original output signals. Once the minute expires, the outputs will be released back to the normal monitoring state. Then, the entire cycle will repeat – approximately once per day.

Note: The sensor cleaning timer is not based on a “real-time” clock circuit. Therefore, the time accuracy is only within about 10 minutes per day.

Note: A cleaning cycle can be manually started by pressing and holding the ENTER key for a few seconds while viewing the timer status screen in the MEAS menu. The timer must be in the “Tcyc” state to allow a manual start. After this forced cycle, the system will return to normal.

5.26 Diagnostics Menu [DIAG]

The diagnostics menu contains all of the user settings that are specific to the system diagnostic functions, as well as functions that aid in troubleshooting application problems.

Set Hold

The Set Hold function locks the current loop output values on the present process value and holds relays in current status. This function can be used prior to calibration, or when removing the sensor from the process, to hold the output in a known state. Once HOLD is released, the outputs return to their normal state of following the process input. The transfer out of HOLD is bumpless on the both analog outputs - that is, the transfer occurs in a smooth manner rather than as an abrupt change. An icon on the display indicates the HOLD state, and the HOLD state is retained even if power is cycled. Press ENTER to initiate user entry mode, and entire value will flash. Use the UP arrow key to modify the desired value, selections are **ON** for engaging the HOLD function, and **OFF** to disengage the function. Press ENTER to store the new value.

The Set Hold function can also hold at an output value specified by the user. To customize the hold value, first turn the HOLD function on. Press the ESC key to go to the DIAG Menu and scroll to Sim Output using the UP arrow key. Press ENTER. Follow the instructions under Sim Output (see following page).

Fault List

The Fault List screen is a read-only screen that allows the user to display the cause of the highest priority failure. The screen indicates the number of faults present in the system and a message detailing the highest priority fault present. Note that some faults can result in multiple displayed failures

due to the high number of internal tests occurring. As faults are corrected, they are immediately cleared.

Faults are not stored; therefore, they are immediately removed if power is cycled. If the problem causing the faults still exists, however, faults will be displayed again after power is re-applied and a period of time elapses during which the diagnostic system re-detects them. The exception to this rule is the calibration failure. When a calibration fails, no corrupt data is stored. Therefore, the system continues to function normally on the data that was present before the calibration was attempted.

After 30 minutes or if power to the transmitter is cycled, the failure for calibration will be cleared until calibration is attempted again. If the problem still exists, the calibration failure will re-occur. Press ENTER to initiate view of the highest priority failure. The display will automatically return to normal after a few seconds.

PID Timer

This function sets a timer to monitor the amount of time the PID controller remains at 0% or 100%. This function only appears if the PID controller is enabled. If the timer is set to 0000, the feature is effectively disabled. If the timer value is set to any number other zero, a FAIL condition will occur if the PID controller remains at 0% or 100% for the timer value. If one of the relays is set to FAIL mode, this failure condition can be signaled by a changing relay contact.

Press ENTER to initiate user entry mode, and the entire value will flash. Use the UP arrow key to modify desired value; range of value is 0-9999 seconds. Press ENTER to store the new value.

Sim Out

The Sim Out function allows the user to simulate the oxygen level of the instrument in the user selected display range. The user enters a ppm value directly onto the screen, and the output responds as if it were actually receiving the signal from the sensor. This allows the user to check the function of attached monitoring equipment during set-up or troubleshooting. Escaping this screen returns the unit to normal operation. Press ENTER to initiate the user entry mode, and the right-most digit of the value will flash. Use arrow keys to modify desired value.

The starting display value will be the last read value of the input. The output will be under control of the SIM screen until the ESC key is pressed.

Note: If the HOLD function is engaged before the Sim Output function is engaged, the simulated output will remain the same even when the ESC key is pressed. Disengage the HOLD function to return to normal output.

Fail Out #1

This function enables the user to define a specified value that the main current output will go to under fault conditions. When enabled to **ON**, the output may be forced to the current value set in **Fail Val** (next item.) With the Fail Out setting of ON, and a Fail Val setting of 6.5 mA, any alarm condition will cause the current loop output to drop outside the normal operating range to exactly 6.5 mA, indicating a system failure that requires attention.

Press ENTER to initiate user entry mode, and the entire value will flash. Use the UP arrow key to modify desired value; selections are **ON**, **OFF**. Press ENTER to store the new value.

Fail Val #1

Sets the output failure value for lout#1. When **Fail Out** above is set to **ON**, this function sets value of the current loop under a FAIL condition. When the Relay Option Board is installed, the display will read **Fail Out #1**. The output may be forced to any current value between 4-20 mA.

Press ENTER to initiate user entry mode, and the entire value will flash. Use the UP arrow key to modify desired value; selections are between **4mA**, and **20mA**. Press ENTER to store the new value.

Fail Out #2

This function sets the fail-mode of current loop output #2 under a FAIL condition. The settings and operation are identical to Fail Out for output #1.

Fail Val #2

This function sets the value of current loop output #2 under a FAIL condition. The settings and operation are identical to Fail Out for output #1.

Backlight

This function has three options. **ON** – On all the time, **OFF** – Off all the time, **AL** – Alarm (Default). This function flashes the backlight on and off whenever the Fail icon is displayed.

Start Delay

This function is designed to minimize control or alarm issues arising from temporary power loss. When power goes down, the monitor records the analog output values and the status of relays and PID functions. When power is restored, the analog values and relays will be held at the pre-power loss values for a defined period of time. This “start delay” may be programmed for periods from 0-9.9 minutes. This function is set to 0.0 minutes by default and must be activated by the user if desired by setting a positive time value.

Cal Check

This feature can be enabled to run at the completion of every Q-Blast cycle to check sensor operation. When enabled, this feature uses the Q-Blast enclosure to blast air past the sensor face, while submerged, for a fixed amount of time. During that time, the sensor saturation reading is checked to see if it is within certain limits (75%-125%). If the reading comes back within range, the Q-Blast cycle completes as normal. If the reading is out of range, a FAIL diagnostic flag will be tripped and the FAIL relay (if set) can be used to indicate a failure. NOTE – This feature may not work under all circumstances, and must be evaluated for your specific application. Very high flow fluid rates may displace the forced air stream, and a good saturation reading may be difficult to obtain.

***Failsafe**

This function allows the user to set the optional system relays to a failsafe condition. In a failsafe condition, the relay logic is reversed so that the relay is electrically energized in a normal operating state. By doing this, the relay will not only change state when, for example, an oxygen limit is exceeded, but also when power is lost to the controller.

When failsafe is selected to be ON, the normally-open contacts of the relay will be closed during normal operation. In an attempt to make this configuration less confusing, the LCD icon logic is reversed with this setting, and the icon is OFF under this normal condition. Therefore, when the trip condition occurs, the closed N.O. contacts will be opened (relay de-energized), and the LCD icon will illuminate. In addition, a power fail would also cause the same contacts to open.

Set Default

The Set Default function allows the user to return the instrument back to factory default data for all user settings or for just the calibration default. It is intended to be used as a last resort troubleshooting procedure. All user settings or the calibration settings are returned to the original factory values. Hidden factory calibration data remains unchanged. Press ENTER to initiate user entry mode and select either **CAL** or **ALL** with the UP arrow key. The default CAL routine will reset the zero offset to 0.0 nA and reset the slope to 100%. The default ALL routine will reset all program variables to factory default and should be used with care since it will change any user settings that were programmed in the field..

Part 6 - Calibration

6.1 General

The instrument must be calibrated periodically to maintain a high degree of measurement accuracy. A complete calibration will include zeroing and spanning the sensor. **It is generally unnecessary to set the zero at every calibration**, but it should be done during the initial installation.

The output of the optical dissolved oxygen sensor will degrade very slowly over the lifetime of the optical element, which is normally 3-5 years. To account for this degradation, the Q45D system should be re-calibrated about every 6 months. The frequency of calibration must be determined by the application. High temperature applications or applications involving other extreme operating conditions may require more frequent calibration than those operating at more ambient levels. It is important for the user to establish a periodic calibration schedule for a particular application. Before calibrating with a new sensor for the first time, or whenever a sensor has been left unpowered for 10 days or more, first connect the sensor to the transmitter and allow the system to operate for at least 2 hours to allow for sensor stabilization and hydration of the optical element. Once the sensor has been properly conditioned, the user must select the proper operating parameters, including atmospheric pressure and solution conductivity.

The system provides three methods of D.O. calibration: 1-Point (sample), % Saturation (air cal), and Zero. These three methods are significantly different.

6.2 D.O. Span Cal (1-spl)

The 1-Point (sample or comparison) method is intended to be primarily used as an on-line calibration; however, the sensor can be removed, cleaned and then calibrated in a bucket of clean water if necessary. During calibration, the system will display the current ppm reading and the user can manually enter a reference value from a lab sample or comparative reference instrument. In the Q46D system, the 1-Point calibration adjusts the slope of the sensor output response.

1. Determine whether the calibration will be done on-line or with the sensor removed and placed into a bucket of clean water. If the sensor is removed from the application, rinse and clean if necessary.
2. If the sensor has been removed and placed into a bucket of water, allow sensor to temperature equilibrate with the solution as much as possible. With the sensor coming from an application which differs greatly in temperature, the user may have to wait as much as 20 minutes. If the sensor is on-line, the user may want to set the output HOLD feature prior to calibration to lock out any output fluctuations.
3. Scroll to the CAL menu section using the MENU key and press ENTER or the UP arrow key. **Cal DO** will then be displayed.
4. Press the ENTER key. The screen will display a flashing **1-spl** for 1-point, a **%-sat** for Saturation air calibration, or a **3-zer** for zero calibration. Using the UP arrow key, set for a 1-spl calibration and press ENTER.
5. The system now begins acquiring data for the calibration value. As data is gathered, the units for ppm and temperature may flash. Flashing units indicate that this parameter is unstable. The calibration data point acquisition will stop only when the data remains stable for a pre-determined amount of time. This can be overridden by pressing ENTER.
6. If the data remains unstable for 10 minutes, the calibration will fail and the message **Cal Unstable** will be displayed.
7. The screen will display the last measured ppm value and a message will be displayed prompting the user for the lab value. The user must then modify the screen value with the arrow keys and press ENTER. The system then performs the proper checks.
8. If accepted, the screen will display the message **PASS** with the new slope reading, then it will return to the main measurement display. If the calibration fails, a message indicating the cause of the failure will be displayed and the FAIL icon will be turned on.

6.3 D.O. Span Air Cal (%-sat)

This is the recommended method for air temperatures greater than about 5°C; however, it requires that the sensor be removed from the process and cleaned. Once cleaned, the sensor is held in air and allowed time to adjust to the air temperature. As the sensor temperature equilibrates, the transmitter automatically calculates the new 100% saturation point utilizing the temperature readings and the barometric pressure user data. This method therefore requires no user input during calibration. **Note: It is very important to allow enough time for the sensor to completely temperature equilibrate with the surrounding air. This time is at least 10 minutes.**

1. Remove the sensor from the process. Clean and rinse if necessary with water, paying particular attention to cleaning the face of the sensor.
2. Cover the sensor, if necessary, to shield it from the direct rays of the sun. Remember, the sensor must not be submerged - it must be in the air letting the sensor hang while powered.
3. Allow the system to operate undisturbed for at least 20 minutes. If the system is stable, the value on the display will increase to some PPM value and remain at that level. At that point, calibration can continue.
4. Scroll to the CAL menu section using the MENU key and press ENTER or the UP arrow key. **Cal D.O.** will then be displayed.
5. Press the ENTER key. The screen will display a flashing **1-spl** for 1-point, a **2-%sat** for Saturation air calibration, or a **3-zer** for zero calibration. Using the UP arrow key, set for a **2-sat** span calibration and press ENTER.

6. The display will prompt the user to hold the sensor in air and press ENTER. If the sensor has already been removed from the process and reached temperature equilibrium, press the ENTER key.
7. The system now begins acquiring data for the calibration value. As data is gathered, the units for ppm and temperature may flash. Flashing units indicate that this parameter is unstable.
8. The calibration data point acquisition will stop only when the data remains stable for a pre-determined amount of time (approximately 15-20 seconds.) This can be overridden by pressing ENTER. If the data remains unstable for 10 minutes, the calibration will fail and the message **CalUnstable** will be displayed.
9. If accepted, the screen will display the message **PASS** with the new sensor slope reading, then it will return to the main measurement display. If the calibration fails, a message indicating the cause of the failure will be displayed and the FAIL icon will be turned on.
10. The range of acceptable values for sensor slope is 20% to 500%. It may be necessary to rebuild the sensor as described in section 5, Dissolved Oxygen Sensor Assembly.

Should the slope value remain out of range and result in calibration failures, review the Service Section of this manual, then contact the Service Dept. at ATI for further assistance.

6.4 D.O. ZeroCal

Dissolved oxygen sensors have extremely low offset outputs at zero. For this reason, **it is normally sufficient to simply leave the zero at the factory default of 0 mV.**

1. Remove the sensor from the application if necessary. Clean and rinse if required.
2. Place about 3 inches of zero solution in a container large enough to immerse the end of the sensor. You can make a zero solution by adding about 2 teaspoons of powdered sodium sulfite to up to 1 liter of water. Allow the sensor to sit undisturbed for at least 1 hour. Suspend sensor, DO NOT LET SENSOR SIT ON TIP.

3. Scroll to the CAL menu section using the MENU key and press ENTER or the UP arrow key. **Cal D.O.** will then be displayed.
4. Press the ENTER key. The screen will display a flashing **1-spl** for 1-point, a **2-%sat** for Saturation calibration, or a **3-zer** for zero calibration. Using the UP arrow key, set for a **2-Zer** zero calibration and press ENTER.
5. The system now begins acquiring data for the sensor zero calibration value. As data is gathered, the units for sensor millivolts (mV) and temperature may flash. Flashing units indicate that this parameter is unstable. The calibration data point acquisition will stop only when the data remains stable for a pre-determined amount of time. This can be overridden by pressing ENTER.
6. If the data remains unstable for 10 minutes, the calibration will fail and the message **CalUnstable** will be displayed.
7. If accepted, the screen will display the message **PASS** with the new sensor zero reading (offset), then it will return to the main measurement display. If the calibration fails, a message indicating the cause of the failure will be displayed and the FAIL icon will be turned on. The range of acceptable value for sensor offset is -40 mV to +40 mV. Should the offset value remain high and result in calibration failures, review the Service section of this manual, and then contact the service dept. at ATI for further assistance.

The sensor offset value in mV from the last zero calibration is displayed on the lower line of the Default Menus for information purposes.

6.5 Temperature Calibration

Calibration of the temperature circuit is rarely ever required. The temperature calibration sequence is essentially a 1-point offset calibration that allows adjustments of approximately ± 5 °C. The sensor temperature may be calibrated on line, or the sensor can be removed from the process and placed into a known solution temperature reference.

In any case, it is critical that the sensor be allowed to reach temperature equilibrium with the solution in order to provide the highest accuracy.

When moving the sensor between widely different temperature conditions, it may be necessary to allow the sensor to stabilize as much as one hour before the calibration sequence is initiated. If the sensor is on-line, the user may want to set the output HOLD feature prior to calibration to lock out any output fluctuations.

1. Scroll to the CAL menu section using the MENU key and **press ENTER or the UP arrow key.**
2. Press the UP arrow key until **Cal Temp** is displayed.
3. Press the ENTER key. The message **Place sensor in solution then press ENTER** will be displayed. Move the sensor into the calibration reference (if it hasn't been moved already) and wait for temperature equilibrium to be achieved. Press ENTER to begin the calibration sequence.
4. The calibration data gathering process will begin. The message Wait will flash as data is accumulated and analyzed. The °C or °F symbol may flash periodically if the reading is too unstable.
5. The message **Adjust value - press ENTER** will be displayed, and the right-most digit will begin to flash, indicating that the value can be modified. Using the UP and LEFT arrow keys, modify the value to the known ref solution temperature. Adjustments up to ± 5 °C from the factory calibrated temperature are allowed. Press ENTER.
6. Once completed, the display will indicate **PASS** or **FAIL**. If the unit fails, the temperature adjustment may be out of range, the sensor may not have achieved complete temperature equilibrium, or there may be a problem with the temperature element. In the event of calibration failure, it is recommended to attempt the calibration again immediately.

Part 7 - Sensor Auto-Clean System

7.1 General

The cleaner control system located in the cleaner enclosure contains a number of components designed to supply pulses of high pressure air to the tip of the sensor. The main components and their function are as follows:

Compressor: The air compressor is a small DC powered diaphragm type compressor that delivers air at up to 30 PSI to the accumulator cylinder which is part of the system. The compressor cannot provide an output above 30 PSI (2 Bar) so no special pressure relief is required in the system.

Accumulator: The accumulator is a 3 1/2" diameter stainless steel chamber that is pressurized with air from the compressor. The accumulator allows a relatively high volume of air to be delivered with each cleaning pulse, increasing the effectiveness of the cleaner.

Solenoid Valve: The solenoid valve on the outlet of the accumulator controls the flow of cleaning pulses to the nozzle located on the sensor assembly. The solenoid is opened and closed under the control of the sequencing module.

The operation of the cleaner control system is completely automatic. There are no customer adjustments required. The only requirement is that the D.O. monitor be set for AUTO mode of operation and that the desired cleaning frequency be programmed.

7.2 Cleaner Sequence

The cleaner control system is designed to provide three 3-second pulses of pressurized air through a nozzle located within 1 inch of the sensor membrane. The nozzle directs the air blast at the center of the membrane, effectively blasting away accumulated coatings on the surface.

The cleaner sequence begins with the closure of relay D in the display module. The sequencing system contains a relay that turns on the compressor and releases air to the cleaner nozzle when the accumulator has been charged. The entire cycle takes about 90 seconds.

During the cycle, the compressor will run for 40 seconds to charge the accumulator. At this point, the sequencing system will open the solenoid valve for 3 seconds, discharging air through the solenoid valve and out to the cleaner nozzle at the sensor. This delivers a 3 second high velocity air blast across the membrane. After 3 seconds, the solenoid will close, allowing the accumulator to recharge for 20 seconds. This cycle repeats itself three times, after which the compressor shuts off. The solenoid will release the final air burst shortly after the compressor shuts off so that no pressure remains in the accumulator.

Once the air cleaning system has run through a cycle, it will remain in standby while waiting for the next activation signal from the D.O. monitor. This will normally occur every 24 hours, but can be activated manually at any time as explained previously.

The cleaner can be started **manually** any time the monitor is in operation. From the Measure Menu, press the UP arrow until the bottom line of the display indicates "Tcycle xx Hrs". Then press and hold the ENTER key for about 3 seconds to start the cleaning cycle. You will hear the compressor activate.

Part 8 - PID Controller Details

8.1 PID Description

PID control, like many other control schemes, is used in chemical control to improve the efficiency of chemical addition or control. By properly tuning the control loop that controls chemical addition, only the amount of chemical that is truly required is added to the system, saving money. The savings can be substantial when compared to a system which may be simply adding chemical at a constant rate to maintain some minimal addition under even the worst case conditions. The PID output controller is highly advantageous over simple control schemes that just utilize direct (proportional only) 4-20 mA output connections for control, since the PID controller can automatically adjust the “rate” of recovery based on the error between the setpoint and the measured value – which can be a substantial efficiency improvement..

The PID controller is basically designed to provide a “servo” action on the 4-20 mA output to control a process. If the user requires that a measured process stay as close as possible to a specific setpoint value, the controller output will change from 0% to 100% in an effort to keep the process at the setpoint. To affect this control, the controller must be used with properly selected control elements (valves, proper chemicals, etc.) that enable the controller to add or subtract chemical rapidly enough. This is not only specific to pumps and valves, but also to line sizes, delays in the system, etc.

This section is included to give a brief description of tuning details for the PID controller, and is not intended to be an exhaustive analysis of the complexities of PID loop tuning. Numerous sources are available for specialized methods of tuning that are appropriate for a specific application.

8.2 PID Algorithm

As most users of PID controllers realize, the terminology for the actual algorithm terms and even the algorithms themselves can vary between different manufacturers. This is important to recognize as early as possible, since just plugging in similar values from one controller into another can result in dramatically different results. There are various basic forms of PID algorithms that are commonly seen, and the implementation here is the most common version; The ISA algorithm (commonly referred to as the “ideal” algorithm.)

$$\text{output} = P \left[e(t) + \frac{1}{I} \int e(t) dt + D \frac{de(t)}{dt} \right]$$

Where:

| | |
|----------|---|
| output = | controller output |
| P = | proportional gain |
| I = | integral gain |
| D = | derivative gain |
| t = | time |
| e(t) = | controller error (e=measured variable – setpoint) |

Figure 19 - ISA PID Equation

The most notable feature of the algorithm is the fact the proportional gain term affects all components directly (unlike some other algorithms - like the “series” form.) If a pre-existing controller utilizes the same form of the algorithm shown above, it is likely similar settings can for made if the units on the settings are exactly the same. Be careful of this, as many times the units are the reciprocals of each other (i.e. reps-per-min, sec-per-rep.)

PID stands for “proportional, integral, derivative.” These terms describe the three elements of the complete controller action, and each contributes a specific reaction in the control process. The PID controller is designed to be primarily used in a “closed-loop” control scheme, where the output of the controller directly affects the input through some control device, such as a pump, valve, etc.

Although the three components of the PID are described in the setting area (section 6.25), here are more general descriptions of what each of the PID elements contribute to the overall action of the controller.

- P Proportional gain. With no “I” or “D” contribution, the controller output is simply a factor of the proportional gain multiplied by the input error (difference between the measured input and the controller setpoint.) Because a typical chemical control loop cannot react instantaneously to a correction signal, proportional gain is typically not efficient by itself – it must be combined with some integral action to be useful. Set the P term to a number between 2-4 to start. Higher numbers will cause the controller action to be quicker.

- I Integral gain. Integral gain is what allows the controller to eventually drive the input error to zero – providing accuracy to the control loop. It must be used to affect the accuracy in the servo action of the controller. Like proportional gain, increasing integral gain results in the control action happening quicker. Set the I term to a number between 3-5 to start (1-2 more than P). Like proportional gain, increasing the integral term will cause the controller action to be quicker.

- D Derivative gain. The addition of derivative control can be problematic in many applications, because it greatly contributes to oscillatory behavior. In inherently slow chemical control process', differential control is generally added in very small amounts to suppress erratic actions in the process that are non-continuous, such as pumps and valves clicking on and off. However, as a starting point for chemical process control, its best to leave the "D" term set to 0.

Based on these descriptions, the focus on tuning for chemical applications really only involves adjustment of "P" and "I" in most cases. However, increasing both increases the response of the controller. The difference is in the time of recovery. Although combinations of high "P's" and low "I" will appear to operate the same as combinations of low "P's" and high "I's", there will be a difference in rate of recovery and stability. Because of the way the algorithm is structured, large "P's" can have a larger impact to instability, because the proportional gain term impacts all the other terms directly. Therefore, keep proportional gain lower to start and increase integral gain to achieve the effect required.

Many of the classical tuning techniques have the user start with all values at 0, and then increase the P term until oscillations occur. The P value is then reduced to 1/2 of the oscillatory value, and the I term is increased to give the desired response. This can be done with the Q46D controller, with the exception that the I term should start no lower than 1.0.

If it appears that even large amounts of integral gain (>20) don't appreciably increase the desired response, drop I back to about 1.0, and increase P by 1.00, and start increasing I again. In most chemical control schemes, I will be approximately 3 times the value of P.

8.3 Classical PID Tuning

Unlike many high speed position applications where PID loops are commonly used, the chemical feed application employed by this instrument does not require intense mathematical exercise to determine tuning parameters for the PID. In fact, the risk of instability is far greater with overly tuned PID control schemes. In addition, many of the classical mathematical exercises can be damaging or wasteful in the use of chemicals when the process is bumped with large amounts of input error to seek a response curve. Because of this, the general adjustment guidelines described in section 8.2 are sufficient for almost all application tuning for this instrument. Beyond this, many sources are available for classical tuning methods.

8.4 Manual PID Override Control

The Q46 electronics is equipped designed to allow the user to take manual control of the PID output. This is often useful when starting up a control loop, or in the event that you wish to bump the system manually to measure system response time.

To access the manual PID control, you must be in the MEASURE mode of operation and you must have the PID output displayed on the lower line. This line will indicate “XX.X% XX.X mA” with the X values simply indicating the current values. With this display on the screen, press and hold the ENTER key for about 5 seconds. You will see a small “m” show up between the % value and the mA value. This indicates you are now in manual mode.

Once in manual, you may increase the PID output by pressing the UP arrow or you may decrease the output by pressing the LEFT arrow. This will allow you to drive the PID output to any desired setting.

To revert to normal PID control, press and hold the ENTER key again until the “m” indicator disappears.

8.5 Common PID Pitfalls

The most common problem occurring in PID control applications involves the false belief that proper settings on only the PID controller can balance any process to an efficient level.

Close-loop control can only be effective if all elements in the loop are properly selected for the application, and the process behavior is properly understood. Luckily, the nature of simple chemical control process' are generally slow in nature. Therefore, even a de-tuned controller (one that responds somewhat slow) can still provide substantial improvements to setpoint control. In fact, damaging oscillatory behavior is far more likely in tightly tuned controllers where the user attempted to increase response too much.

When deciding on a PID control scheme, it is important to initially review all elements of the process. Sticking valves, undersized pumps, or delays in reaction times associated with chemical addition can have a dramatic effect on the stability of the control loop. When controlling a chemical mix or reaction, the sensor should be placed in a location that ensures proper mixing or reaction time has occurred.

The easiest process' to control with closed-loop schemes are generally linear, and symmetrical, in nature. For example, controlling level in tank where the opening of valve for a fixed period of time corresponds linearly to the amount that flows into a tank. Chemical control process' can be more problematic when the nature of the setpoint value is non-linear relative to the input of chemical added. For example, D.O. control of a process may appear linear only in a certain range of operation, and become highly exponential at the extreme ranges of the measuring scale. In addition, if a chemical process is not symmetrical, that means it responds differentially to the addition and subtraction of chemical. It is important in these applications to study steady-state impact as well as step-change impact to process changes. In other words, once the process has apparently been tuned under normal operating conditions, the user should attempt to force a dramatic change to the input to study how the output reacts. If this is difficult to do with the actual process input (the recommended method), the user can place the control in manual at an extreme control point such as 5% or 95%, and release it in manual. The recovery should not be overly oscillatory. If so, the loop needs to be de-tuned to deal with that condition (reduce P and/or I.)

Part 9 - System Maintenance

9.1 General

The Q46D/60 Dissolved oxygen System will generally provide unattended operation over long periods of time. With proper care, the system should continue to provide measurements indefinitely. For reliable operation, maintenance on the system must be done on a regular schedule. Keep in mind that preventive maintenance on a regular schedule is much less troublesome than emergency maintenance that always seems to come at the wrong time.

9.2 Analyzer Maintenance

No unusual maintenance of the analyzer is required if installed according to the guidelines of this operating manual. If the enclosure door is frequently opened and closed, it would be wise to periodically inspect the enclosure sealing gasket for breaks or tears.

9.3 Sensor Maintenance

Very little sensor maintenance is required for an optical D.O. system. The primary requirement is simply to keep the sensing area clean. Visually inspect the sensor every few weeks to verify the sensing area is clean. Wipe with a soft cloth, if necessary.

The life of the optical element is likely to be greater than 2 years, but less than 5 years. When the optical sensing element is expended, a new one can easily be installed.

Part 10 - Troubleshooting

10.1 General

The information included in this section is intended to be used in an attempt to quickly resolve an operational problem with the system. During any troubleshooting process, it will save the most time if the operator can first determine if the problem is related to the analyzer, sensor, or some external source. Therefore, this section is organized from the approach of excluding any likely external sources, isolating the analyzer, and finally isolating the sensor. If these procedures still do not resolve the operational problems, any results the operator may have noted here will be very helpful when discussing the problem with the factory technical support group.

10.2 External Problem Sources

To begin this process, review the connections of the system to all external connections.

1. Verify the analyzer is earth grounded. For all configurations of the analyzer, an earth ground connection **MUST** be present for the shielding systems in the electronics to be active. Grounded conduit provides no earth connection to the plastic enclosure, so an earth ground wiring connection must be made at the power input terminal strip. Use the special "shield terminal" stub on the power supply board for optimum sensor cable shield grounding.
2. Verify the proper power input is present (90-260 VAC or 12-24 VDC.)
3. Verify the loads on any 4-20 mA outputs do not exceed the limits in the Instrument Specifications (500 Ohms each for analyzer.) During troubleshooting, it is many times helpful to disconnect all these outputs and place wire-shorts across the terminals in the instrument to isolate the system and evaluate any problems which may be coming down the analog output connections.
4. Do not run sensor cables or analog output wiring in the same conduits as power wiring. If low voltage signal cables must come near power wiring, cross them at 90° to minimize coupling.

5. If rigid conduit has been run directly to the Q46 enclosure, check for signs that moisture has followed conduit into the enclosure.
6. Check for ground loops. Although the membrane sensor is electrically isolated from the process water, high frequency sources of electrical noise may still cause erratic behavior in extreme conditions. If readings are very erratic after wiring has been checked, check for a possible AC ground loop by temporarily placing the sensor into a bucket of water. The reading should be initially stable and then fall very slowly in a smooth fashion as the powered sensor depletes oxygen in the static sample directly at the sensor face.
7. On relay based systems, check the load that is connected to the relay contacts. Verify the load is within the contact rating of the relays. Relay contacts which have been used for higher power AC current loads may become unsuitable for very low signal DC loads later on because a small amount of pitting can form on the contacts. If the load is highly inductive (solenoids, motor starters, large aux relays), note that the contact rating will be de-rated to a lower level. Also, due to the large amount of energy present in circuits driving these types of loads when they are switched on an off, the relay wiring placement can result in electrical interference for other devices. This can be quickly resolved by moving wiring, or by adding very inexpensive snubbers (such As Quencharcs) to the load.
8. Carefully examine any junction box connections for loose wiring or bad wire stripping. If possible, connect the sensor directly to the analyzer for testing.
9. Check sensor membrane for fouling. Look closely for signs of grease or oil which may be present.

10.3 Analyzer Tests

1. Disconnect power and completely disconnect all output wiring coming from the analyzer. Remove sensor wiring, relay wiring, and analog output wiring. Re-apply power to the analyzer. Verify proper voltage (90-260 VAC or 12-24 VDC) is present on the incoming power strip of the analyzer, and that the analyzer power label matches the proper voltage value.
2. If analyzer does not appear to power up (no display), remove power and check removable fuse for continuity with a DVM.
3. Using a DVM, check the voltage across the BLUE and WHITE wires coming from the power supply board in the base of the enclosure. FIRST, disconnect any wiring going to lout#1. Then, verify voltage across these wires is about 16-18 VDC when still connected to the terminal strip on the front half of the enclosure. If the BLUE and WHITE wires are not connected to the terminal strip on the front half of the enclosure, the voltage across them should measure about 29 VDC.
4. If analyzer does power up with a display, use the "Simulate" feature to check operation of the analog outputs (and relays contacts with a DVM.)
5. Check sensor power circuits. With a DVM, verify between -4.5 and -5.5 VDC from sensor connection terminals WHITE (+) to BLACK (-). Then verify between +4.5 and +5.5 VDC from GREEN (+) to BLACK (-).
6. Check TC drive circuit. Place a wire-short between the RED and BLACK sensor terminals. With a DVM, measure the voltage between the BLACK (-) and BROWN (+) sensor terminals to verify that the TC drive circuit is producing about -4.6 to -5.5 VDC open-circuit. Remove DVM completely and connect a 1000 Ohm resistor across the BLACK to BROWN terminals. The temperature reading on the front LCD should display approximately 0°C and the dissolved oxygen reading should display approximately 0 ppm.

10.31 Display Messages

The Q46 Series instruments provide a number of diagnostic messages which indicate problems during normal operation and calibration. These messages appear as prompts on the secondary line of the display or as items on the Fault List.

| MESSAGE | DESCRIPTION | POSSIBLE CORRECTION |
|---------------------|---|--|
| Max is 200 | Entry failed, maximum user value allowed is 200. | Reduce value to ≤ 200 |
| Min is 200 | Entry failed, minimum value allowed is 200. | Increase value to ≥ 200 |
| Cal Unstable | Calibration problem, data too unstable to calibrate. Icons will not stop flashing if data is too unstable. User can bypass by pressing ENTER. | Clean sensor, get fresh cal solutions, allow temperature and conductivity readings to fully stabilize, do not handle sensor or cable during calibration. |
| Out of Range | Input value is outside selected range of the specific list item being configured. | Check manual for limits of the function to be configured. |
| Locked! | Transmitter security setting is locked. | Enter security code to allow modifications to settings. |
| Unlocked! | Transmitter security has just been unlocked. | Displayed just after security code has been entered. |
| Offset High | The sensor zero offset point is out of the acceptable range of -40 to +40 mV. | Check wiring connections to sensor. Allow sensor to operate powered a minimum of 12 hours prior to first zero cal. |
| Sensor High | The raw signal from the sensor is too high and out of instrument range. | Check wiring connections to sensor. |
| Sensor Low | The raw signal from the sensor is too low. | Check wiring connections to sensor. |
| D.O. High | The oxygen reading is greater than the maximum of the User-selected range. | The oxygen reading is over operating limits. Set measuring range to the next highest level. |
| Temp High | The temperature reading is $> 55^{\circ}\text{C}$. | The temperature reading is over operating limits. Check wiring and expected temp level. Perform RTD test as described in sensor manual. Recalibrate sensor temperature element if necessary. |
| Temp Low | The temperature reading is $< -10^{\circ}\text{C}$ | Same as "Temp High" above. |
| TC Error | TC may be open or shorted. | Check sensor wiring and perform RTD test as described in sensor manual. Check j-box connections. |

Figure 20 - Q46D Display Messages

| MESSAGE | DESCRIPTION | POSSIBLE CORRECTION |
|-----------------------|---|---|
| D.O. Cal Fail | Failure of oxygen calibration. FAIL icon will not extinguish until successful calibration has been performed, or 30 minutes passes with no keys being pressed. | Clean sensor redo zero and span calibration. If still failure, sensor slope may be less than 20% or greater than 500%. Perform sensor tests as described in section 10.4. Replace sensor if still failure. |
| TC Cal Fail | Failure of temperature calibration. FAIL icon will not extinguish until successful calibration has been performed, or 30 minutes passes with no keys being pressed. | Clean sensor, check cal solution temperature and repeat sensor temp calibration. TC calibration function only allows adjustments of +/- 6 °C. If still failure, perform sensor tests as described in section 10.4. Replace sensor if still failure. |
| EPROM Fail | Internal nonvolatile memory failure | System failure, consult factory. |
| Chcksum Fail | Internal software storage error. | System failure, consult factory. |
| Display Fail | Internal display driver fail. | System failure, consult factory. |
| Range Cal Fail | Failure of factory temperature calibration. | Consult factory. |

10.4 Sensor Tests

1. Check the condition of the optical sensing element. Mechanical damage to the black covering over the optical element is an indication that sensor problems are likely.
2. Prior to disconnecting the sensor, measure the sensor output voltage at the analyzer terminal strip with a DVM while the sensor is hanging in air. If the sensor has been connected to a powered analyzer for at least 2 hours, the nominal output of the sensor will be about +400mVDC when measured in air at 25C (100% saturation) from BLACK (-) to RED (+) on the analyzer terminal strips. This value is affected by temperature, pressure, and age of the sensor so it's possible to see a typical value that ranges from perhaps +200mVDC to about +800 mVDC under a wide range of conditions in air.
3. Disconnect the five sensor wires from the oxygen monitor. Those wires are color coded red, white, blue, green, brown, and black. Note: the brown wire may be replaced by an orange wire in some cables. Connect the DVM between the brown and black wires. These are the RTD leads, and you should find a resistance value that depends on the temperature. The table below lists the resistance values for various temperatures.

| Temperature °C | Resistance Ω |
|-------------------|-----------------|
| 0 | 1000 |
| 5 | 1019 |
| 10 | 1039 |
| 15 | 1058 |
| 20 | 1078 |
| 25 | 1097 |
| 30 | 1117 |
| 35 | 1136 |
| 40 | 1155 |
| 45 | 1175 |
| 50 | 1194 |

Figure 21 - Pt1000 RTD Table

| Barometric Pressure Conversion | | |
|---------------------------------------|--------------------------------------|-----------------------------|
| Inches of Mercury(inHg) | Millimeters of Mercury (mmHg) | Feet Above Sea Level |
| 22.00 | 558.8 | +8790 |
| 22.50 | 571.5 | +8053 |
| 23.00 | 584.2 | +7347 |
| 23.50 | 596.9 | +6671 |
| 24.00 | 609.6 | +6023 |
| 24.50 | 622.3 | +5402 |
| 25.00 | 635.0 | +4806 |
| 25.50 | 647.7 | +4233 |
| 26.00 | 660.4 | +3682 |
| 26.50 | 673.1 | +3156 |
| 27.00 | 685.5 | +2653 |
| 27.50 | 698.5 | +2150 |
| 28.00 | 711.2 | +1675 |
| 28.50 | 723.9 | +1217 |
| 29.00 | 736.6 | +776 |
| 29.50 | 749.3 | +349 |
| 30.00 | 762.0 | -64 |
| 30.50 | 774.7 | -463 |
| 31.00 | 784.4 | -759 |

Figure 22 - Reference, Barometric Conversion Table

Spare Parts

| <u>PART NO.</u> | <u>DESCRIPTION</u> |
|-----------------|--|
| 03-0393 | Q46D Front Lid Assembly |
| 07-0320 | AC Powered Analyzer Electronics Assembly, 90-260 VAC |
| 07-0321 | DC Powered Analyzer Electronics Assembly, 12-24 VDC |
| 07-0322 | AC Powered Analyzer Electronics Assembly, w/Profibus |
| 07-0323 | DC Powered Analyzer Electronics Assembly, w/Profibus |
| 01-0317 | 90-260 VAC Q-Blast PCB Assy |
| 03-0341 | 12-24 VDC Q-Blast PCB Assy |
| 31-0001 | 5 Cond. 22 Awg Cable |
| | |
| 63-0100 | Submersible O.D.O. Sensor with 30 ft cable |
| | |
| 36-0040 | Compression Pump, 12VDC |
| 36-0041 | Pump Mounting Kit |
| 36-0039 | Solenoid Valve, 12VDC |
| 44-0040 | PVC Tubing |
| 23-0022 | Fuse, 250mA, 250V, TR-5 (for AC and DC Analyzers) |
| 38-0073 | Terminal block plug, 4 position (outputs) |
| 38-0072 | Terminal block plug, 3 position (relays) |
| 38-0075 | Terminal block plug, 3 position (power) |
| 38-0074 | Terminal block plug, 3 position (shields) |
| 31-0173 | 20 Pos. Ribbon cable assembly for AC units |
| 44-0276 | Polyurethane Tubing, Black (sold /ft.) |

Lock/Unlock Code: 1463