

# **Model Q46D/60**

## **Dissolved Oxygen Measurement System**

---

### **Home Office**

Analytical Technology, Inc.  
6 Iron Bridge Drive  
Collegeville, PA 19426

Ph: 800-959-0299

610-917-0991

Fax: 610-917-0992

Email: [sales@analyticaltechnology.com](mailto:sales@analyticaltechnology.com)

### **European Office**

ATI (UK) Limited  
Unit 1 & 2 Gatehead Business Park  
Delph New Road, Delph  
Saddleworth OL3 5DE

Ph: +44 (0)1457-873-318

Fax: + 44 (0)1457-874-468

Email: [sales@atiuk.com](mailto:sales@atiuk.com)

---

# PRODUCT WARRANTY

Analytical Technology, Inc. (Manufacturer) warrants to the Customer that if any part(s) of the Manufacturer's equipment proves to be defective in materials or workmanship within the earlier of 18 months of the date of shipment or 12 months of the date of start-up, such defective parts will be repaired or replaced free of charge. Inspection and repairs to products thought to be defective within the warranty period will be completed at the Manufacturer's facilities in Collegeville, PA. Products on which warranty repairs are required shall be shipped freight prepaid to the Manufacturer. The product(s) will be returned freight prepaid and allowed if it is determined by the manufacturer that the part(s) failed due to defective materials or workmanship.

This warranty does not cover consumable items, batteries, or wear items subject to periodic replacement including lamps and fuses.

Gas sensors carry a 12 months from date of shipment warranty and are subject to inspection for evidence of misuse, abuse, alteration, improper storage, or extended exposure to excessive gas concentrations. Should inspection indicate that sensors have failed due to any of the above, the warranty shall not apply.

The Manufacturer assumes no liability for consequential damages of any kind, and the buyer by acceptance of this equipment will assume all liability for the consequences of its use or misuse by the Customer, his employees, or others. A defect within the meaning of this warranty is any part of any piece of a Manufacturer's product which shall, when such part is capable of being renewed, repaired, or replaced, operate to condemn such piece of equipment.

This warranty is in lieu of all other warranties (including without limiting the generality of the foregoing warranties of merchantability and fitness for a particular purpose), guarantees, obligations or liabilities expressed or implied by the Manufacturer or its representatives and by statute or rule of law.

This warranty is void if the Manufacturer's product(s) has been subject to misuse or abuse, or has not been operated or stored in accordance with instructions, or if the serial number has been removed.

Analytical Technology, Inc. makes no other warranty expressed or implied except as stated above.

# Table of Contents

---

<b>PART 1 - INTRODUCTION .....</b>	<b>5</b>	<b>PART 7 – CALIBRATION .....</b>	<b>51</b>
1.1 General.....	5	7.1 Oxygen Calibration .....	51
1.2 Standard System.....	5	7.11 Oxygen Span Cal .....	51
1.3 Features .....	5	7.12 D.O. Span Cal (1-spl).....	51
6		7.13 D.O. Air Span Cal (% sat) .....	52
1.4 Q46D/60 System Specifications.....	7	7.14 Dissolved Oxygen Zero Cal .....	54
1.5 Q46D Performance Specifications.....	8	7.2 Temperature Calibration .....	55
<b>PART 2 – ANALYZER MOUNTING.....</b>	<b>9</b>	<b>PART 8 – PID CONTROLLER DETAILS .....</b>	<b>56</b>
2.1 General.....	9	8.1 PID Description .....	56
2.2 Wall or Pipe Mount.....	10	8.2 PID Algorithm.....	56
2.3 Panel Mount, AC Powered Monitor... ..	12	8.3 Classical PID Tuning.....	58
<b>PART 3 – SENSOR MOUNTING .....</b>	<b>13</b>	8.4 Manual PID Override Control.....	59
3.1 General.....	13	8.5 Common PID Pitfalls.....	59
3.2 Submersion Mounting .....	13	<b>PART 9 – SYSTEM MAINTENANCE .....</b>	<b>61</b>
3.3 Flowcell Mounting .....	14	9.1 General .....	61
3.4 Sealed Flowcell .....	15	9.2 Analyzer Maintenance .....	61
<b>PART 4 – ELECTRICAL INSTALLATION.....</b>	<b>16</b>	9.3 Sensor Maintenance .....	61
4.1 General.....	16	9.31 Lead Anode Replacement.....	62
4.2 AC Powered Instrument Wiring.....	17	9.32 Pressure Compensator Rebuild .....	62
4.3 Relay Connection.....	19	<b>PART 10 – TROUBLESHOOTING .....</b>	<b>63</b>
4.4 Optional Output/Relay Connection ...	20	10.1 General .....	63
4.5 Sensor Wiring.....	21	10.2 External .....	63
4.6 Direct Sensor Connection .....	22	10.3 Analyzer .....	65
4.7 Junction Box Connection .....	23	10.31 Display .....	65
<b>PART 5 – SENSOR ASSEMBLY.....</b>	<b>24</b>	10.4 Sensor.....	68
5.1 Oxygen Sensor Preparation.....	24	<b>SPARE PARTS.....</b>	<b>72</b>
5.2 Flow Type D.O. Sensor.....	26		
<b>PART 6 – CONFIGURATION .....</b>	<b>27</b>		
6.1 User Interface.....	27		
6.11 Keys.....	28		
6.12 Display.....	28		
6.2 Software .....	30		
6.21 Software Navigation .....	30		
6.22 Measure Menu [MEASURE].....	33		
6.23 Calibration Menu [CAL].....	34		
6.24 Configuration Menu [CONFIG].....	35		
6.25 Control Menu [CONTROL] .....	39		
.....	44		
6.26 Diagnostics Menu [DIAG].....	46		

# Table of Figures

---

<i>FIGURE 1 – Q46 ENCLOSURE DIMENSIONS</i> .....	9
<i>FIGURE 2 - WALL OR PIPE MOUNT BRACKET</i> .....	10
<i>FIGURE 3 - WALL MOUNTING DIAGRAM</i> .....	11
<i>FIGURE 4 - PIPE MOUNTING DIAGRAM</i> .....	11
<i>FIGURE 5 - PANEL MOUNT INSTALLATION</i> .....	12
<i>FIGURE 6 - SUBMERSIBLE SENSOR MOUNTING</i> .....	13
<i>FIGURE 7 - CONSTANT HEAD FLOWCELL DIMENSIONS</i> .....	14
<i>FIGURE 8 - SEALED FLOWCELL DIMENSIONS</i> .....	15
<i>FIGURE 9 - AC POWER CONNECTIONS</i> .....	18
<i>FIGURE 10 - RELAY CONTACTS</i> .....	19
<i>FIGURE 11 - OPTIONAL LOW POWER RELAY WIRING</i> .....	20
<i>FIGURE 12 - OPTIONAL 3RD ANALOG OUTPUT WIRING</i> .....	20
<i>FIGURE 13 - SUBMERSIBLE SENSOR CONNECTION</i> .....	21
<i>FIGURE 14 - SENSOR CABLE PREPARATION</i> .....	22
<i>FIGURE 15 - JUNCTION BOX INTERCONNECT WIRING</i> .....	23
<i>FIGURE 16 - SUBMERSIBLE SENSOR ASSEMBLY</i> .....	24
<i>FIGURE 17 - SUBMERSIBLE SENSOR MODULE EXPLODED VIEW</i> .....	25
<i>FIGURE 18 - FLOW TYPE D.O. SENSOR ASSEMBLY</i> .....	26
<i>FIGURE 19 - USER INTERFACE</i> .....	27
<i>FIGURE 20 - SOFTWARE MAP</i> .....	32
<i>FIGURE 21 - CONTROL RELAY EXAMPLE, HYSTERESIS &amp; PHASE OPTIONS</i> .....	43
<i>FIGURE 22 - ALARM RELAY EXAMPLE</i> .....	44
<i>FIGURE 23 - ISA PID EQUATION</i> .....	57
<i>FIGURE 24 - DISPLAY MESSAGES</i> .....	66
<i>FIGURE 25 - PT100 RTD RESISTANCE TABLE</i> .....	69
<i>FIGURE 26 - REFERENCE, BAROMETRIC CONVERSION TABLE</i> .....	70

# Part 1 - Introduction

---

## 1.1 General

The Model Q46D is a versatile on-line monitoring system designed for the continuous measurement of dissolved oxygen in solution. The full scale operating range of the system 0-40 ppm, and the sensing system will operate on water streams with temperatures ranging from 0 to 50°C.

The basic sensing element used in the dissolved oxygen monitor is a galvanic membrane sensor which measures oxygen directly.

Q46/60 Monitors are available in two electronic versions, an AC powered monitor with integral alarm relays and dual 4-20 mA output capability, and a 12-24 VDC unit with dual output and relays. Options are available to add either a third 4-20 mA output or 3 additional low power SPST relays. In addition, a digital output option for Profibus, Modbus, or Ethernet is available.

## 1.2 Standard System

The standard model Q46D/60 system includes two components, the Q46D analyzer and a dissolved oxygen sensor. For connection of the sensor to the electronics, a 25' cable is supplied. Up to an additional 1000 feet of interconnect cable may be added using #07-0100 junction box. All required spare parts are also provided with the basic system, including spare membranes, electrolyte, o-rings, and any special hardware.

## 1.3 Features

- Standard Q46D electronic transmitters are designed to be a fully isolated instruments for operation from either 90-260 VAC or 12-24 VDC power supplies.
- High accuracy, high sensitivity system, measures from 0.1 ppm to 40.0 ppm through 2 internal automatic ranges.
- Two 4-20 mA analog outputs are standard, and a third analog output is available as an option. One output may be configured for PID control, while other outputs are programmable to track either D.O. or Temperature.
- Selectable PID controller on main analog output. PID includes manual operation feature, and diagnostic “stuck-controller” timer feature for relay notification of control problems.

- Digital communication option for Profibus-DP, Modbus-RTU. More versions pending. See Q46 Digital Communications Manual for Specifications.
- Output Hold, Output Simulate, Output Alarm, and Output Delay Functions. All forced changes in output condition include bumpless transfer to provide gradual return to on-line signal levels and to avoid system control shocks on both analog outputs.
- Units provide provides three SPDT relay outputs and two isolated analog outputs. Software settings for relay control include setpoint, deadband, phase, delay, and failsafe.
- Selectable Output Fail Alarm feature on Relay C allows system diagnostic failures to be sent to external monitoring systems.
- Large, high contrast, custom LCD display with LED back light provides excellent readability in any light conditions. The secondary line of display utilizes 5x7 dot matrix characters for clear message display two of four measured parameters may be on the display simultaneously.
- Diagnostic messages provide a clear description of any problem with no confusing error codes to look up. Messages are also included for diagnosing calibration problems.
- Quick and easy one-point calibration method, air calibration method, and sensor zero-cal. To provide high accuracy, all calibration methods include stability monitors that check temperature and main parameter stability before accepting data.
- High accuracy three-wire Pt100 temperature input. Temperature element can be user calibrated.
- Security lock feature to prevent unauthorized tampering with transmitter settings. All settings can be viewed while locked, but they cannot be changed.



Equipment bearing this marking may not be discarded by traditional methods in the European community after August 12 2005 per EU Directive 2002/96/EC. End users must return old equipment to the manufacturer for proper disposal.

## 1.4 Q46D/60 System Specifications

<b>Displayed Parameters</b>	Main input, 0.1 ppm to 40.0 ppm %Saturation, 0 to 999.9% Sensor temperature, -10.0 to 50.0°C (23 to 122°F) Sensor signal, -40 to +2000 mVDC Loop current, 4.00 to 20.00 mA Sensor slope/offset Model number and software version PID Controller Status
<b>Main Parameter Ranges</b>	Manual selection of one of the following display ranges, 0.00 to 40.00 <b>ppm</b> or 0.00 to 40.00 <b>mg/l</b> 0.0 to 999.9% Saturation
<b>Power</b>	<b>90 - 260 VAC</b> , 50/60 Hz., 10 VA Maximum 12-24 VDC, 500 mA max.
<b>Display</b>	0.75" (19.1 mm) high 4-digit main display with sign 12-digit secondary display, 0.3" (7.6 mm) 5x7 dot matrix. Integral LED back-light for visibility in the dark.
<b>Enclosure</b>	NEMA 4X, polycarbonate, stainless steel hardware,
<b>Mounting Options</b>	Wall, pipe, or panel mount standard. Wall bracket suitable for either 1.5" or 2" I.D. U-Bolts for pipe mounting.
<b>Conduit Openings</b>	Five ½" NPT openings, Adapter can be removed to provide a 1" NPT opening in the bottom of the enclosure. Gland seals provided but not installed.
<b>Relays, Electromechanical:</b>	Three SPDT, 6 amp @ 250 VAC, 5 amp @ 24 VDC contacts. Software selection for setpoint, phase, delay, deadband, hi-lo alarm, and failsafe. A-B indicators on main LCD, and C indicator on lower display.
<b>Analog Outputs</b>	Two 4-20 mA outputs. Output one programmable for PPM D.O. or PID. Output 2 programmable for PPM D.O. or Temperature. Max load 450 Ohms for output 1 and 1000 ohms for output 2. Outputs ground isolated and isolated from each other. An additional 3 <sup>rd</sup> analog option is available.
<b>Output Isolation</b>	600 V galvanic isolation
<b>Optional Relays:</b>	Three SPST, 1 amp @ 24 VDC. Software selection for setpoint, phase, delay, deadband, hi-lo alarm, and failsafe.
<b>Ambient Temperature</b>	Analyzer Service, -20 to 60 °C (-4 to 140 °F)

	Sensor Service, -5 to 55°C (23 to 131 °F) Storage, -30 to 70 °C (-22 to 158 °F)
<b>Keypad</b>	4-key membrane type with tactile feedback, polycarbonate with UV coating
<b>Filter</b>	Adjustable 0-9.9 minutes to 90% input step change
<b>Temperature Input</b>	Pt1000 RTD with automatic compensation
<b>Ambient Humidity</b>	0 to 95%, indoor/outdoor use, non-condensing to rated ambient temperature range
<b>Altitude</b>	Up to 2000 m (6562 ft)
<b>Electrical Certification</b>	Ordinary Location, cCSAus (Certified to both CSA and UL standards), pollution degree 2, installation category 2
<b>EMI/RFI Influence</b>	Designed to EN 61326-1
<b>Weight</b>	2.4 lb. (1.1 Kg.)
<b>Sensor</b>	2-electrode galvanic membraned sensor for direct measurement of oxygen,
<b>Sensor Materials</b>	Noryl, PVC, and stainless steel
<b>Sensor Cable</b>	Submersible: 30 ft. (9.1 m)
<b>Max. Sensor Cable Length:</b>	1000 feet (300 m), with junction box

**1.5 Q46D Performance Specifications**

<b>Accuracy</b>	0.5% of selected range or better
<b>Repeatability</b>	0.3% of selected range or better
<b>Sensitivity</b>	0.05% of selected range
<b>Non-linearity</b>	0.1% of selected range
<b>Warm-up Time</b>	3 seconds to rated performance (electronics only)
<b>Supply Voltage Effects</b>	± 0.05% span
<b>Instrument Response Time</b>	60 seconds to 90% of step input at lowest damping



# Part 2 – Analyzer Mounting

## 2.1 General

All Q46 Series instruments offer maximum mounting flexibility. A bracket is included with each unit that allows mounting to walls or pipes. In all cases, choose a location that is readily accessible for calibrations. Also consider that it may be necessary to utilize a location where solutions can be used during the calibration process. To take full advantage of the high contrast display, mount the instrument in a location where the display can be viewed from various angles and long distances.

Locate the instrument in close proximity to the point of sensor installation - this will allow easy access during calibration. The sensor-to-instrument distance should not exceed 200 feet (61 m). To maximize signal-to-noise ratio however, work with the shortest sensor cable possible. The standard cable length of the oxygen sensor is 30 feet.

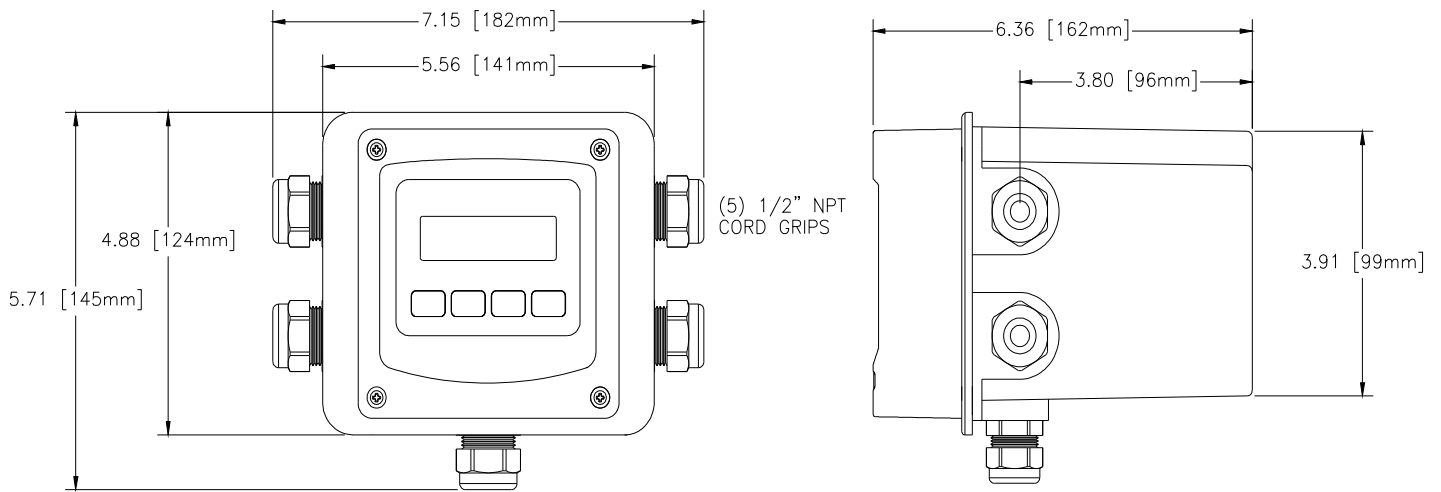

**Figure 1 – Q46 Enclosure Dimensions**

**2.2 Wall or Pipe Mount**

A PVC mounting bracket with attachment screws is supplied with each transmitter (see Figure 2 for dimensions). The multi-purpose bracket is attached to the rear of the enclosure using the four flat head screws. The instrument is then attached to the wall using the four outer mounting holes in the bracket. These holes are slotted to accommodate two sizes of u-bolt that may be used to pipe mount the unit. Slots will accommodate u-bolts designed for 1½” or 2” pipe. The actual center to center dimensions for the u-bolts are shown in the drawing. Note that these slots are for u-bolts with ¼-20 threads. The 1½” pipe u-bolt (2” I.D. clearance) is available from ATI in type 304 stainless steel under part number 47-0005

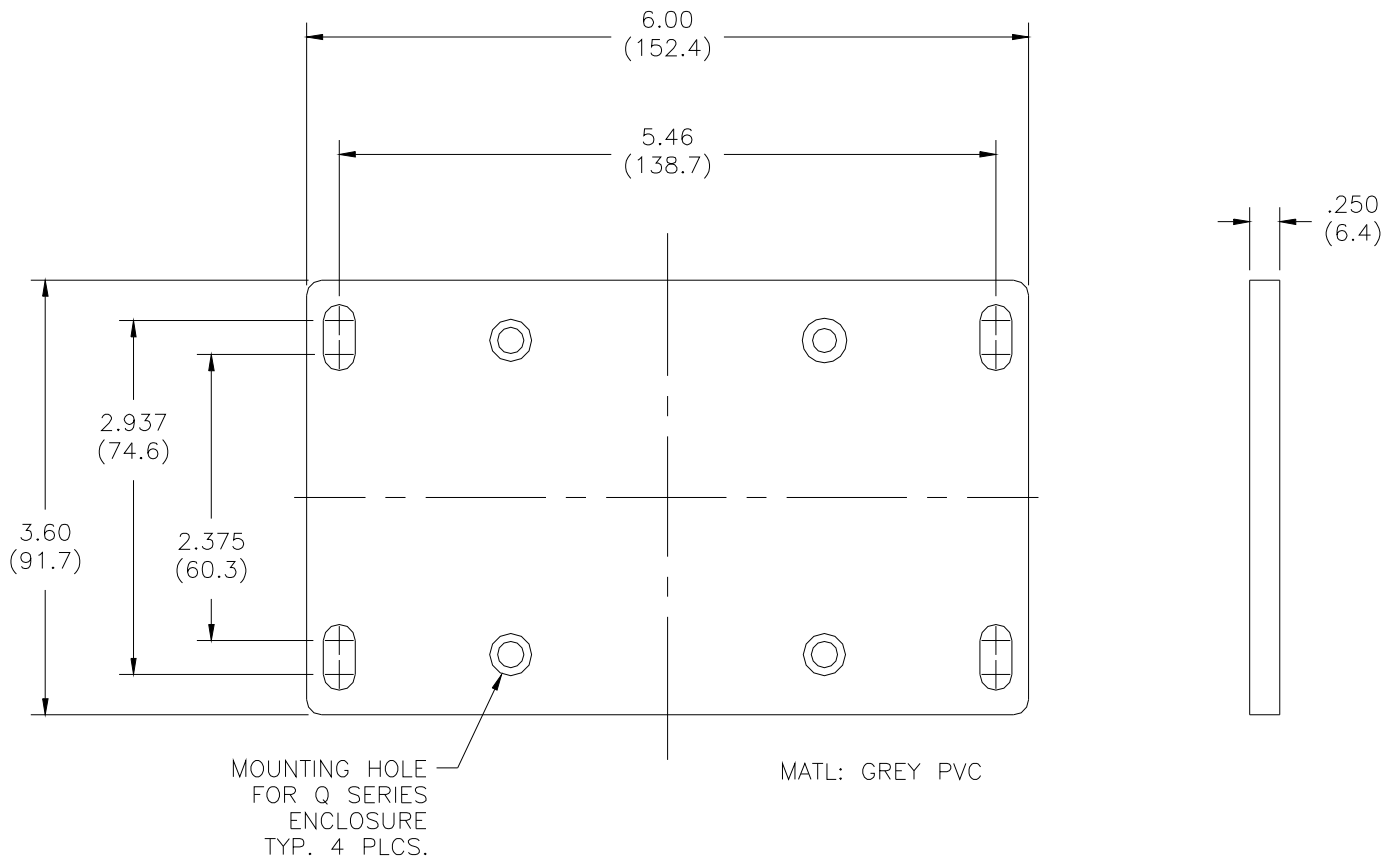

**Figure 2 - Wall or Pipe mount bracket**

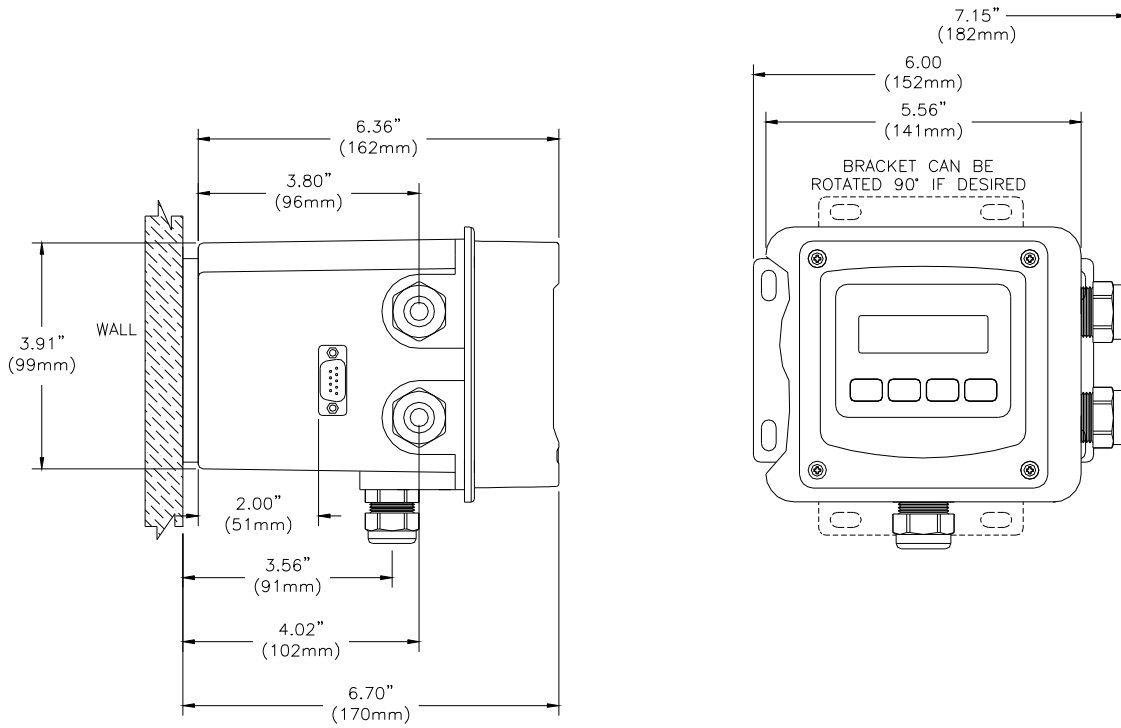

Figure 3 - Wall Mounting Diagram

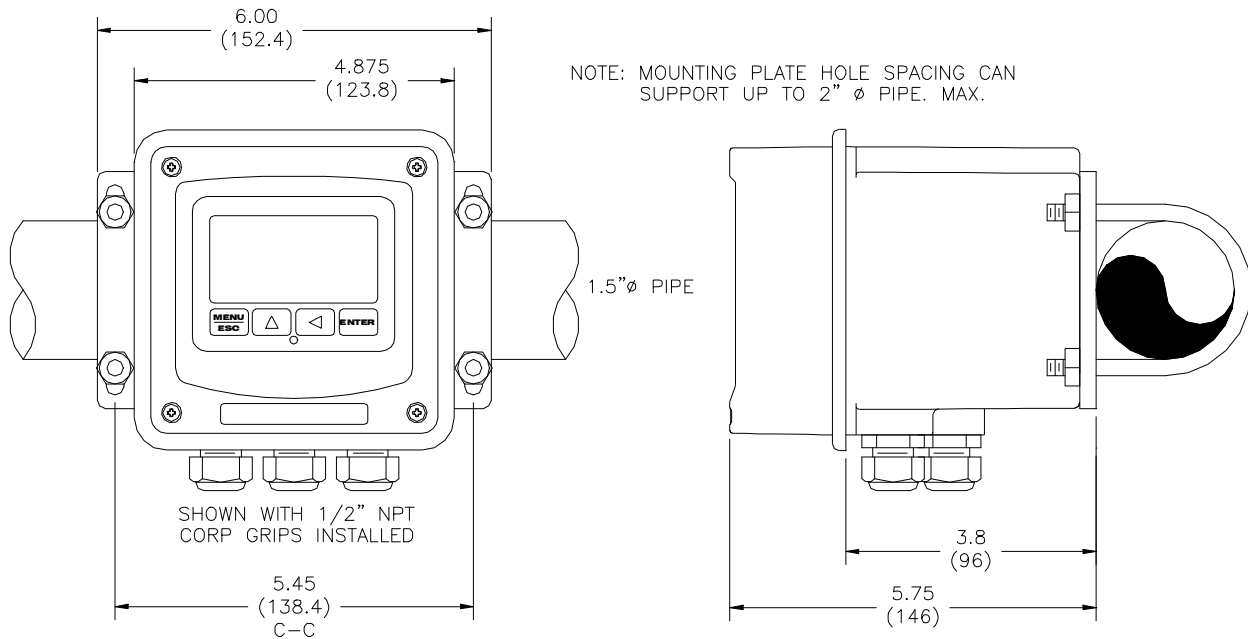

Figure 4 - Pipe Mounting Diagram

### 2.3 Panel Mount, AC Powered Monitor

Panel mounting of an AC powered monitor uses the panel mounting flange molded into the rear section of the enclosure. Figure 5 provides dimensions for the panel cutout required for mounting.

The panel mounting bracket kit must be ordered separately (part number 05-0068). This kit contains a metal retainer bracket that attaches to the rear of the enclosure, 4 screws for attachment of this bracket, and a sealing gasket to insure that the panel mounted monitor provides a water tight seal when mounted to a panel.

The sealing gasket must first be attached to the enclosure. The gasket contains an adhesive on one side so that it remains in place on the enclosure. Remove the protective paper from the adhesive side of the gasket and slide the gasket over the back of the enclosure so that the adhesive side lines up with the back of the enclosure flange. Once in place, you can proceed to mount the monitor in the panel.

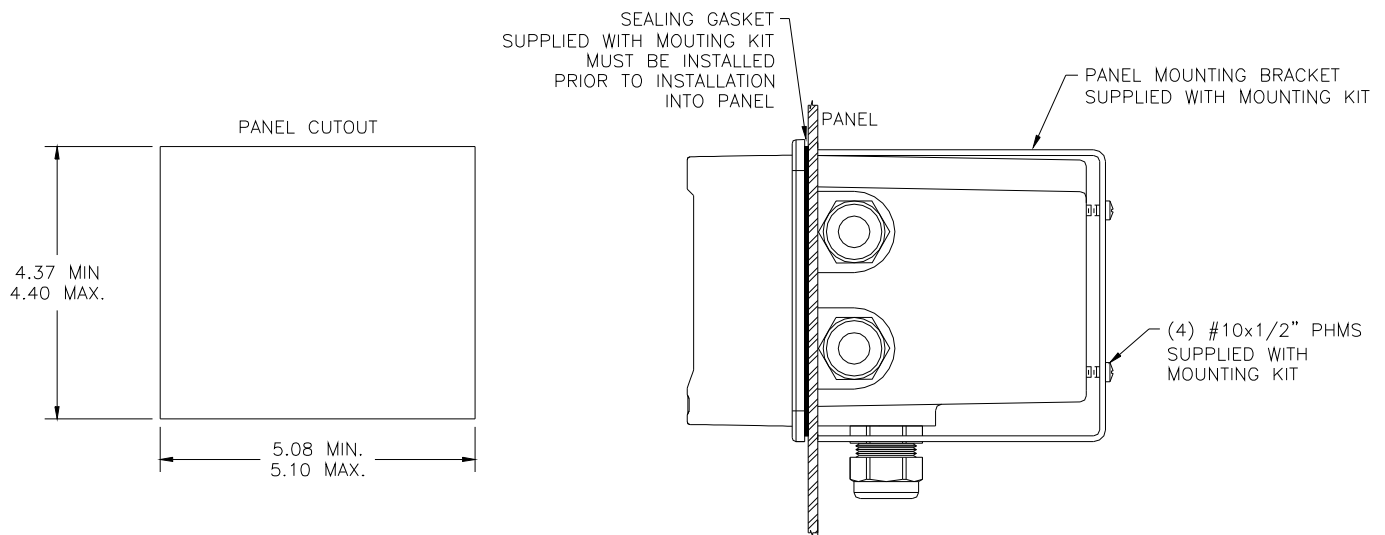

**Figure 5 - Panel Mount Installation**

## Part 3 – Sensor Mounting

### 3.1 General

Select a location within the maximum sensor cable length for mounting of the sensor. Locating the sensor within 25 ft. of the transmitter is generally preferred for ease of operation and calibration.

### 3.2 Submersion Mounting

Most applications for D.O. monitoring are done using a submersible sensor. This method can be used where flow is reasonably constant, and hydraulic head does not vary more than about 10 feet. Oxygen sensors can never be used in completely stagnant conditions. A flow velocity of at least 0.3 feet per second is normally required for measurement.

Submersible sensors are mounted to a 1" pipe using a standard 1" PVC thread by thread pipe coupling. The mounting pipe can be secured to standard 1½" or 2" pipe rail using a mounting bracket kit available from ATI (part number 00-0628) as shown in Figure 6 - Submersible Sensor Mounting.

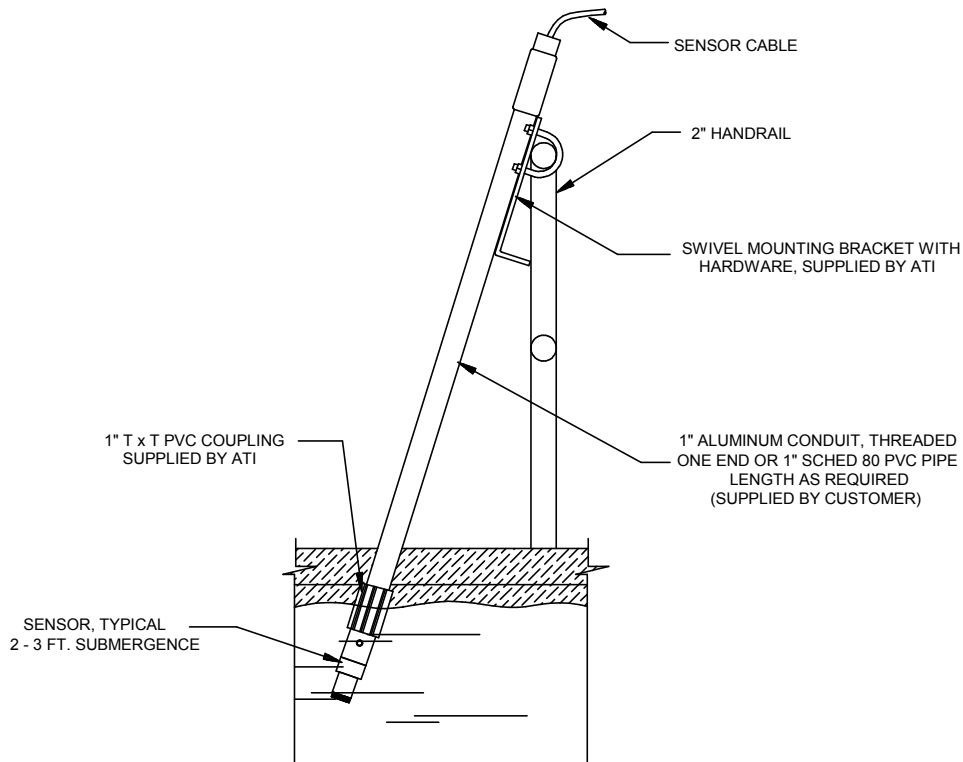
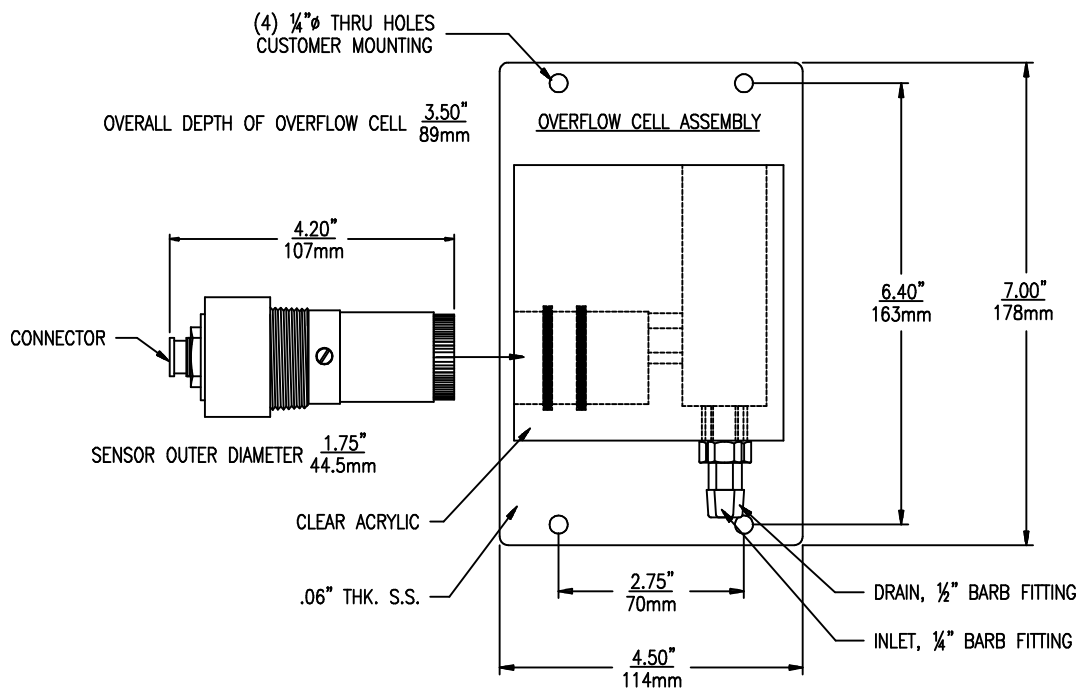

**Figure 6 - Submersible Sensor Mounting**

### 3.3 Flowcell Mounting

For applications requiring measurement in a flowing water line, a flowcell assembly and a flow-type sensor should be used. Two types of flowcell are available. Applications that allow an open flow system can best be satisfied using the 00-0043 constant-head flowcell. This flowcell is open to atmosphere and the drain is a gravity drain that must go to waste.

For applications where in-line measurement is required, flowcell no. (00-1522) should be used. This flowcell allows pressurized sample to flow to the sensor, but provision must be made for controlling the flow at 300-500 cc/min. Sample pressure can be variable provided pressure changes are relatively slow. Rapid pressure changes will cause a spike in the measured D.O. value.



**Figure 7 - Constant Head Flowcell Dimensions**

**3.4 Sealed Flowcell**

Applications where the sample inlet flow is well controlled can use a simpler sealed flowcell. Using this flowcell requires that flow be controlled externally to about 400 cc/min. Variable flow rate or variable pressure will cause unstable readings in this flowcell. ATI offers a special flow control element that can be used ahead of this flowcell on the incoming sample line. The flow control is part no. (55-0048). It will control the inlet flowrate at 400 cc/min. with inlet pressure variations from 5-150 PSIG. A 50 micron y-strainer ahead of the flow control element is recommended. The sealed flowcell provides a drain vent with check valve to avoid pulling a vacuum on the flow chamber.

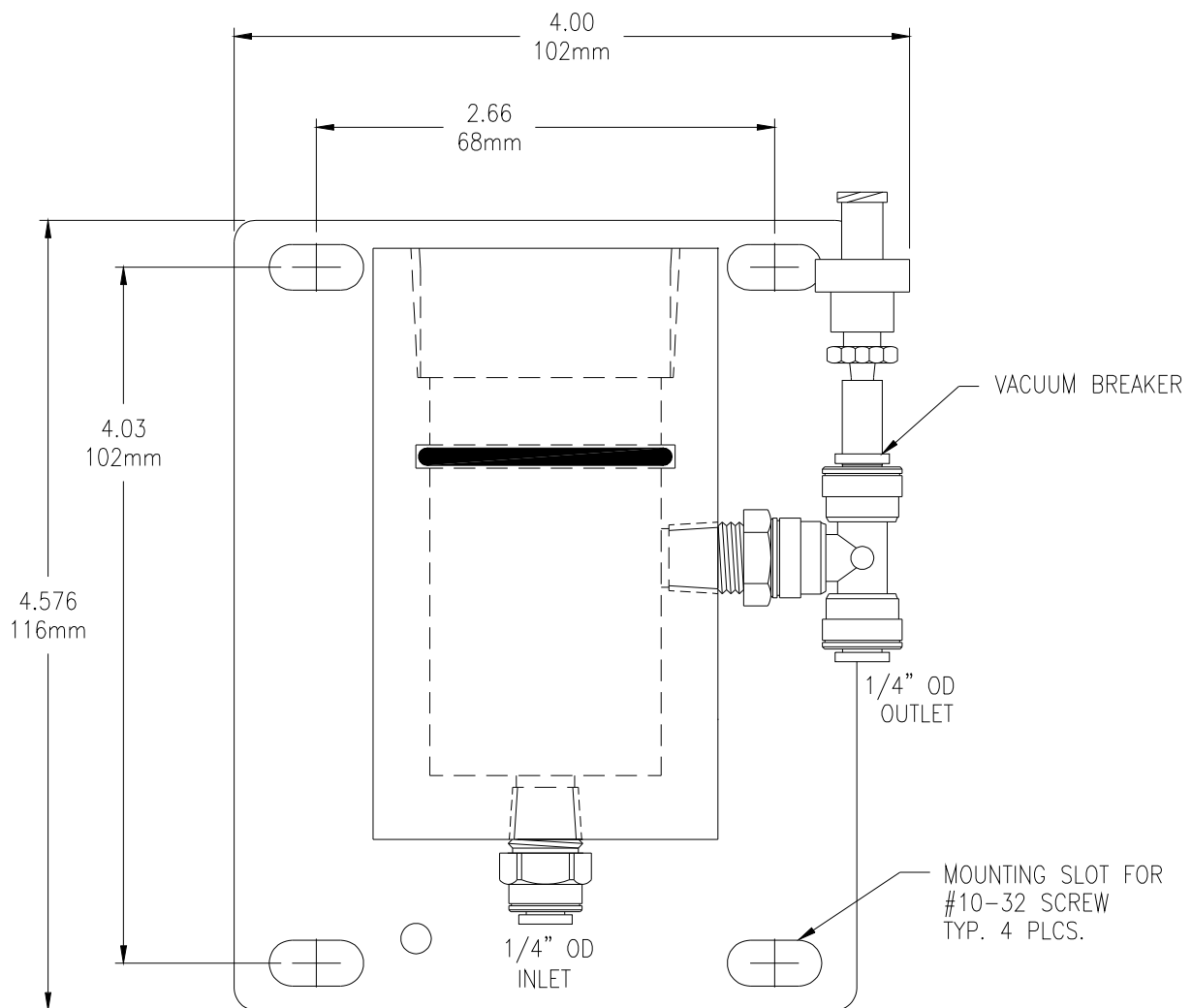

**Figure 8 - Sealed Flowcell Dimensions**

## Part 4 – Electrical Installation

---

### 4.1 General

The Q46 is powered in one of two ways, depending on the version purchased. The 12-24 VDC powered analyzer requires a customer supplied DC power supply. The 90-260 VAC version requires line power. Please verify the type of unit before connecting any power.

**WARNING: Do not connect AC line power to the DC version. Severe damage will result.**

#### Important Notes:

1. Use wiring practices that conform to national, state and local electrical codes. For proper safety as well as stable measuring performance, it is important that the earth ground connection be made to a solid ground point on TB7. The AC power supply in the transmitter contains a single 250mA slo-blo fuse (Wickmann #372-0250). The DC powered version contains a 250 mA fuse. The fuse **F1** is located adjacent to **TB7** and is easily replaceable.
2. Do NOT run sensor cables or instrument 4-20 mA output wiring in the same conduit that contains AC power wiring. AC power wiring should be run in a dedicated conduit to prevent electrical noise from coupling with the instrumentation signals.
3. This analyzer must be installed by specifically trained personnel in accordance with relevant local codes and instructions contained in this operating manual. Observe the analyzer's technical specifications and input ratings. Proper electrical disconnection means must be provided prior to the electrical power connected to this instrument, such as a circuit breaker - rated 250 VAC, 2 A minimum. If one line of the line power mains is not neutral, use a double-pole mains switch to disconnect the analyzer.



## 4.2 AC Powered Instrument Wiring

Verify the AC power supply requirement before installing. Also verify that power is fully disconnected before attempting to wire.

Q46 systems are supplied with 5 cable gland fittings for sealing cable entries.

Connect HOT, NEUTRAL, and GROUND to the matching designations on terminal strip **TB7**.

### **WARNING**

**Disconnect line power voltage BEFORE connecting line power wires to Terminal TB5 of the power supply. The power supply accepts only standard three-wire single phase power. The power supply is configured for 115 VAC or 230 VAC operation at the factory at time of order, and the power supply is labeled as such. Do NOT connect voltages other than the labeled requirement to the input.**

The analog outputs from the system are present at terminals TB1 and TB2. The loop-load limitation in this configuration is 450 Ohms maximum for output 1 and 1000 ohms maximum for output 2. Also note that these two outputs are completely isolated from each other to insure that ground loops do not result from the connection of both outputs to the same device such as a PLC or DCS.

A ribbon cable connects the power supply assembly with the microprocessor assembly located in the front section of the enclosure. This cable may be unplugged from the front section of the monitor if service is needed, but should normally be left in place during installation.

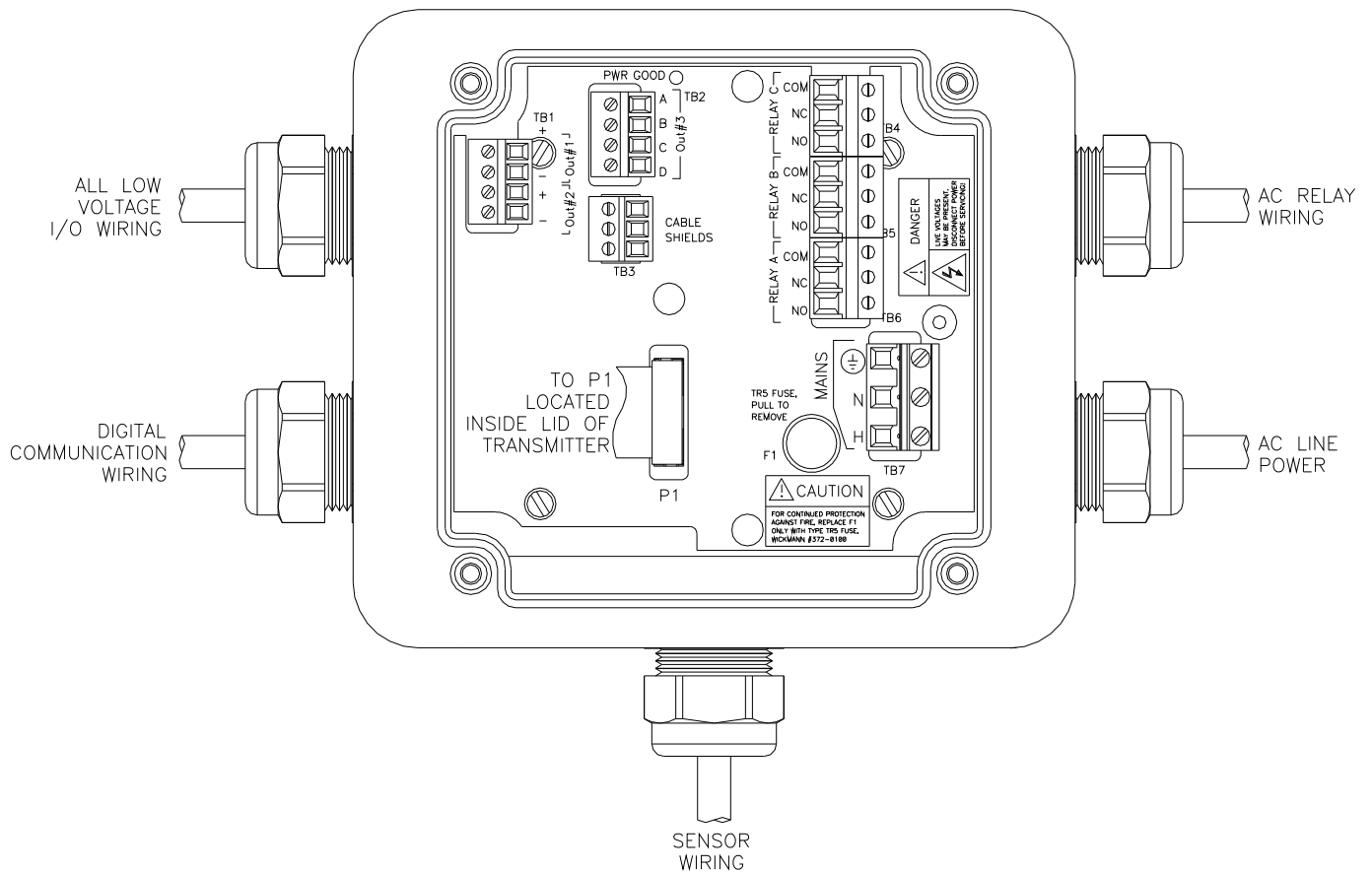

**Figure 9 - AC Power Connections**

The power strip, **TB5**, allows up to 12 AWG wire. A wire gauge of 16 AWG is recommended to allow for an easy pass-through into the M16 ports when wiring.

4.3 Relay Connection

Three SPDT relays are provided on the power supply board. None of the relay contacts are powered. The user must supply the proper power to the contacts. For applications that require the same switched operating voltage as the Q46 (115 or 230 V), power may be jumped from the power input terminals at **TB7**. Relay wiring is connected at **TB4**, **TB5**, and **TB6** as shown below. Note that the relay contact markings are shown in the NORMAL mode. Programming a relay for “Failsafe” operation reverses the NO and NC positions in this diagram (Figure 10 - Relay Contacts).

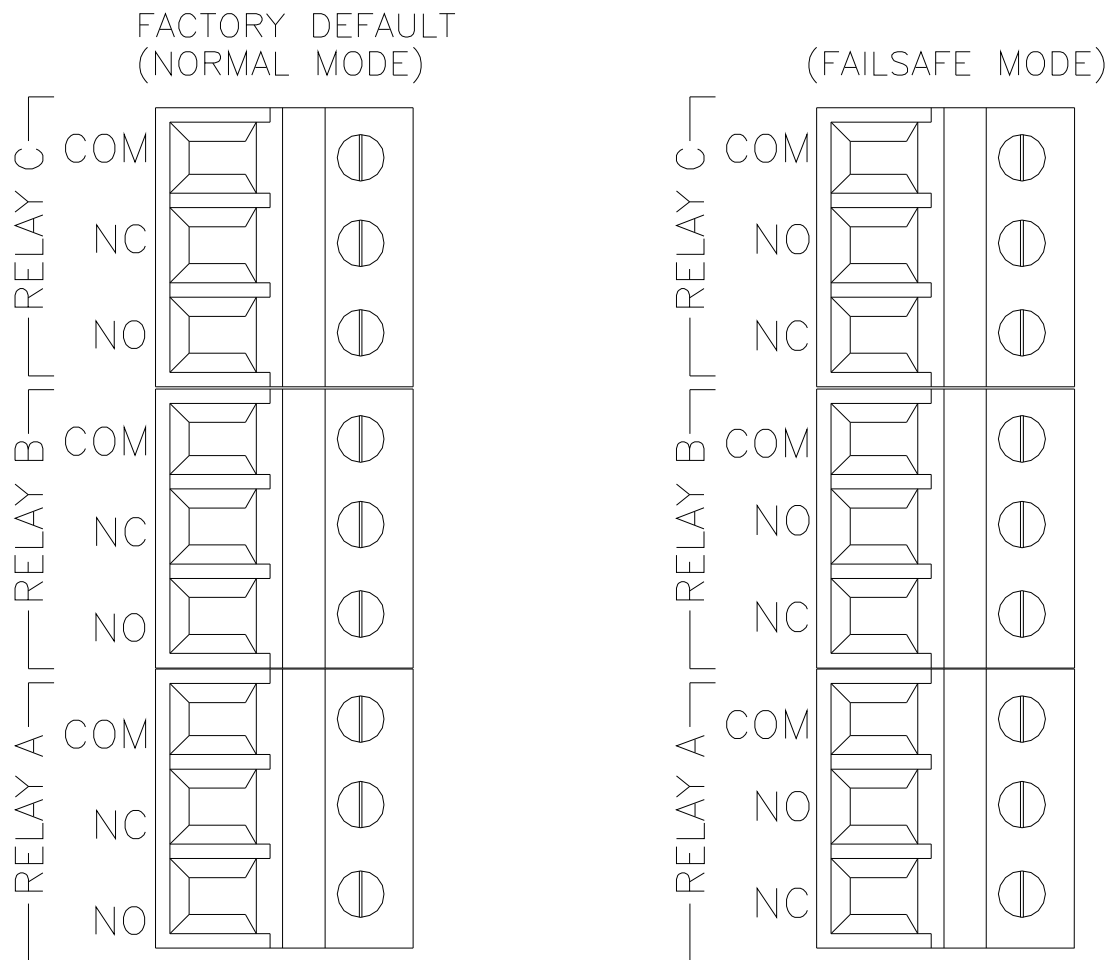
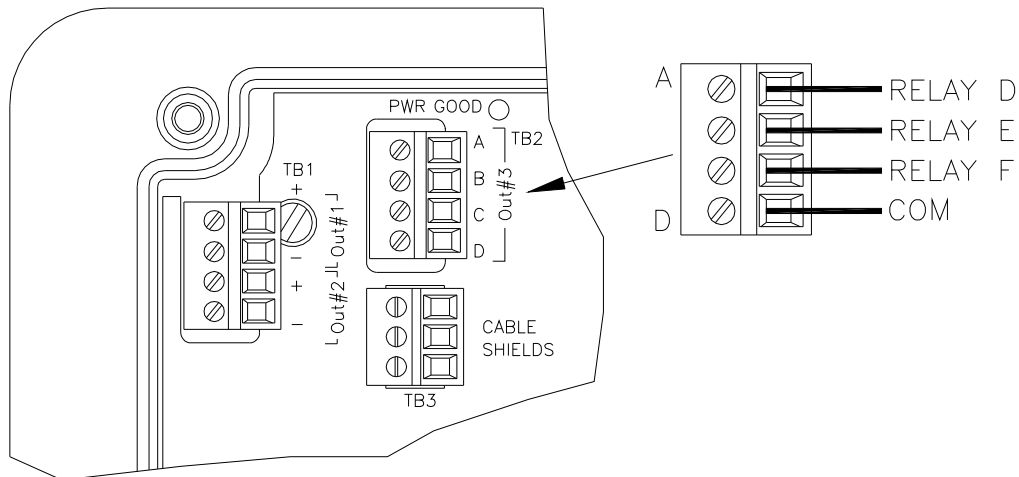

Figure 10 - Relay Contacts

### 4.4 Optional Output/Relay Connection

**TB2**, is used to connect to the optional 3-relay card (Figure 11) **OR** the optional third analog output **Out#3**, (Error! Reference source not found.). The Q46 can be configured for only one of these optional features, and the hardware for either option must be factory installed. Note that the optional 3 relays are for switching **LOW POWER DC ONLY**.



**Figure 11 - Optional Low Power Relay Wiring**

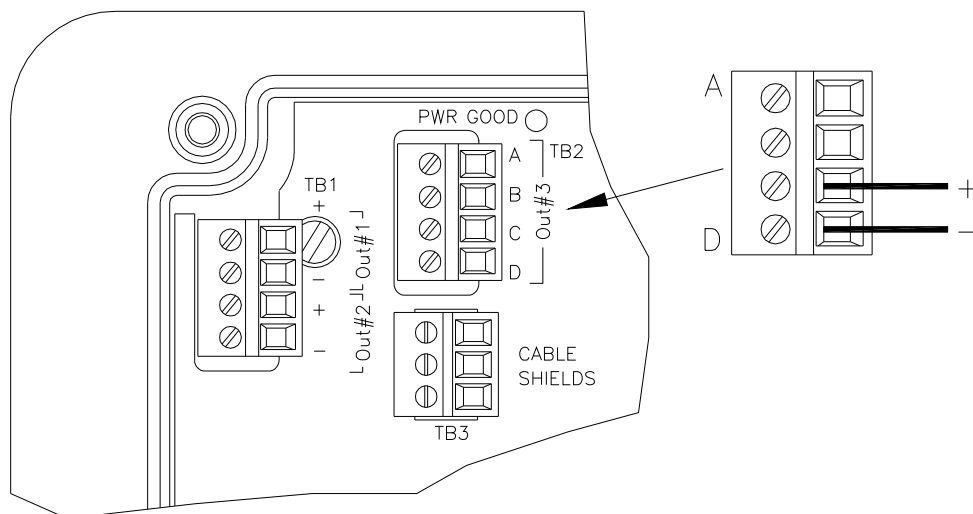

**Figure 12 - Optional 3rd Analog Output Wiring**

**4.5 Sensor Wiring**

The sensor cable can be quickly connected to the Q46 terminal strip by matching the wire colors on the cable to the color designations on the label in the monitor. A junction box is also available to provide a break point for long sensor cable runs. Route signal cable away from AC power lines, adjustable frequency drives, motors, or other noisy electrical signal lines. Do not run sensor or signal cables in conduit that contains AC power lines or motor leads.

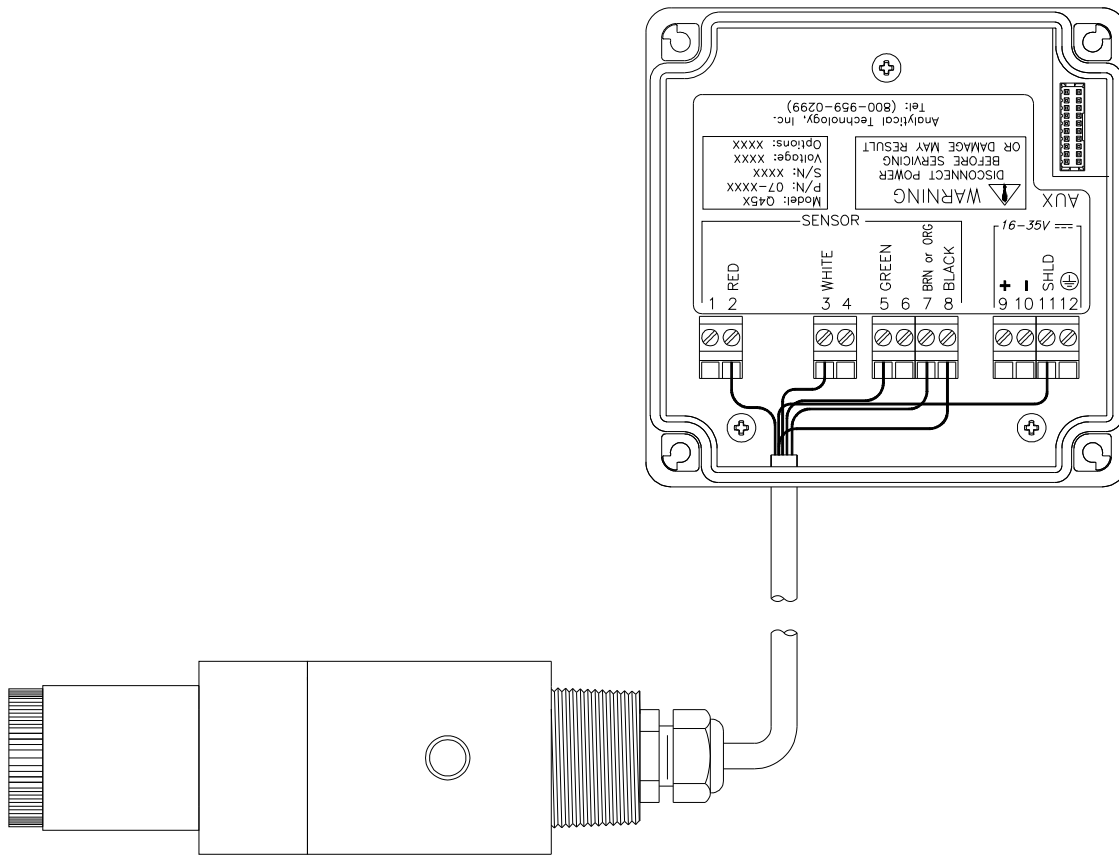
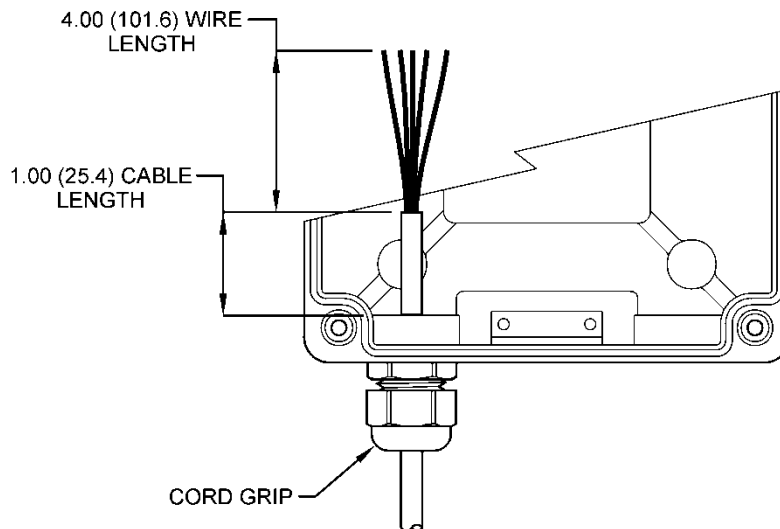

**Figure 13 - Submersible Sensor Connection**

#### 4.6 Direct Sensor Connection

The sensor cable can be routed into the enclosure through one of cord-grips supplied with the unit. Routing sensor wiring through conduit is only recommended if a junction box is to be used. Some loose cable is needed near the installation point so that the sensor can be inserted and removed easily from the flowcell.

Cord-grips used for sealing the cable should be snugly tightened after electrical connections have been made to prevent moisture incursion. When stripping cables, leave adequate length for connections in the analyzer enclosure as shown below. The standard 25 ft. sensor cable normally supplied with the system is already stripped and ready for wiring. This cable can be cut to a shorter length if desired to remove extra cable in a given installation. Do not cut the cable so short as to make installation and removal of the sensor difficult.



**Figure 14 - Sensor Cable Preparation**

4.7 Junction Box Connection

For installations where the sensor is to be located more than 25 feet from the monitor (max. 100 feet), a junction box must be used. The junction box is shown in Figure 15 - Junction Box Interconnect Wiring, and is supplied with a ½" conduit hub on one end and a sensor cable gland on the other end.

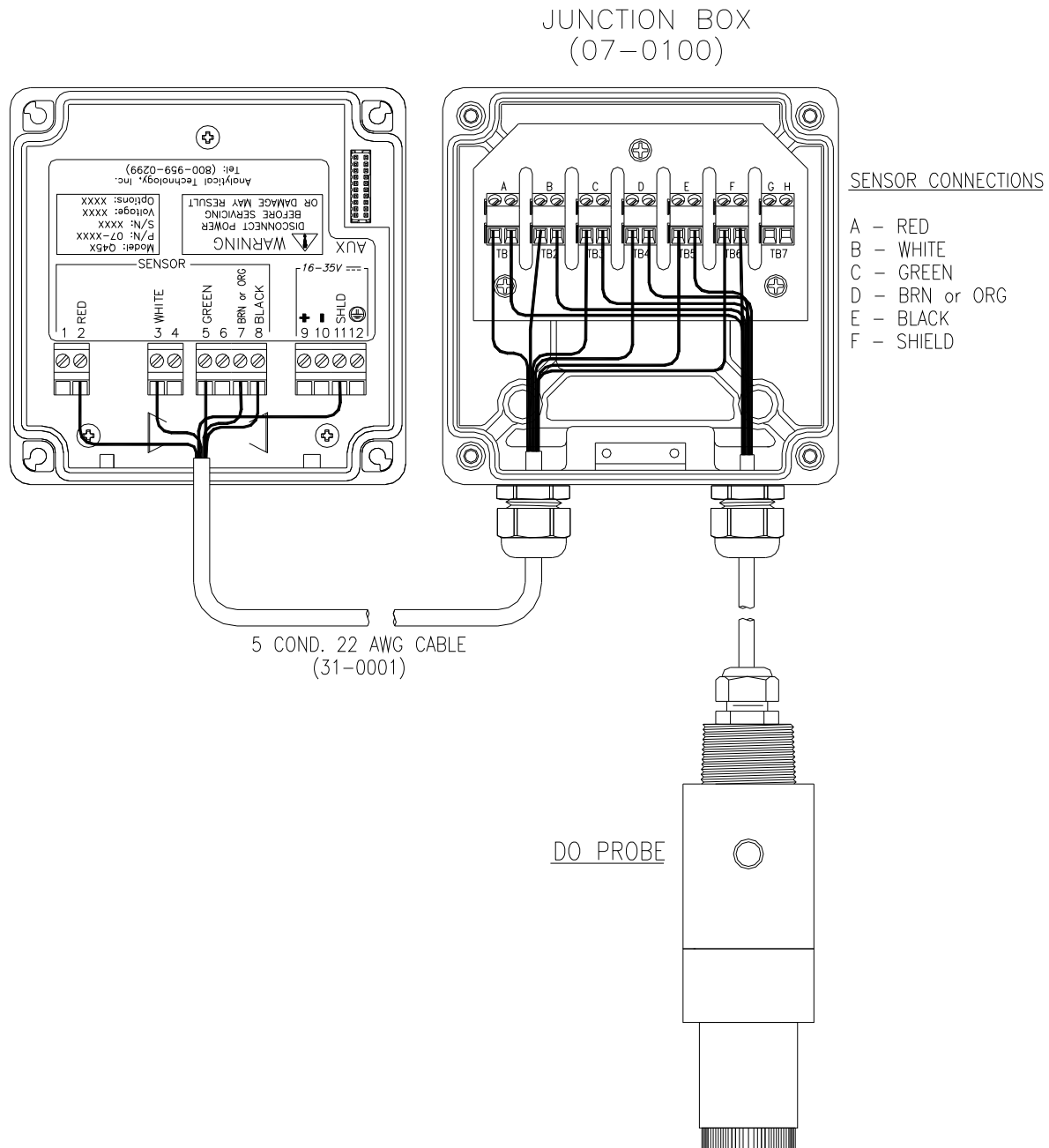

Figure 15 - Junction Box Interconnect Wiring

# Part 5 – Sensor Assembly

## 5.1 Oxygen Sensor Preparation

The oxygen sensor supplied with the Q46D is shipped dry. It will not operate until it is prepared by adding electrolyte and a membrane. Preparation of the sensor for operation must be done carefully. The procedure should be done by a qualified technician, and it should only be done when the system is ready for operation. Until then, it is best to leave the sensor in the condition in which it is received.

Submersible oxygen sensors are made up of two separate parts, a submersion holder that also contains the temperature compensating element and a sensing module. The sensing module screws into the holder, with an o-ring providing a water tight connection. Figure 16 - Submersible Sensor Assembly below shows the assembly.

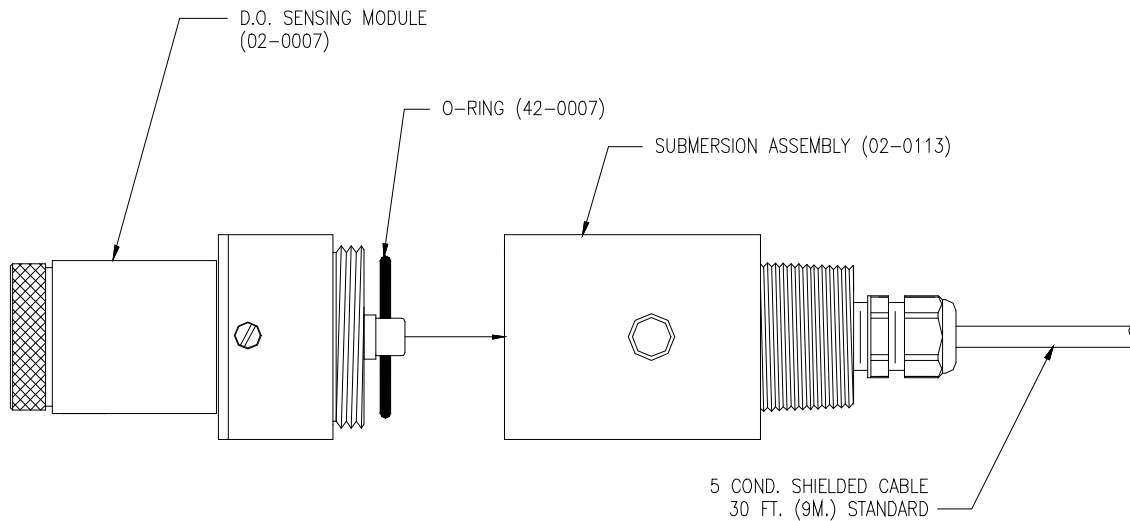

**Figure 16 - Submersible Sensor Assembly**

Sensing modules contain the main measuring components, and are the main component requiring service. Figure 17 - Submersible Sensor Module Exploded View below shows an exploded view of the D.O. sensing module.



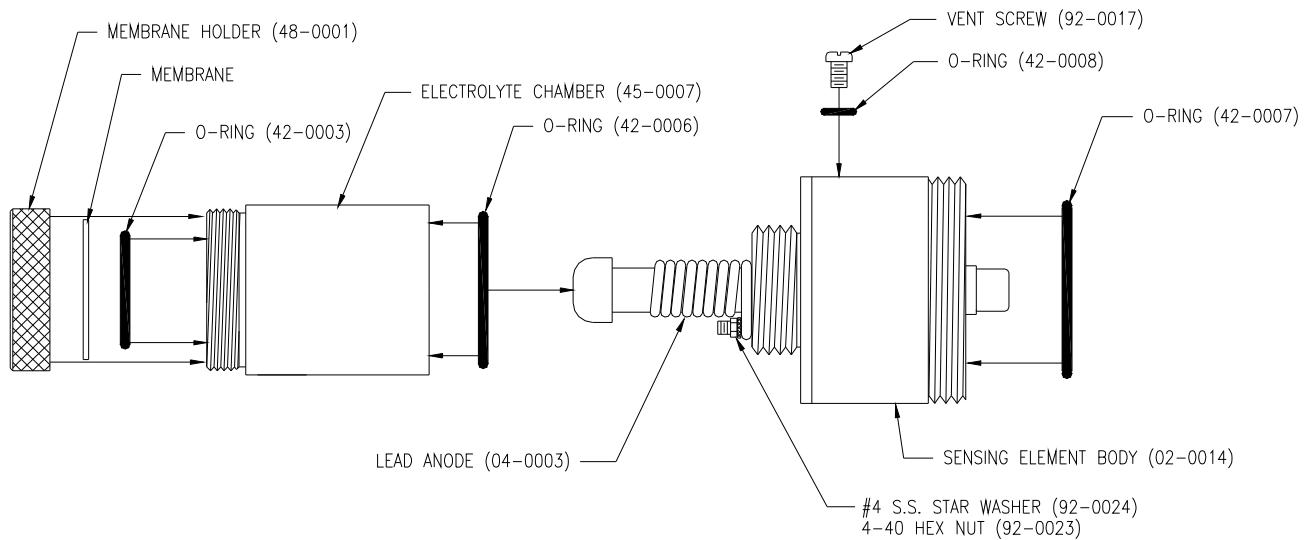

**Figure 17 - Submersible Sensor Module Exploded View**

Follow the procedure below to prepare the D.O. sensor module for operation:

1. Unscrew the electrolyte chamber from the assembled sensor and also remove the vent screw from the side of the sensor body.
2. Remove the front nut from the bottom of the chamber and discard the protective membrane. O-rings are contained in grooves on both the bottom and top of the chamber. Be sure that these o-rings remain in place.
3. From the package of membranes (either 2-mil or 5 mil) supplied with the sensor, place a new membrane into the front nut, holding the membrane by its edge to avoid fingerprint oil from contaminating the membrane. **The membrane is clear and is separated from other membranes by a light blue paper spacer.**
4. Screw the front nut on to the chamber until you feel the o-ring compress. Hand tight compression is all that is needed. Do not use tools to tighten. The membrane should be flat across the bottom of the chamber without wrinkles.
5. Fill the chamber with electrolyte until the level reaches the bottom of the internal threads.

6. Slowly screw the chamber onto the sensor body. A small amount of electrolyte will run out of the hole from which the vent screw was removed. Place a paper towel around the sensor to absorb the electrolyte overflow. The electrolyte is harmless and will not irritate skin. Tighten the chamber until the o-ring at the top of the chamber is compressed. Once again, do not use tools to tighten.
7. Shake excess electrolyte from the vent hole on the side of the sensor and replace the vent screw.

The sensor is now ready for operation. The membrane should be stretched tightly across the tip of the sensor.

**CAUTION:** When handling the assembled sensor, do not set the sensor on its tip or damage to the membrane will result. Severe impacts on the tip of the sensor from dropping or other misuse may cause permanent damage to the sensor.

## 5.2 Flow Type D.O. Sensor

The D.O. sensor designed for use in flow applications is similar in construction to the sensing module described above. The method for sensor preparation is basically the same as described in section 5.1.

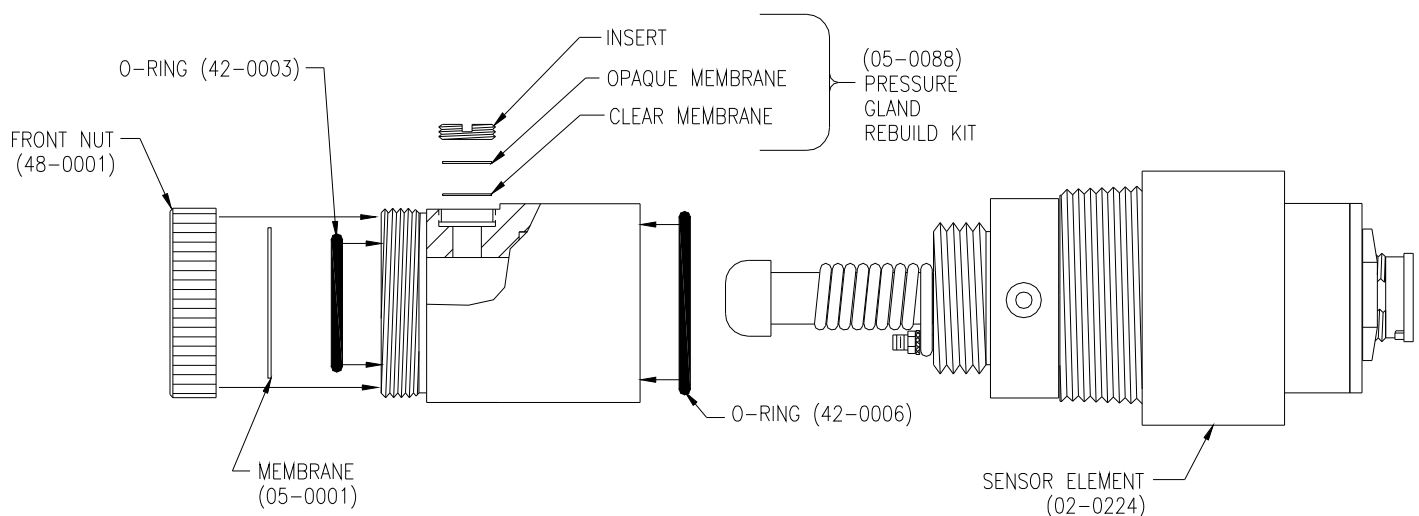

**Figure 18 - Flow Type D.O. Sensor Assembly**

# Part 6 – Configuration

## 6.1 User Interface

The user interface for the Q46 Series instrument consists of a custom display and a membrane keypad. All functions are accessed from this user interface (no internal jumpers, pots, etc.).

When power is first applied, you may notice that the display does not come on immediately. This is normal. There is a 5 second start routine that runs before the display illuminates. In addition, you will notice an occasional “flicker” of the display, occurring about twice an hour. This is the result of a display processor refresh program that insures long-term display integrity, and will always occur during normal operation of the instrument.

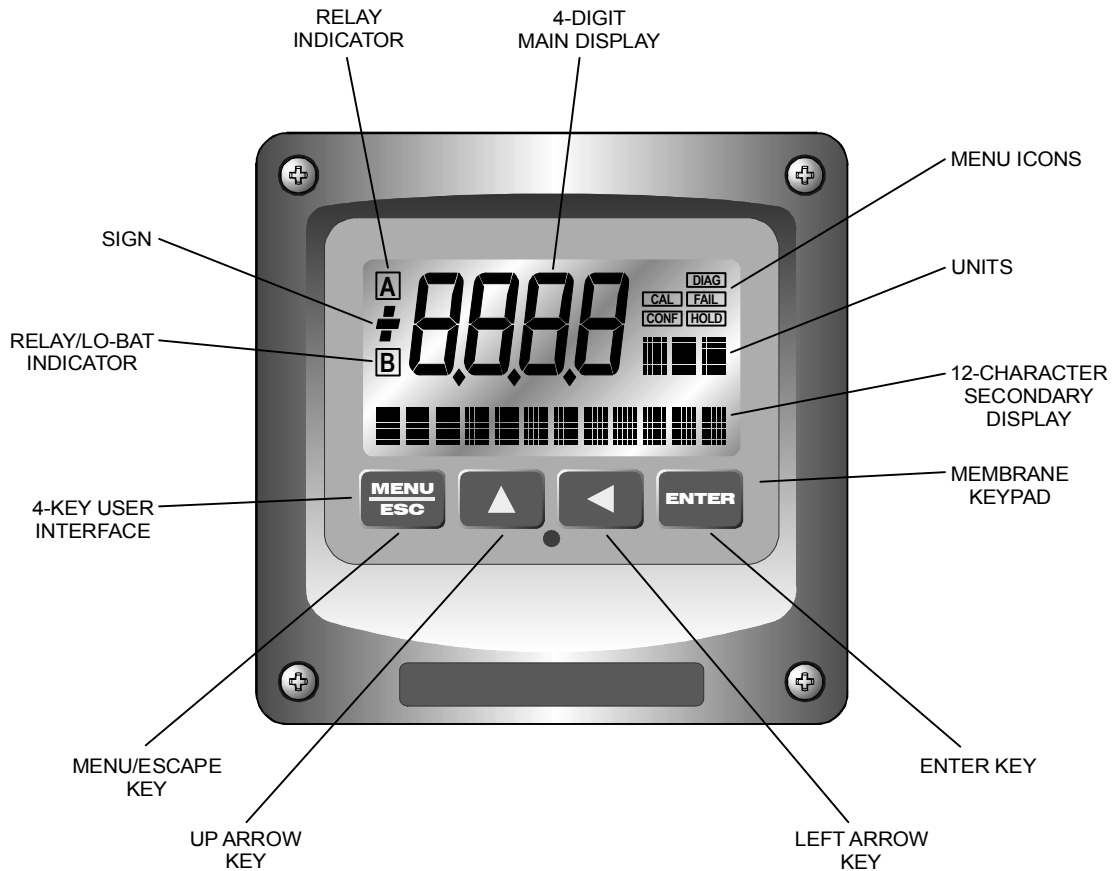

**Figure 19 - User Interface**

## 6.11 Keys

All user configurations occur through the use of four membrane keys. These keys are used as follows:

- MENU/ESC** To scroll through the menu section headers or to escape from anywhere in software. The escape sequence allows the user to back out of any changes in a logical manner. Using the escape key aborts all changes to the current screen and backs the user out one level in the software tree. The manual will refer to this key as either MENU or ESC, depending upon its particular function. In the battery-powered version of the Q46, this is also the ON button.
- UP (arrow)** To scroll through individual list or display items and to change number values.
- LEFT (arrow)** To move the cursor from right to left during changes to a number value.
- ENTER** To select a menu section or list item for change and to store any change.

## 6.12 Display

The large custom display provides clear information for general measurement use and user configuration. There are three main areas of the display: the main parameter display, the secondary message line, and the icon area.

**Main Parameter** During normal operation, the main parameter display indicates the present process input with sign and units. This main display may be configured to display any of the main measurements that the system provides. During configuration, this area displays other useful set-up information to the user.

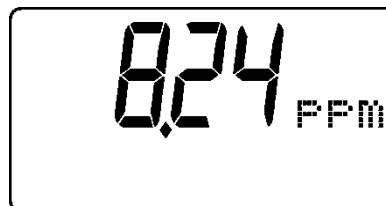

**Lower Line**

During normal operation, the lower line of the display indicates user-selected secondary measurements that the system is making. This also includes calibration data from the last calibration sequence and the transmitter model number and software version. During configuration, the lower line displays menu items and set-up prompts to the user. Finally, the lower line will display error messages when necessary. For a description of all display messages, refer to Section 10.31.

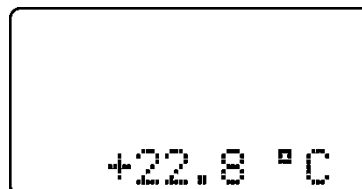
**Icon Area**

The icon area contains display icons that assist the user in set-up and indicate important states of system functions. The CAL, CONFIG, and DIAG icons are used to tell the user what branch of the software tree the user is in while scrolling through the menu items. This improves software map navigation dramatically. Upon entry into a menu, the title is displayed (such as CAL), and then the title disappears to make way for the actual menu item. However, the icon stays on.

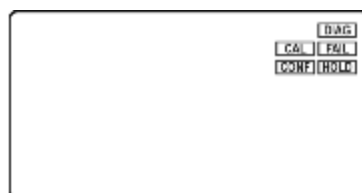
**HOLD**

The HOLD icon indicates that the current output of the transmitter has been put into output hold. In this case, the output is locked to the last input value measured when the HOLD function was entered. HOLD values are retained even if the unit power is cycled.

**FAIL**

The FAIL icon indicates that the system diagnostic function has detected a problem that requires immediate attention. This icon is automatically cleared once the problem has been resolved.

**Relay Area A/B/C**

The relay area contains two icons that indicate the state of the system relays. Relay C is normally configured for FAIL indication, so it is only displayed on the lower MEASURE display line.

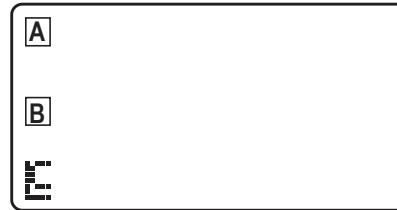
**6.2 Software**

The software of the Q46D is organized in an easy to follow menu-based system. All user settings are organized under five menu sections: Measure, Calibration [CAL], Configuration [CONFIG], Control [CONTROL] and Diagnostics [DIAG].

**Note: The default Measure Menu is display-only and has no menu icon.**

**6.21 Software Navigation**

Within the CAL, CONFIG, CONTROL, and DIAG menu sections is a list of selectable items. Once a menu section (such as CONFIG) has been selected with the MENU key, the user can access the item list in this section by pressing either the ENTER key or the UP arrow key. The list items can then be scrolled through using the UP arrow key. Once the last item is reached, the list wraps around and the first list item is shown again. The items in the menu sections are organized such that more frequently used functions are first, while more permanent function settings are later in the list. See Figure 20 - Software Map for a visual description of the software.

Each list item allows a change to a stored system variable. List items are designed in one of two forms: simple single variable, or multiple variable sequences. In the single variable format, the user can quickly modify one parameter - for example, changing temperature display units from °F to °C. In the multiple variable sequence, variables are changed as the result of some process. For example, the calibration of oxygen generally requires more than one piece of information to be entered. The majority of the menu items in the software consist of the single variable format type.

Any data that may be changed will be flashing. This flashing indicates user entry mode and is initiated by pressing the ENTER key. The UP arrow key will increase a flashing digit from 0 to 9. The LEFT arrow key moves the flashing digit from right to left. Once the change has been completed, pressing ENTER again stores the variable and stops the flashing. Pressing ESC aborts the change and also exits user entry mode.

The starting (default) screen is always the Measure Menu. The UP arrow key is used to select the desired display. From anywhere in this section the user can press the MENU key to select one of the four Menu Sections.

The UP arrow icon next to all list items on the display is a reminder to scroll through the list using the UP arrow key.

To select a list item for modification, first select the proper menu with the MENU key. Scroll to the list item with the UP arrow key and then press the ENTER key. This tells the system that the user wishes to perform a change on that item. For single item type screens, once the user presses the ENTER key, part or all of the variable will begin to flash, indicating that the user may modify that variable using the arrow keys. However, if the instrument is locked, the transmitter will display the message **Locked!** and will not enter user entry mode. The instrument must be unlocked by entering the proper code value to allow authorized changes to user entered values. Once the variable has been reset, pressing the ENTER key again causes the change to be stored and the flashing to stop. The message **Accepted!** will be displayed if the change is within pre-defined variable limits. If the user decides not to modify the value after it has already been partially changed, pressing the ESC key aborts the modification and returns the entry to its original stored value.

In a menu item which is a multiple variable sequence type, once the ENTER key is pressed there may be several prompts and sequences that are run to complete the modification. The ESC key can always be used to abort the sequence without changing any stored variables.

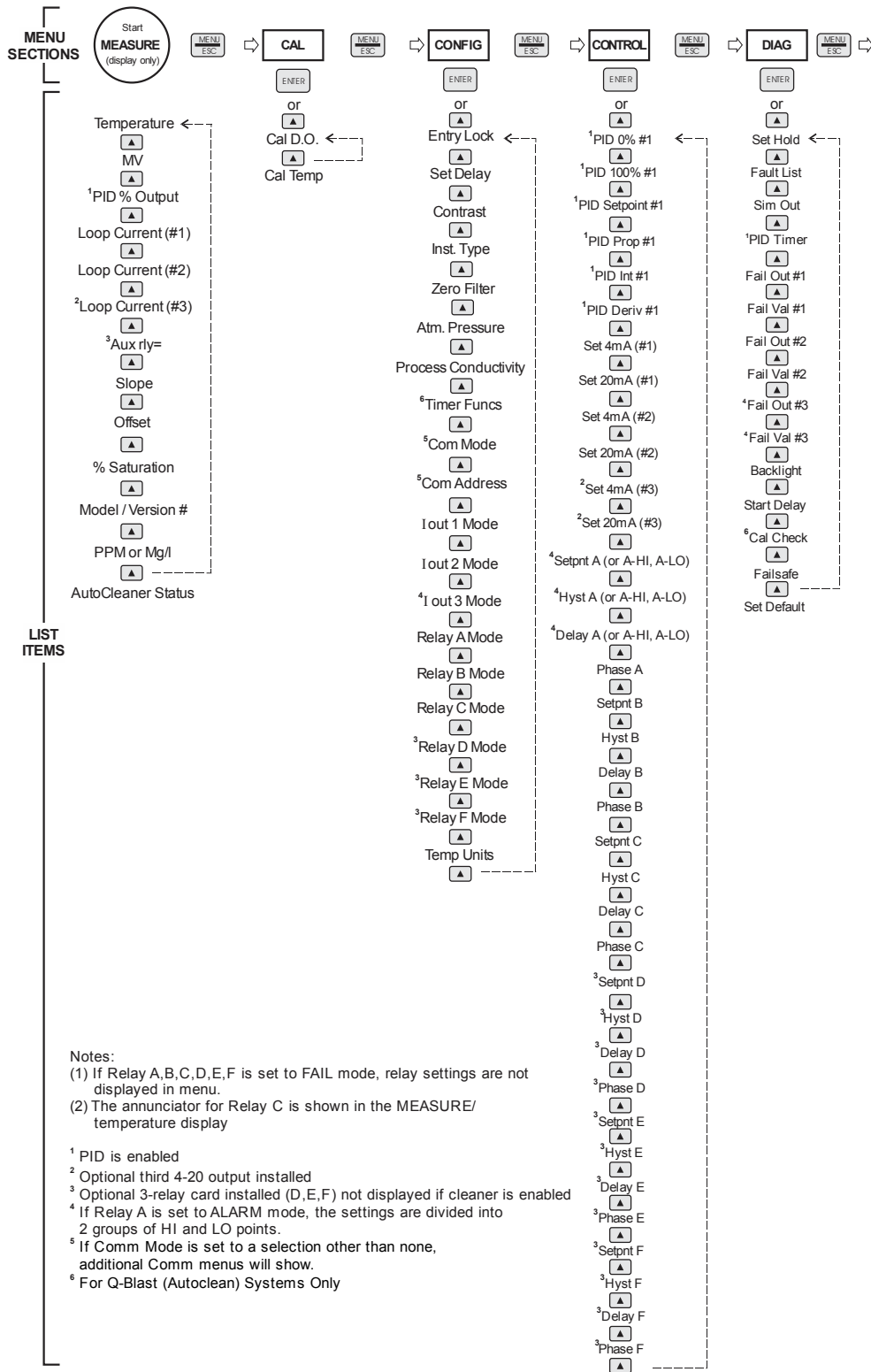

Figure 20 - Software Map



## 6.22 Measure Menu [MEASURE]

The default menu for the system is the display-only menu MEASURE. This menu is a display-only measurement menu, and has no changeable list items. When left alone, the instrument will automatically return to this menu after approximately 30 minutes. While in the default menu, the UP arrow allows the user to scroll through the secondary variables on the lower line of the display. A brief description of the fields in the basic transmitter version is as follows:

### TRANSMITTER MEAS SCREENS:

<b>25.7°</b>	Temperature display. Can be displayed in °C or °F, depending on user selection. A small “m” on the left side of the screen indicates the transmitter has automatically jumped to a manual 25C setting due to a failure with the temperature signal input.
<b>320 mV</b>	Raw sensor signal. Useful for diagnosing problems.
<b>100% 20.00 mA</b>	PID Status screen (if enabled.) Shows the present controller output level on left, and actual transmitter current on the right. The controller can be placed in manual while viewing this screen by pressing and holding the ENTER key for 5 seconds until a small flashing “m” appears on the screen. At that point the controller output can be adjusted up or down using the UP and LEFT arrow keys. To return to automatic operation, press and hold the ENTER key for 5 seconds and the “M” will disappear.
<b>#1 4.00 mA</b>	Analyzer output current # 1.
<b>#2 12.00 mA</b>	Analyzer output current # 2.
<b>#3 20.00 mA</b>	Analyzer output current # 3 (if option included.)
<b>Aux relay= D,E,F</b>	Auxiliary relay annunciators (if option included.)
<b>Slope = 100%</b>	Sensor output response vs. ideal calibration. This value updates after each calibration. As the sensor ages, the slope reading will decay indicating sensor aging. Useful for resolving sensor problems.

<b>Offset = 0.0 mV</b>	Sensor output signal at a zero ppm input. This value updates after a zero-calibration has been performed. Useful for resolving sensor problems.
<b>0.00 PPM</b>	D.O. Reading in PPM (or mg/L if selected under Instr Type)
<b>% Saturation</b>	The most common display of D.O. in water is either PPM or mg/L units. However, the same PPM value at different water temperatures can represent quite different concentrations of oxygen in terms of the percent of saturation. This display simply indicates the % of oxygen saturation represented by the current PPM or mg/L display.
<b>Q46D v4.02</b>	Transmitter software version number.
<b>Tcyc 24.0 hr</b>	Automatic sensor cleaning frequency (displayed only when enabled by programming relay B for CIn1 or CIn2).

**Note: A display test (all segments ON) can be actuated by pressing and holding the ENTER key while viewing the model/version number on the lower line of the display.**

The MEASURE screens are intended to be used as a very quick means of looking up critical values during operation or troubleshooting.

### 6.23 Calibration Menu [CAL]

The calibration menu contains items for frequent calibration of user parameters. There are two items in this list: Cal D.O. and Cal Temp.

<b>Cal D.O.</b>	The oxygen calibration function allows the user to adjust the transmitter span reading to match a reference solution, or to set the sensor zero point. See Part 7 - Calibration for more details.
<b>Cal Temp</b>	The temperature calibration function allows the user to adjust the offset of the temperature response by a small factor of $\pm 5^{\circ}\text{C}$ . The temperature input is factory calibrated to very high accuracy. However, long cable lengths and junction boxes may degrade the accuracy of the temperature measurement in some extreme situations. Therefore, this feature is provided as an adjustment. See Part 7 - Calibration for more details.

## 6.24 Configuration Menu [CONFIG]

The Configuration Menu contains all of the general user settings:

- Entry Lock** This function allows the user to lock out unauthorized tampering with instrument settings. All settings may be viewed while the instrument is locked, but they cannot be modified. The Entry Lock feature is a toggle-type setting; that is, entering the correct code will lock the transmitter and entering the correct code again will unlock it. The code is preset at a fixed value. Press ENTER to initiate user entry mode and the first digit will flash. Use arrow keys to modify value. **See Spare Parts List at the end of this manual for the Q46D lock/unlock code.** Press ENTER to toggle lock setting once code is correct. Incorrect codes do not change state of lock condition.
- Set Delay** The delay function sets the amount of damping on the instrument. This function allows the user to apply a first order time delay function to the oxygen measurements being made. Both the display and the output value are affected by the degree of damping. Functions such as calibration are not affected by this parameter. The calibration routines contain their own filtering and stability monitoring functions to minimize the calibration timing. Press ENTER to initiate user entry mode, and the value will flash. Use the arrow keys to modify value; range is 0.1 to 9.9 minutes. Press ENTER to store the new value.
- Contrast** This function sets the contrast level for the display. The custom display is designed with a wide temperature range and contains an LED back light so that the display is can be seen in the dark.
- Press ENTER to initiate user entry mode, and the value will flash. Use arrow keys to modify the value; range is 0 to 8 (0 being lightest). Press ENTER to update and store the new value.
- Instr Type** This function allows the user to change the type of measurement to be displayed in the primary display area. The user may select “**1 PPM**”, “**2 mg/L**”, or “**3 %Sat**”. There is not a great deal of difference between type 1 and 2 settings as PPM and mg/L measurement units are pretty close to the same.

Programming for type 3 percent saturation changes the measured parameter to read a dissolved oxygen value that represents the percent of oxygen saturation at a given temperature. When this unit of measurement is selected, the main analog output and all alarm and control functions will relate to this measurement. While a PPM measurement is displayed on the lower line, it is no longer the primary variable being measured by the system. Press ENTER to initiate user entry mode, and the selected value will flash. Use the UP arrow key to modify the desired display value. Press ENTER to store the new value.

**Zero Filter**

The Q46D allows the user to program a value near zero below which the monitor will read zero. Because sensors rarely have a perfect zero stability, this zero filter eliminates occasional displays of numbers that are not meaningful. For instance, setting a zero filter at 0.03 PPM D.O. will cause any measured values of 0.01 or 0.02 PPM to be displayed as 0.00 PPM.

**Atm Pres**

The Q46D instrument utilizes the atmospheric pressure value as an input for the calculation of a theoretical ppm value during a saturation calibration. The input default units are inHg (inches Mercury) since these units are easy to obtain from most local weather services or from the general chart located in page 64 of this manual. This value is only required to be entered during initial installation – it does not need to be modified at every calibration. Press ENTER to initiate user entry mode and the entire value will flash. Use the arrow keys to modify the value; range is 20.00 to 31.50 inHg.

A reference table is provided in Section 9 to convert to inHg from several other common air pressure units. Press ENTER to store the new value.

**Proc Cond**

The Q46D instrument also utilizes the process conductivity value as an input for the calculation of a theoretical ppm value during a saturation calibration. This value is only required to be entered during initial installation - it does not need to be modified at every calibration. Press ENTER to initiate user entry mode and the value will flash. Use the arrow keys to modify the value; range is 0.00 to 76.00 mS/cm. Press ENTER to store the new value.

Note: If the user will not be changing solution conductivity dramatically during the calibration process, leave a default setting of 00.50 mS/cm. For ultrapure water applications, set this value to 0.00. For sea water applications, set this value to 53.00.

**Timer Funcs**

Enables the Autocleaner Logic on Relays D, E, and F. When enabled, these auxiliary relays control the remote autocleaner enclosure. The autocleaner enclosure provides automatic sensor cleaning using a highly effective air-blast system (Q-Blast) that is self contained in the AC enclosure. When enabled the D, E, and F relay settings are not displayed in the CONFIG or CNTR menus. This can also be used to control a customer supplied external air delivery source.

**Com Mode**

Sets digital communication mode of analyzer. Optional digital communication card must be plugged into the power supply slot for this function to work. Press ENTER to initiate user entry mode, and the entire value will flash. Use the UP arrow key to modify the desired value; selections include 1- None, 2- P-DP for Profibus DP, 3 – Modbus, 4 – Ethernet IP. Press ENTER to store the new value.

**Com Address**

Sets bus address for digital communication mode of analyzer. Optional digital communication card must be plugged into the power supply slot for this function to work.

Press ENTER to initiate user entry mode, and the entire value will flash. Use the UP arrow key to modify the desired value. Range is 1-125. Press ENTER to store the new value.

**lout#1 Mode**

This function sets analog output #1 to either track PPM or mg/L oxygen (default), % Saturation, or enables the PID controller to operate on the oxygen input in either PPM, mg/L, or % Saturation. Press ENTER to initiate user entry mode, and the entire value will flash. Use the UP arrow key to modify the desired value; selections include 1- for oxygen tracking or 2-PID for oxygen PID control. Press ENTER to store the new value.

**\*Iout#2 Mode** This function sets analog output #2 for either temperature (default) or oxygen. Press ENTER to initiate user entry mode, and the entire value will flash. Use the UP arrow key to modify the desired value; selections include 1-C/F for temperature, or 2-ppm for oxygen, or 3-% Saturation. Press ENTER to store the new value.

**\*Iout#3 Mode** **OPTIONAL.** This function sets analog output #3 for either temperature (default) or D.O. Press ENTER to initiate user entry mode, and the entire value will flash. Use the UP arrow key to modify the desired value; selections include 1-C/F for temperature or 2-ppm for oxygen. Press ENTER to store the new value.

**\*Rly A Mode** Relay A can be used in three different ways: as a setpoint control, as a fail alarm, or as a HI-LO alarm band. The three settings for Rly A Mode are **CON**, **FAIL** and **AL**.

The **CON** setting enables normal control operation for Relay A, with settings for setpoint, hysteresis, delay and phasing appearing in the CONFIG menu automatically. See Figure 21 - Control Relay Example, Hysteresis & Phase Options for further details.

The **FAIL** setting enables the fail alarm mode for Relay A. Relay A will then trip on any condition that causes the FAIL icon to be displayed on the LCD. Using this mode allows the User to send alarm indications to other remote devices.

The **AL** setting allows two setpoints to be selected for the same relay, producing a HI-LO alarm band. In this mode, Relay A will trip inside or outside of the band, depending upon the Phase selected. See Figure 22 - Alarm Relay Example for further details.

**\*Relay B Mode** The settings for Relay B Mode are identical to the corresponding modes on Relay A.

**Relay C Mode** Relay C can be used in two ways: as a setpoint control, or as an alarm. The two settings for Relay C Mode are **CON** and **FAIL**.

The **CON** setting enables normal setpoint operation for Relay B/C. Relay B/C then operates identically to Relay A, with settings for setpoint, hysteresis, delay and phasing

appearing in the CONFIG menu automatically. See Figure 21 for details.

The **FAIL** setting enables the fail alarm mode for Relay B/C. Relay B/C will then trip on any condition that causes the FAIL icon to be displayed on the LCD. Note that the Relay C indicator shows up only on the lower screen of the display next to the temperature reading. This is because the default setting for relay C is the **FAIL** setting. Using this mode allows the User to send alarm indications to other remote devices. See Figure 22 for details.

**\*Relay D Mode**  
**\*Relay E Mode**  
**\*Relay F Mode**

**OPTIONAL.** Relays D, E, and F can be used in two ways: as a setpoint control, or as an alarm. The two settings for Relays D, E and F Mode are **CON** and **FAIL**.

The **CON** setting enables normal setpoint operation for Relays. Relays then operates identically to Relay A, B or C, with settings for setpoint, hysteresis, delay and phasing appearing in the CONFIG menu automatically. See Figure 21 for details.

### Temp Units

This function sets the display units for temperature measurement. Press ENTER to initiate user entry mode, and the entire value will flash. Use the UP arrow key to modify the desired display value. The choices are °F and °C. Press ENTER to store the new value.

## 6.25 Control Menu [CONTROL]

The Control Menu contains all of the output control user settings. Note that PID menu items will not appear unless output 1 is configured for PID mode in the CONFIG menu.

**Set PID 0%**  
**Set PID 100%**  
 [lout1=PID]

If the PID is enabled, this function sets the minimum and maximum controller end points. Unlike the standard 4-20 mA output, the controller does not “scale” output values across the endpoints. Rather, the endpoints determine where the controller would normally force minimum or maximum output in an attempt to recover the setpoint (even though the controller can achieve 0% or 100% anywhere within the range.)

If the 0% point is lower than the 100% point, then the controller action will be “reverse” acting. That is, the output of the controller will increase if the measured value is less than the setpoint, and the output will decrease if the measured value is larger than the setpoint. Flipping the stored values in these points will reverse the action of the controller to “direct” mode.

The entry value is limited to a value within the range specified in “Set Range”, and the 0% and the 100% point must be separated by at least 1% of this range. Use the LEFT arrow key to select the first digit to be modified. Then use the UP and LEFT arrow keys to select the desired numerical value. Press ENTER to store the new value.

**PID Setpnt**  
[Iout1=PID]

The measured value which the controller is attempting to maintain by adjusting output value. It is the nature of the PID controller that it never actually gets to the exact value and stops. The controller is continually making smaller and smaller adjustments as the measured value gets near the setpoint.

**PID Prop**  
[Iout1=PID]

Proportional gain factor. The proportional gain value is a multiplier on the controller error (difference between measured value and setpoint value.) Increasing this value will make the controller more responsive.

**PID Int**  
[Iout1=PID]

Integral is the number of “repeats-per-minute” of the action of the controller. It is the number of times per minute that the controller acts on the input error. At a setting of 2.0 rpm, there are two repeats every minute. If the integral is set to zero, a fixed offset value is added to the controller (manual reset.) Increasing this value will make the controller more responsive.

**PID Deriv**  
[Iout1=PID]

Derivative is a second order implementation of Integral, used to suppress “second-order” effects from process variables. These variables may include items like pumps or mixers that may have minor impacts on the measured value. The derivative factor is rarely used in water treatment process, and therefore, it is best in most cases to leave it at the default value. Increasing this value will make the controller more responsive.



**Set 4 mA**  
**Set 20 mA**  
[lout1=D.O.]

These functions set the main 4 and 20 mA current loop output points for the transmitter. The units displayed depend on the selection made in the CONFIG menu for lout #1 Mode. Also, when the Relay Option Board is installed, the units will also display **#1 or #2** – since there are actually two analog outputs present in this version.

The value stored for the 4 mA point may be higher or lower than the value stored for the 20 mA point. The entry values are limited to values within the range specified in “Set Range”, and the 4 mA and the 20 mA point must be separated by at least 1% of this range. Use the LEFT arrow key to select the first digit to be modified. Then use the UP and LEFT arrow keys to select the desired numerical value. Press ENTER to store the new value.

**\*Set 4 mA #2**  
**\*Set 20 mA #2**  
[temp/D.O.]

These functions set the second 4 mA and 20 mA current loop output points for the transmitter. The output may be set to track temperature (default), PPM oxygen, or % Saturation. The values stored for the 4 mA point may be higher or lower than the value stored for the 20 mA point.

The entry value is limited to a value between 0 and 50 °C if it is set for temperature, within the range specified in “Set Range” if the output is set to track oxygen. The 4 mA and the 20 mA point must be at least 20 units away from each other. Press ENTER to initiate user entry mode, and the value will flash. Use arrow keys to modify value. Press ENTER to store the new value.

*NOTE: If the temperature units are changed between °C and °F (see Temp Units in this section), the default settings for this output will be stored (present data is not converted.)*

**\*Set 4 mA #3**  
**\*Set 20 mA #3**  
[temp/D.O.]

**OPTIONAL.** These functions set the optional third 4 mA and 20 mA current loop output points for the analyzer. The output may be set to track temperature (default) or D.O. The values stored for the 4 mA point may be higher or lower than the value stored for the 20 mA point.

The entry value is limited to a value between 0 and 55 °C if it is set for temperature. The 4 mA and the 20 mA point must be at least 20 units away from each other. Press ENTER to initiate user entry mode, and the value will flash. Use arrow keys to modify value. Press ENTER to store the new value.

- \*A Setpoint** This function establishes the oxygen trip point for relay A. The entry value is limited to a value within the range specified in "Set Range". Use the LEFT arrow key to select the first digit to be modified. Then use the UP and LEFT arrow keys to select the desired numerical value. Press ENTER to store the new value.
- \*A Hysteresis** This function establishes the hysteresis, or "deadband", for Relay A. Hysteresis is most often used to control relay chattering; however, it may also be used in control schemes to separate the ON/OFF trip points of the relay. Press ENTER to initiate user entry mode, and the value will flash. Use the arrow keys to modify value. Press ENTER to store the new value.
- \*A Delay** This function places an additional amount of time delay on the trip point for relay A. This delay is in addition to the main delay setting for the controller. The entry value is limited to a value between 0 and 999 seconds. Press ENTER to initiate user entry mode, and the value will flash. Use arrow keys to modify value; range is 0 to 999 seconds. Press ENTER to store the new value.
- \*A Phasing** This function establishes the direction of the relay trip. When phase is HI, the relay operates in a direct mode. Therefore, the relay energizes and the LCD indicator illuminates when the oxygen value **exceeds** the setpoint. When the phase is LO, the relay energizes and the LCD indicator illuminates when the oxygen level drops **below** the setpoint. The failsafe setting does have an impact on this logic. The description here assumes the failsafe setting is OFF. Press ENTER to initiate user entry mode, and the entire value will flash. Use the UP arrow key to modify the desired value; selections include **HI** for direct operation or **LO** for reverse operation. Press ENTER to store the new value.

See Figure 21 - Control Relay Example, Hysteresis & Phase Options below for a visual description of a typical control relay application.

When value rises to  $\geq 1.000$  ppm, relay closes.

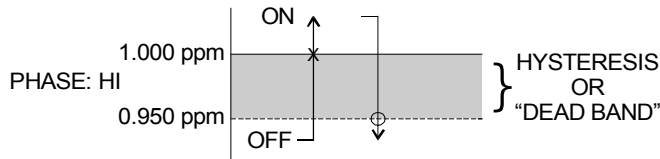

When value rises to  $\geq 1.050$  ppm, relay opens.

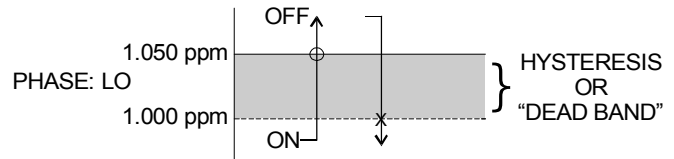

When value falls to  $\leq 0.950$  ppm, relay opens.

When value falls to  $\leq 1.000$  ppm, relay closes.

**Settings:**

- Setpoint: 1.000 ppm
- Hyst: 0.050
- Delay: 000
- Failsafe: OFF

**Figure 21 - Control Relay Example, Hysteresis & Phase Options**

- \*Setpnt A-HI
- \*Hyst A-HI
- \*Delay A-HI
- \*Setpnt A-LO
- \*Hyst A-LO
- \*Delay A-LO

If Relay A Mode is set to Alarm Mode, **AL**, then the following settings will appear in the Config Menu list automatically. In this mode, two setpoints can be selected on the same relay, to create an alarm band. Phase HI selection causes the relay to energize outside of the band, and Phase LO causes the relay to energize inside of the band. This feature enables one relay to be used as a control relay while the other is used as a HI-LO Alarm relay at the same time. Setpoint A-LO must be set lower than Setpoint A-HI. When AL mode is first selected, Setpoint A-LO is defaulted to 0.

Figure 22 - Alarm Relay Example is a visual description of a typical alarm relay application.

When value rises to  $\geq 1.000$  ppm, relay closes, until value falls back to  $\leq 0.950$  ppm.

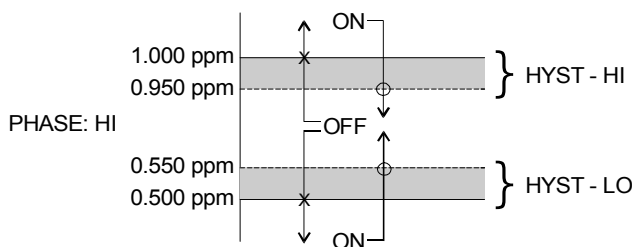

When value falls to  $\leq 1.000$  ppm, relay closes, until rises back to  $\geq 1.050$  ppm.

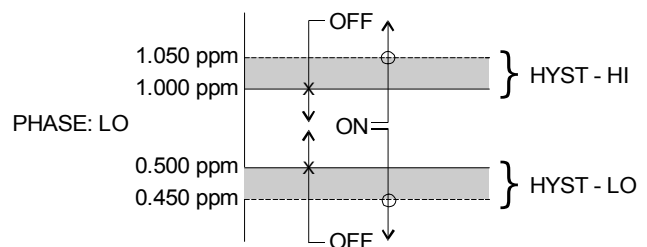

When value falls to  $\leq 0.500$  ppm, relay closes, until rises back to  $\geq 0.550$  ppm.

When value rises to  $\geq 0.500$  ppm, relay closes, until value falls back to  $\leq 0.450$  ppm.

**Settings:**

Setpoint	A-HI: 1.000 ppm	Setpoint	A-LO: .500 ppm
Hyst	A-HI: 0.050	Hyst	A-LO: .0.050
Delay	A-HI: 000	Delay	A-LO: 000

**Figure 22 - Alarm Relay Example**

**\*B Setpoint  
\*B Hysteresis  
\*B Delay  
\*B Phasing**

If Relay B Mode is set to **CON**, then Relay B will function identically to Relay A. Relay B settings appear in the CONFIG menu list automatically.

**C Setpoint  
C Hysteresis  
C Delay  
C Phasing**

If Relay C Mode is set to **CON** (see **Relay C Mode**), then Relay C will function identically to Relay A. Relay C settings appear in the CONFIG menu list automatically.

**D,E,F Setpoint  
D,E,F Hyster  
D,E,F Delay  
D,E,F Phasing**

If Relay D, E, or F Mode is set to **CON** (see **Relay D,E,F Modes**), then the Relay will function identically to Relay A. Relay settings appear in the CONFIG menu list automatically.

**Timer CLEAN  
Timer Cycle  
Timer HOLD**

When Timer Funcs is set to **CLn1** mode, Relays D, E, and F are assigned for automatic cleaning functionality. They can be used with either ATIs (Q-Blast) system, or a customer supplied Air Delivery Source.

Relay E will toggle open/closed based on the time settings entered by the user. The timer **CLEAN** setting controls the amount of time that Relay E is engaged (N.O. contact closed), and the timer **CYCLE** setting controls the amount of time that Relay D is released (N.O. contact open.)

The timer **HOLD** setting allows an output hold time to be entered into the cleaning cycle. This hold time allows the outputs to stabilize back to normal readings before the outputs are released from their "hold" state. Using this feature properly avoids disturbing any instruments

connected to the outputs during the cleaning cycle – where D.O. readings can fluctuate.

To change the values for Timer **CLEAN**, **CYCLE**, and **HOLD**, press ENTER to initiate user entry mode, and entire value will flash. Use the UP arrow key to modify the desired value. Selections for each variable are: CLEAN 1-10 pulses, CYCLE 1-999 hours, HOLD 0-999 minutes. Press ENTER to store the new value.

Example: If the timer-CLEAN setting is 2 pulses, the timer CYCLE setting is 24 hours, and the timer-HOLD setting is 3 minutes, the following sequence will occur: At the instant the timer is enabled (or data for the CLEAN/CYCLE/HOLD is modified) the “CYCLE” time period begins. Once the 24-hour CYCLE period ends, the outputs will be put in hold and relay E will engage for specified amount (Factory Default), (Clean Time) After the CLEAN time has expired, relay E will be released but the hold will stay locked in for an additional 3 minutes (HOLD time), retaining the original output signals. Once the 3 minutes expire, the outputs will be released back to the normal monitoring state. Then, the entire cycle will repeat – approximately once per day.

**Note: The sensor wash timer is not based on a “real-time” clock circuit. Therefore, the time accuracy is only within about 10 minutes per day.**

**Note: A timer wash cycle can be manually started by pressing and holding the ENTER key for a few seconds while viewing the timer status screen in the MEAS menu. The timer must be in the “Tcyc” state to allow a manual start. After this forced cycle, the system will return to normal.**

If the mode selection is changed while the sensor wash timer is in mid-cycle (and the HOLD is enabled), the HOLD must be turned off manually to return all of the outputs to normal operation. A flashing “T” will be seen on the lower line of the display next to temperature while the probe cleaner function is operating.

## 6.26 Diagnostics Menu [DIAG]

The diagnostics menu contains all of the user settings that are specific to the system diagnostic functions, as well as functions that aid in troubleshooting application problems.

### Set Hold

The Set Hold function locks the current loop output values on the present process value and holds relays in current status. This function can be used prior to calibration, or when removing the sensor from the process, to hold the output in a known state. Once HOLD is released, the outputs return to their normal state of following the process input. The transfer out of HOLD is bumpless on the both analog outputs - that is, the transfer occurs in a smooth manner rather than as an abrupt change. An icon on the display indicates the HOLD state, and the HOLD state is retained even if power is cycled. Press ENTER to initiate user entry mode, and entire value will flash. Use the UP arrow key to modify the desired value, selections are **ON** for engaging the HOLD function, and **OFF** to disengage the function. Press ENTER to store the new value.

The Set Hold function can also hold at an output value specified by the user. To customize the hold value, first turn the HOLD function on. Press the ESC key to go to the DIAG Menu and scroll to Sim Output using the UP arrow key. Press ENTER. Follow the instructions under Sim Output (see following page).

### Fault List

The Fault List screen is a read-only screen that allows the user to display the cause of the highest priority failure. The screen indicates the number of faults present in the system and a message detailing the highest priority fault present. Note that some faults can result in multiple displayed failures due to the high number of internal tests occurring. As faults are corrected, they are immediately cleared.

Faults are not stored; therefore, they are immediately removed if power is cycled. If the problem causing the faults still exists, however, faults will be displayed again after power is re-applied and a period of time elapses during which the diagnostic system re-detects them. The exception to this rule is the calibration failure. When a calibration fails, no corrupt data is stored. Therefore, the

system continues to function normally on the data that was present before the calibration was attempted.

After 30 minutes or if power to the transmitter is cycled, the failure for calibration will be cleared until calibration is attempted again. If the problem still exists, the calibration failure will re-occur. Press ENTER to initiate view of the highest priority failure. The display will automatically return to normal after a few seconds.

### **PID Timer**

This function sets a timer to monitor the amount of time the PID controller remains at 0% or 100%. This function only appears if the PID controller is enabled. If the timer is set to 0000, the feature is effectively disabled. If the timer value is set to any number other zero, a FAIL condition will occur if the PID controller remains at 0% or 100% for the timer value. If one of the relays is set to FAIL mode, this failure condition can be signaled by a changing relay contact.

Press ENTER to initiate user entry mode, and the entire value will flash. Use the UP arrow key to modify desired value; range of value is 0-9999 seconds. Press ENTER to store the new value.

### **Sim Out**

The Sim Out function allows the user to simulate the oxygen level of the instrument in the user selected display range. The user enters a ppm value directly onto the screen, and the output responds as if it were actually receiving the signal from the sensor. This allows the user to check the function of attached monitoring equipment during set-up or troubleshooting. Escaping this screen returns the unit to normal operation. Press ENTER to initiate the user entry mode, and the right-most digit of the value will flash. Use arrow keys to modify desired value.

The starting display value will be the last read value of the input. The output will be under control of the SIM screen until the ESC key is pressed.

*Note:* If the HOLD function is engaged before the Sim Output function is engaged, the simulated output will remain the same even when the ESC key is pressed. Disengage the HOLD function to return to normal output.

- Fail Out #1** This function enables the user to define a specified value that the main current output will go to under fault conditions. When the Relay Option Board is installed, the display will read **Fail Out #1**. When enabled to **ON**, the output may be forced to the current value set in **Fail Val** (next item.) With the Fail Out setting of **ON**, and a Fail Val setting of 6.5 mA, any alarm condition will cause the current loop output to drop outside the normal operating range to exactly 6.5 mA, indicating a system failure that requires attention.
- Press ENTER to initiate user entry mode, and the entire value will flash. Use the UP arrow key to modify desired value; selections are **ON**, **OFF**. Press ENTER to store the new value.
- Fail Val #1** Sets the output failure value for lout#1. When **Fail Out** above is set to **ON**, this function sets value of the current loop under a FAIL condition. When the Relay Option Board is installed, the display will read **Fail Out #1**. The output may be forced to any current value between 4-20 mA.
- Press ENTER to initiate user entry mode, and the entire value will flash. Use the UP arrow key to modify desired value; selections are between **4mA**, and **20mA**. Press ENTER to store the new value.
- Fail Out #2** This function sets the fail-mode of current loop output #2 under a FAIL condition. The settings and operation are identical to Fail Out for output #1.
- Fail Val #2** This function sets the value of current loop output #2 under a FAIL condition. The settings and operation are identical to Fail Out for output #1.
- \*Fail Out #3** **OPTIONAL.** This function sets the fail-mode of current loop output #3 under a FAIL condition. The settings and operation are identical to Fail Out for output #1.
- \*Fail Val #3** **OPTIONAL.** This function sets the value of current loop output #3 under a FAIL condition. The settings and operation are identical to Fail Out for output #1.
- Backlight** This function has three options. **ON** – On all the time, **OFF** – Off all the time, **AL** – Alarm (Default). This function flashes the backlight on and off whenever the Fail icon is displayed.



**Start Delay** This function is designed to minimize control or alarm issues arising from temporary power loss. When power goes down, the monitor records the analog output values and the status of relays and PID functions. When power is restored, the analog values and relays will be held at the pre-power loss values for a defined period of time. This “start delay” may be programmed for periods from 0-9.9 minutes. This function is set to 0.0 minutes by default and must be activated by the user if desired by setting a positive time value.

**Cal Check** This feature can be enabled to run at the completion of every autoclean cycle to check sensor operation. When enabled, this feature uses the autocleaner enclosure to blast air past the sensor face, while submerged, for a fixed amount of time. During that time, the sensor saturation reading is checked to see if it is within certain limits (75%-125%). If the reading comes back within range, the autoclean cycle completes as normal. If the reading is out of range, a FAIL diagnostic flag will be tripped and the FAIL relay (if set) can be used to indicate a failure. NOTE – This feature may not work under all circumstances, and must be evaluated for your specific application. Very high flow fluid rates may displace the forced air stream, and a good saturation reading may be difficult to obtain.

**\*Failsafe** This function allows the user to set the optional system relays to a failsafe condition. In a failsafe condition, the relay logic is reversed so that the relay is electrically energized in a normal operating state. By doing this, the relay will not only change state when, for example, an oxygen limit is exceeded, but also when power is lost to the controller.

When failsafe is selected to be ON, the normally-open contacts of the relay will be closed during normal operation. In an attempt to make this configuration less confusing, the LCD icon logic is reversed with this setting, and the icon is OFF under this normal condition. Therefore, when the trip condition occurs, the closed N.O. contacts will be opened (relay de-energized), and the LCD icon will illuminate. In addition, a power fail would also cause the same contacts to open.

**Set Default**

The Set Default function allows the user to return the instrument back to factory default data for all user settings or for just the calibration default. It is intended to be used as a last resort troubleshooting procedure. All user settings or the calibration settings are returned to the original factory values. Hidden factory calibration data remains unchanged. Press ENTER to initiate user entry mode and select either **CAL** or **ALL** with the UP arrow key. The default CAL routine will reset the zero offset to 0.0 nA and reset the slope to 100%. The default ALL routine will reset all program variables to factory default and should be used with care since it will change any user settings that were programmed in the field..

## Part 7 – Calibration

---

### 7.1 Oxygen Calibration

Once power is applied, the sensor must be given time to stabilize. This is best done by following the zeroing procedure below. Establishing a stable zero is critical to the proper operation of the monitor. A complete calibration will include zeroing and spanning the sensor. It is generally unnecessary to set the zero at every calibration, however, it should be done during the initial installation.

#### 7.11 Oxygen Span Cal

The system provides three methods of D.O. calibration: 1-Point (sample), and % Saturation (air cal), and Zero. These three methods are significantly different.

**It is important to note that ONLY the Air Calibration method outlined in section 7.13 may be used to calibrate a D.O. monitor that has been programmed as “Instrument Type 3” in the configuration menu. This type of instrument is designed to measure % Saturation and must be calibrated in air using ambient air as a 100% saturation standard.**

#### 7.12 D.O. Span Cal (1-spl)

The 1-Point (sample or comparison) method is intended to be primarily used as an on-line calibration; however, the sensor can be removed, cleaned and then calibrated in a bucket of clean water if necessary. During calibration, the system will display the current ppm reading and the user can manually enter a reference value from a lab sample or comparative reference instrument. In the Q46D system, the 1-Point calibration adjusts the slope of the sensor output response.

1. Determine whether the calibration will be done on-line or with the sensor removed and placed into a bucket of clean water. If the sensor is removed from the application, rinse and clean if necessary.
2. If the sensor has been removed and placed into a bucket of water, allow sensor to temperature equilibrate with the solution as much as possible. With the sensor coming from an application which differs greatly in temperature, the user may have to wait as much as 20 minutes. If the sensor is on-line, the user may want to set the output HOLD feature prior to calibration to lock out any output fluctuations.
3. Scroll to the CAL menu section using the MENU key and press ENTER or the UP arrow key. **Cal DO** will then be displayed.

4. Press the ENTER key. The screen will display a flashing **1-spl** for 1-point, a **2-%sat** for Saturation calibration, or a **3-zer** for zero calibration. Using the UP arrow key, set for a 1-spl calibration and press ENTER.
5. The system now begins acquiring data for the calibration value. As data is gathered, the units for ppm and temperature may flash. Flashing units indicate that this parameter is unstable. The calibration data point acquisition will stop only when the data remains stable for a pre-determined amount of time. This can be overridden by pressing ENTER.
6. If the data remains unstable for 10 minutes, the calibration will fail and the message **Cal Unstable** will be displayed.
7. The screen will display the last measured ppm value and a message will be displayed prompting the user for the lab value. The user must then modify the screen value with the arrow keys and press ENTER. The system then performs the proper checks.
8. If accepted, the screen will display the message **PASS** with the new slope reading, then it will return to the main measurement display. If the calibration fails, a message indicating the cause of the failure will be displayed and the FAIL icon will be turned on.

### 7.13 D.O. Air Span Cal (% sat)

This is the recommended method for air temperatures greater than about 10C; however, it requires that the sensor be removed from the process and cleaned. Once cleaned, the sensor is held in air and allowed time to adjust to the air temperature. As the sensor temperature equilibrates, the transmitter automatically calculates the new 100% saturation point utilizing the temperature readings and the barometric pressure user data located on page 64. This method therefore requires no user input during calibration. **Note: It is very important to allow enough time for the sensor to completely temperature equilibrate with the surrounding air. This time is at least 10 minutes.**

This method requires that the sensor be removed from the process, cleaned, and Covered, shielding the sensor from direct sunlight. The sensor membrane must be dry for this procedure, and not submerged in liquid. This method requires no user input during calibration; however, if this is the first time the system is being installed and calibrated, make sure to enter the proper atmospheric pressure data and process conductivity data prior to calibration.

1. Remove the sensor from the process. Clean and rinse if necessary with water, paying particular attention to cleaning the membrane.
2. Cover the sensor, if necessary, to shield it from the direct rays of the sun. Remember, the membrane must not be submerged - it must be in the air letting the sensor hang, membrane downward, while powered.
3. Allow the system to operate undisturbed for at least 20 minutes. If the system is stable, the value on the display will increase to some PPM value and remain at that level. At that point, calibration can continue.
4. Scroll to the CAL menu section using the MENU key and press ENTER or the UP arrow key. **Cal D.O.** will then be displayed.
5. Press the ENTER key. The screen will display a flashing **1-spl** for 1-point, a **2-%sat** for Saturation air calibration, or a **3-zer** for zero calibration. Using the UP arrow key, set for a **2-%sat** span calibration and press ENTER.
6. The display will prompt the user to hold the sensor in air and press ENTER. If the sensor has already been removed from the process and reached temperature equilibrium, press the ENTER key.
7. The system now begins acquiring data for the calibration value. As data is gathered, the units for ppm and temperature may flash. Flashing units indicate that this parameter is unstable.
8. The calibration data point acquisition will stop only when the data remains stable for a pre-determined amount of time (approximately 15-20 seconds.) This can be overridden by pressing ENTER. If the data remains unstable for 10 minutes, the calibration will fail and the message **Cal Unstable** will be displayed.
9. If accepted, the screen will display the message **PASS** with the new sensor slope reading, then it will return to the main measurement display. If the calibration fails, a message indicating the cause of the failure will be displayed and the FAIL icon will be turned on.
10. The range of acceptable values for sensor slope is 20% to 250%. It may be necessary to rebuild the sensor as described in section 5, Dissolved Oxygen Sensor Assembly.

Should the slope value remain out of range and result in calibration failures, review the Service Section of this manual, then contact the Service Dept. at ATI for further assistance.

## 7.14 Dissolved Oxygen Zero Cal

Dissolved oxygen sensors have extremely low offset outputs at zero. For this reason, it is normally sufficient to simply leave the zero at the factory default of 0 mV. As an alternative, an electronic zero can be set by disconnecting the sensor from the cable and performing the steps below.

These steps below assume that the sensor has been prepared in accordance with Section 5, Dissolved Oxygen Sensor Assembly, earlier in this manual. Note that the 10 hour waiting time in step 2 below is not required if the monitor has been running for 24 hours prior to zeroing. If the unit has been running with the sensor connected, the sensor will normally return to a stable zero within 15 minutes.

1. Remove the sensor from the application if necessary. Clean and rinse if required.
2. Place about an inch of zero solution in a small beaker or other convenient container and immerse the tip of the sensor. Allow the sensor to sit undisturbed for at least 1 hour. Suspend sensor, DO NOT LET SENSOR SIT ON TIP.
3. Scroll to the CAL menu section using the MENU key and press ENTER or the UP arrow key. **Cal D.O.** will then be displayed.
4. Press the ENTER key. The screen will display a flashing **1-spl** for 1-point, a **2-%sat** for Saturation air calibration, or a **3-zer** for zero calibration. Using the UP arrow key, set for a **3-Zer** zero calibration and press ENTER.
5. The system now begins acquiring data for the sensor zero calibration value. As data is gathered, the units for sensor millivolts (mV) and temperature may flash. Flashing units indicate that this parameter is unstable. The calibration data point acquisition will stop only when the data remains stable for a pre-determined amount of time. This can be overridden by pressing ENTER.
6. If the data remains unstable for 10 minutes, the calibration will fail and the message **Cal Unstable** will be displayed.
7. If accepted, the screen will display the message **PASS** with the new sensor zero reading (offset), then it will return to the main measurement display. If the calibration fails, a message indicating the cause of the failure will be displayed and the FAIL icon will be turned on. The range of acceptable value for sensor offset is -40 mV to +40 mV. Should a FAIL occur, carefully inspect the sensor for a tear in the membrane. It will probably be necessary to rebuild the sensor as described in section 4.4, Dissolved Oxygen Sensor

Assembly. Should the offset value remain high and result in calibration failures, review the Service section of this manual, and then contact the service dept. at ATI for further assistance.

The sensor offset value in mV from the last zero calibration is displayed on the lower line of the Default Menus for information purposes.

## 7.2 Temperature Calibration

The temperature calibration sequence is essentially a 1-point offset calibration that allows adjustments of approximately  $\pm 5^{\circ}\text{C}$ .

The sensor temperature may be calibrated on line, or the sensor can be removed from the process and placed into a known solution temperature reference. In any case, it is critical that the sensor be allowed to reach temperature equilibrium with the solution in order to provide the highest accuracy. When moving the sensor between widely different temperature conditions, it may be necessary to allow the sensor to stabilize as much as one hour before the calibration sequence is initiated. If the sensor is on-line, the user may want to set the output HOLD feature prior to calibration to lock out any output fluctuations.

1. Scroll to the CAL menu section using the MENU key and press ENTER or the UP arrow key.
2. Press the UP arrow key until **Cal Temp** is displayed.
3. Press the ENTER key. The message **Place sensor in solution then press ENTER** will be displayed. Move the sensor into the calibration reference (if it hasn't been moved already) and wait for temperature equilibrium to be achieved. Press ENTER to begin the calibration sequence.
4. The calibration data gathering process will begin. The message **Wait** will flash as data is accumulated and analyzed. The  $^{\circ}\text{C}$  or  $^{\circ}\text{F}$  symbol may flash periodically if the reading is too unstable.
5. The message **Adjust value - press ENTER** will be displayed, and the right-most digit will begin to flash, indicating that the value can be modified. Using the UP and LEFT arrow keys, modify the value to the known ref solution temperature. Adjustments up to  $\pm 5^{\circ}\text{C}$  from the factory calibrated temperature are allowed. Press ENTER.

Once completed, the display will indicate **PASS** or **FAIL**. If the unit fails, the temperature adjustment may be out of range, the sensor may not have achieved complete temperature equilibrium, or there may be a problem with the temperature element. In the event of calibration failure, it is recommended to attempt the calibration again immediately.

## Part 8 – PID Controller Details

---

### 8.1 PID Description

PID control, like many other control schemes, is used in chemical control to improve the efficiency of chemical addition or control. By properly tuning the control loop that controls chemical addition, only the amount of chemical that is truly required is added to the system, saving money. The savings can be substantial when compared to a system which may be simply adding chemical at a constant rate to maintain some minimal addition under even the worst case conditions. The PID output controller is highly advantageous over simple control schemes that just utilize direct (proportional only) 4-20 mA output connections for control, since the PID controller can automatically adjust the “rate” of recovery based on the error between the setpoint and the measured value – which can be a substantial efficiency improvement..

The PID controller is basically designed to provide a “servo”action on the 4-20 mA output to control a process. If the user requires that a measured process stay as close as possible to a specific setpoint value, the controller output will change from 0% to 100% in an effort to keep the process at the setpoint. To affect this control, the controller must be used with properly selected control elements (valves, proper chemicals, etc.) that enable the controller to add or subtract chemical rapidly enough. This is not only specific to pumps and valves, but also to line sizes, delays in the system, etc.

This section is included to give a brief description of tuning details for the PID controller, and is not intended to be an exhaustive analysis of the complexities of PID loop tuning. Numerous sources are available for specialized methods of tuning that are appropriate for a specific application.

### 8.2 PID Algorithm

As most users of PID controllers realize, the terminology for the actual algorithm terms and even the algorithms themselves can vary between different manufacturers. This is important to recognize as early as possible, since just plugging in similar values from one controller into another can result in dramatically different results. There are various basic forms of PID algorithms that are commonly seen, and the implementation here is the most common version; The ISA algorithm (commonly referred to as the “ideal” algorithm.)



$$\text{output} = P \left[ e(t) + \frac{1}{I} \int e(t) dt + D \frac{de(t)}{dt} \right]$$

Where:

output =	controller output
P =	proportional gain
I =	integral gain
D =	derivative gain
t =	time
e(t) =	controller error (e=measured variable – setpoint)

**Figure 23 - ISA PID Equation**

The most notable feature of the algorithm is the fact the proportional gain term affects all components directly (unlike some other algorithms - like the “series” form.) If a pre-existing controller utilizes the same form of the algorithm shown above, it is likely similar settings can for made if the units on the settings are exactly the same. Be careful of this, as many times the units are the reciprocals of each other (i.e. reps-per-min, sec-per-rep.)

PID stands for “proportional, integral, derivative.” These terms describe the three elements of the complete controller action, and each contributes a specific reaction in the control process. The PID controller is designed to be primarily used in a “closed-loop” control scheme, where the output of the controller directly affects the input through some control device, such as a pump, valve, etc.

Although the three components of the PID are described in the setting area (section 6.25), here are more general descriptions of what each of the PID elements contribute to the overall action of the controller.

- P** Proportional gain. With no “I” or “D” contribution, the controller output is simply a factor of the proportional gain multiplied by the input error (difference between the measured input and the controller setpoint.) Because a typical chemical control loop cannot react instantaneously to a correction signal, proportional gain is typically not efficient by itself – it must be combined with some integral action to be useful. Set the P term to a number between 2-4 to start. Higher numbers will cause the controller action to be quicker.
- I** Integral gain. Integral gain is what allows the controller to eventually drive the input error to zero – providing accuracy to the control loop. It must be used to affect the accuracy in the servo action of the controller. Like proportional gain, increasing integral gain results in the control action happening quicker. Set the I term to a number between 3-5 to start (1-2 more than P). Like proportional gain, increasing the integral term will cause the controller action to be quicker.

- D Derivative gain. The addition of derivative control can be problematic in many applications, because it greatly contributes to oscillatory behavior. In inherently slow chemical control processes, differential control is generally added in very small amounts to suppress erratic actions in the process that are non-continuous, such as pumps and valves clicking on and off. However, as a starting point for chemical process control, its best to leave the “D” term set to 0.

Based on these descriptions, the focus on tuning for chemical applications really only involves adjustment of “P” and “I” in most cases. However, increasing both increases the response of the controller. The difference is in the time of recovery. Although combinations of high “P’s” and low “I” will appear to operate the same as combinations of low “P’s” and high “I’s”, there will be a difference in rate of recovery and stability. Because of the way the algorithm is structured, large “P’s” can have a larger impact to instability, because the proportional gain term impacts all the other terms directly. Therefore, keep proportional gain lower to start and increase integral gain to achieve the effect required.

Many of the classical tuning techniques have the user start with all values at 0, and then increase the P term until oscillations occur. The P value is then reduced to ½ of the oscillatory value, and the I term is increased to give the desired response. This can be done with the Q46D controller, with the exception that the I term should start no lower than 1.0.

If it appears that even large amounts of integral gain (>20) don’t appreciably increase the desired response, drop I back to about 1.0, and increase P by 1.00, and start increasing I again. In most chemical control schemes, I will be approximately 3 times the value of P.

### 8.3 Classical PID Tuning

Unlike many high speed position applications where PID loops are commonly used, the chemical feed application employed by this instrument does not require intense mathematical exercise to determine tuning parameters for the PID. In fact, the risk of instability is far greater with overly tuned PID control schemes. In addition, many of the classical mathematical exercises can be damaging or wasteful in the use of chemicals when the process is bumped with large amounts of input error to seek a response curve. Because of this, the general adjustment guidelines described in section 8.2 are sufficient for almost all application tuning for this instrument. Beyond this, many sources are available for classical tuning methods.

#### 8.4 Manual PID Override Control

The Q46 electronics is equipped designed to allow the user to take manual control of the PID output. This is often useful when starting up a control loop, or in the event that you wish to bump the system manually to measure system response time.

To access the manual PID control, you must be in the MEASURE mode of operation and you must have the PID output displayed on the lower line. This line will indicate “XX.X% XX.X mA” with the X values simply indicating the current values. With this display on the screen, press and hold the ENTER key for about 5 seconds. You will see a small “m” show up between the % value and the mA value. This indicates you are now in manual mode.

Once in manual, you may increase the PID output by pressing the UP arrow or you may decrease the output by pressing the LEFT arrow. This will allow you to drive the PID output to any desired setting.

To revert to normal PID control, press and hold the ENTER key again until the “m” indicator disappears.

#### 8.5 Common PID Pitfalls

The most common problem occurring in PID control applications involves the false belief that proper settings on only the PID controller can balance any process to an efficient level.

Close-loop control can only be effective if all elements in the loop are properly selected for the application, and the process behavior is properly understood. Luckily, the nature of simple chemical control process are generally slow in nature. Therefore, even a de-tuned controller (one that responds somewhat slow) can still provide substantial improvements to setpoint control. In fact, damaging oscillatory behavior is far more likely in tightly tuned controllers where the user attempted to increase response too much.

When deciding on a PID control scheme, it is important to initially review all elements of the process. Sticking valves, undersized pumps, or delays in reaction times associated with chemical addition can have a dramatic effect on the stability of the control loop. When controlling a chemical mix or reaction, the sensor should be placed in a location that ensures proper mixing or reaction time has occurred.

The easiest process' to control with closed-loop schemes are generally linear, and symmetrical, in nature. For example, controlling level in tank where the opening of valve for a fixed period of time corresponds linearly to the amount that flows into a tank. Chemical control process' can be more problematic when the nature of the setpoint value is non-linear relative to the input of chemical added. For example, D.O. control of a process may appear linear only in a certain range of operation, and become highly exponential at the extreme ranges of the measuring scale. In addition, if a chemical process is not symmetrical, that means it responds differentially to the addition and subtraction of chemical. It is important in these applications to study steady-state impact as well as step-change impact to process changes. In other words, once the process has apparently been tuned under normal operating conditions, the user should attempt to force a dramatic change to the input to study how the output reacts. If this is difficult to do with the actual process input (the recommended method), the user can place the control in manual at an extreme control point such as 5% or 95%, and release it in manual. The recovery should not be overly oscillatory. If so, the loop needs to be de-tuned to deal with that condition (reduce P and/or I.)

# Part 9 – System Maintenance

---

## 9.1 General

The Q46D/60 Dissolved Oxygen System will generally provide unattended operation over long periods of time. With proper care, the system should continue to provide measurements indefinitely. For reliable operation, maintenance on the system must be done on a regular schedule. Keep in mind that preventive maintenance on a regular schedule is much less troublesome than emergency maintenance that always seems to come at the wrong time.

## 9.2 Analyzer Maintenance

No unusual maintenance of the analyzer is required if installed according to the guidelines of this operating manual. If the enclosure door is frequently opened and closed, it would be wise to periodically inspect the enclosure sealing gasket for breaks or tears.

## 9.3 Sensor Maintenance

Sensor maintenance is required for accurate measurements. The primary requirement is simply to keep the sensor membrane clean. The membrane is a polymer material that is resistant to anything that will be encountered in water streams. However, deposits or biological growth can form on the surface of the membrane, and these deposits will reduce the sensitivity to oxygen. Normally, these coatings can be removed by simply wiping the membrane with a soft cloth or paper towel.

Should a coating form on the membrane that does not wipe off, it is best to change the membrane. Chemical cleaning may work as well, but a new membrane is a more reliable solution. To change a membrane, follow the Sensor Assembly procedure in this manual. Do not reuse the electrolyte from the sensor when changing a membrane. Always refill with fresh electrolyte. The electrolyte is stable and does not have a limited shelf life.

Even if no buildup is apparent on the membrane, it should be changed on a regular schedule. The recommended membrane change interval is every 6-12 months depending on application. The actual membrane life is often in excess of one year, but periodic preventive maintenance will simply avoid having to do service on an emergency basis.

While the sensor is disassembled for membrane changing, examine the condition of the o-rings on both ends of the electrolyte canister. If the o-rings show any signs of damage, replace them with new ones from the spare parts kit. It is good practice to change these o-rings once a year, regardless of their condition.

### **9.31 Lead Anode Replacement**

Galvanic D.O. sensors consume the lead electrode during normal operation. As oxygen is measured, lead is converted to lead oxide, and after a period of time, the lead is expended. The lead electrode in ATI's D.O. sensor cartridge can be easily replaced (part # 04-0003), and replacement should be done automatically every 12 months.

The lead electrode is the thick lead wire wrapped around the sensor body. It is connected through a stainless steel post with a nut and star washer. To change the lead electrode, remove the nut and washer and unwrap the old lead. Loop the end of a new lead electrode around the post and replace the nut and washer. Tighten the nut firmly but do not over tighten as damage to the sensing module can result. Wrap the remainder of the lead around the sensor body. There is no need to secure the other end of the lead.

### **9.32 Pressure Compensator Rebuild**

On the side of the electrolyte chamber is a pressure compensator gland assembly. Refer to Figure 18 - Flow Type D.O. Sensor Assembly for an exploded view of this assembly. Normally, this assembly does not require service, but it is possible that the pressure gland inside this assembly might be punctured if excessive pressure is applied. Rebuilding the gland is relatively easy using the parts supplied with the sensor.

You will need either a torque wrench (preferred) or a wide bladed screwdriver to remove the retaining nut. Unscrew the nut and set it aside. Then carefully remove the old gasket and membrane. A small tweezers is useful in handling the replacement parts.

Carefully place a new membrane (clear material) into the gland recess. Place a white gasket on top of the clear membrane. Replace the retaining nut, tightening it just enough to insure that the white gasket material compresses for a good seal. To test the integrity, put a new membrane on the bottom of the chamber and fill the chamber with water. Look for any liquid leaks coming from the gland area. If you note leakage, tighten the nut a bit more.

# Part 10 – Troubleshooting

---

## 10.1 General

The information included in this section is intended to be used in an attempt to quickly resolve an operational problem with the system. During any troubleshooting process, it will save the most time if the operator can first determine if the problem is related to the analyzer, sensor, or some external source. Therefore, this section is organized from the approach of excluding any likely external sources, isolating the analyzer, and finally isolating the sensor. If these procedures still do not resolve the operational problems, any results the operator may have noted here will be very helpful when discussing the problem with the factory technical support group.

## 10.2 External Sources of Problems

To begin this process, review the connections of the system to all external connections.

1. Verify the analyzer is earth grounded. For all configurations of the analyzer, an earth ground connection **MUST** be present for the shielding systems in the electronics to be active. Grounded conduit provides no earth connection to the plastic enclosure, so an earth ground wiring connection must be made at the power input terminal strip. Use the special “shield terminal” stub on the power supply board for optimum sensor cable shield grounding.
2. Verify the proper power input is present (115/230 VAC.)
3. Verify the loads on any 4-20 mA outputs do not exceed the limits in the Instrument Specifications (500 Ohms each for analyzer.) During troubleshooting, it is many times helpful to disconnect all these outputs and place wire-shorts across the terminals in the instrument to isolate the system and evaluate any problems which may be coming down the analog output connections.
4. Do not run sensor cables or analog output wiring in the same conduits as power wiring. If low voltage signal cables must come near power wiring, cross them at 90° to minimize coupling.

5. If rigid conduit has been run directly to the Q46 enclosure, check for signs that moisture has followed conduit into the enclosure.
6. Check for ground loops. Although the membrane sensor is electrically isolated from the process water, high frequency sources of electrical noise may still cause erratic behavior in extreme conditions. If readings are very erratic after wiring has been checked, check for a possible AC ground loop by temporarily placing the sensor into a bucket of water. The reading should be initially stable and then fall very slowly in a smooth fashion as the powered sensor depletes oxygen in the static sample directly at the sensor face.
7. On relay based systems, check the load that is connected to the relay contacts. Verify the load is within the contact rating of the relays. Relay contacts which have been used for higher power AC current loads may become unsuitable for very low signal DC loads later on because a small amount of pitting can form on the contacts. If the load is highly inductive (solenoids, motor starters, large aux relays), note that the contact rating will be de-rated to a lower level. Also, due to the large amount of energy present in circuits driving these types of loads when they are switched on an off, the relay wiring placement can result in electrical interference for other devices. This can be quickly resolved by moving wiring, or by adding very inexpensive snubbers (such As Quencharcs) to the load.
8. Carefully examine any junction box connections for loose wiring or bad wire stripping. If possible, connect the sensor directly to the analyzer for testing.
9. Check sensor membrane for fouling. Look closely for signs of grease or oil which may be present. Replace membrane and electrolyte, allow to stabilize, and re-check. The procedure in Oxygen Sensor Assembly, on page 26, must be followed when replacing the membrane.



### 10.3 Analyzer Tests

1. Disconnect power and completely disconnect all output wiring coming from the analyzer. Remove sensor wiring, relay wiring, and analog output wiring. Re-apply power to the analyzer. Verify proper voltage (115 or 230 VAC) is present on the incoming power strip of the analyzer, and that the analyzer power label matches the proper voltage value.
2. If analyzer does not appear to power up (no display), remove power and check removable fuse for continuity with a DVM.
3. Using a DVM, check the voltage across the BLUE and WHITE wires coming from the power supply board in the base of the enclosure. FIRST, disconnect any wiring going to lout#1. Then, verify voltage across these wires is about 16-18 VDC when still connected to the terminal strip on the front half of the enclosure. If the BLUE and WHITE wires are not connected to the terminal strip on the front half of the enclosure, the voltage across them should measure about 29 VDC.
4. If analyzer does power up with a display, use the "Simulate" feature to check operation of the analog outputs (and relays contacts with a DVM.)
5. Check sensor power circuits. With a DVM, verify between -4.5 and -5.5 VDC from sensor connection terminals WHITE (+) to BLACK (-). Then verify between +4.5 and +5.5VDC from GREEN (+) to BLACK (-).
6. Check TC drive circuit. Place a wire-short between the RED and BLACK sensor terminals. With a DVM, measure the voltage between the BLACK (-) and BROWN (+) sensor terminals to verify that the TC drive circuit is producing about -4.6 to -5.5 VDC open-circuit. Remove DVM completely and connect a 1000 Ohm resistor across the BLACK to BROWN terminals. The temperature reading on the front LCD should display approximately 0°C and the dissolved oxygen reading should display approximately 0 ppm.

#### 10.31 Display Messages

The Q46 Series instruments provide a number of diagnostic messages which indicate problems during normal operation and calibration. These messages appear as prompts on the secondary line of the display or as items on the Fault List.

MESSAGE	DESCRIPTION	POSSIBLE CORRECTION
<b>Max is 200</b>	Entry failed, maximum user value allowed is 200.	Reduce value to $\leq 200$
<b>Min is 200</b>	Entry failed, minimum value allowed is 200.	Increase value to $\geq 200$
<b>Cal Unstable</b>	Calibration problem, data too unstable to calibrate. Icons will not stop flashing if data is too unstable. User can bypass by pressing ENTER.	Clean sensor, get fresh cal solutions, allow temperature and conductivity readings to fully stabilize, do not handle sensor or cable during calibration.
<b>Out of Range</b>	Input value is outside selected range of the specific list item being configured.	Check manual for limits of the function to be configured.
<b>Locked!</b>	Transmitter security setting is locked.	Enter security code to allow modifications to settings.
<b>Unlocked!</b>	Transmitter security has just been unlocked.	Displayed just after security code has been entered.
<b>Offset High</b>	The sensor zero offset point is out of the acceptable range of -40 to +40 mV.	Check wiring connections to sensor. Allow sensor to operate powered a minimum of 12 hours prior to first zero cal.
<b>Sensor High</b>	The raw signal from the sensor is too high and out of instrument range.	Check wiring connections to sensor.
<b>Sensor Low</b>	The raw signal from the sensor is too low.	Check wiring connections to sensor.
<b>D.O. High</b>	The oxygen reading is greater than the maximum of the User-selected range.	The oxygen reading is over operating limits. Set measuring range to the next highest level.
<b>Temp High</b>	The temperature reading is $> 55^{\circ}\text{C}$ .	The temperature reading is over operating limits. Check wiring and expected temp level. Perform RTD test as described in sensor manual. Recalibrate sensor temperature element if necessary.
<b>Temp Low</b>	The temperature reading is $< -10^{\circ}\text{C}$	Same as "Temp High" above.
<b>TC Error</b>	TC may be open or shorted.	Check sensor wiring and perform RTD test as described in sensor manual. Check j-box connections.

**Figure 24 - Display Messages**

MESSAGE	DESCRIPTION	POSSIBLE CORRECTION
<b>D.O. Cal Fail</b>	Failure of oxygen calibration. FAIL icon will not extinguish until successful calibration has been performed, or 30 minutes passes with no keys being pressed.	Clean sensor redo zero and span calibration. If still failure, sensor slope may be less than 20% or greater than 500%. Perform sensor tests as described in section 10.4. Replace sensor if still failure.
<b>TC Cal Fail</b>	Failure of temperature calibration. FAIL icon will not extinguish until successful calibration has been performed, or 30 minutes passes with no keys being pressed.	Clean sensor, check cal solution temperature and repeat sensor temp calibration. TC calibration function only allows adjustments of +/- 6 °C. If still failure, perform sensor tests as described in section 10.4. Replace sensor if still failure. .
<b>EPROM Fail</b>	Internal nonvolatile memory failure	System failure, consult factory.
<b>Chcksum Fail</b>	Internal software storage error.	System failure, consult factory.
<b>Display Fail</b>	Internal display driver fail.	System failure, consult factory.
<b>Range Cal Fail</b>	Failure of factory temperature calibration.	Consult factory.

#### 10.4 Sensor Tests

1. Check the membrane condition. A membrane that is not stretched smoothly across the tip of the sensor will cause unstable measurements. If necessary, change membrane and electrolyte.
2. Dissolved oxygen sensors can be tested with a digital voltmeter (DVM) to determine if a major sensor problem exists. Follow the steps below to verify sensor integrity:
  - A. Prior to disconnecting the sensor, measure the sensor output voltage at the analyzer terminal strip with a DVM while the sensor is hanging in air. If the sensor has been connected to a powered analyzer for at least 12 hours, the nominal output of the sensor will be about +400mVDC when measured in air at 25C (100% saturation) from BLACK (-) to RED (+) on the analyzer terminal strips. This value is affected by temperature, pressure, and age of the sensor so it's possible to see a typical value that ranges from perhaps +200mVDC to about +800 mVDC under a wide range of conditions in air.
  - A. Disconnect the five sensor wires from the oxygen monitor. Those wires are color coded red, white, blue, green, brown, and black. Note that the brown wire may be replaced with a orange wire in some cables.
  - B. Remove the front sensor "cartridge" for the sensor body by unscrewing the cartridge at the large "knurl" in a counter clockwise manner. Inspect the gold RCA jack for signs of moisture or other foulants. Clean and thoroughly dry both connectors if necessary. Re-assemble when complete.
  - E. Connect the DVM between the brown and black wires. These are the RTD leads, and you should find a resistance value that depends on the temperature. The table below lists the resistance values for various temperatures.

Temperature °C	Resistance Ω
0	1000
5	1019
10	1039
15	1058
20	1078
25	1097
30	1117
35	1136
40	1155
45	1175
50	1194

**Figure 25 - Pt100 RTD Resistance Table**

If you suspect that water has gotten into a cable connection or into the plug connection of a submersible sensor, disconnect the cable and allow the parts of the sensor to sit in a warm place for 24 hours. If water in the connector is the problem, it should dry out sufficiently to allow normal sensor operation.

<b>Barometric Pressure Conversion</b>		
<b>Inches of Mercury(inHg)</b>	<b>Millimeters of Mercury (mmHg)</b>	<b>Feet Above Sea Level</b>
22.00	558.8	+8790
22.50	571.5	+8053
23.00	584.2	+7347
23.50	596.9	+6671
24.00	609.6	+6023
24.50	622.3	+5402
25.00	635.0	+4806
25.50	647.7	+4233
26.00	660.4	+3682
26.50	673.1	+3156
27.00	685.5	+2653
27.50	698.5	+2150
28.00	711.2	+1675
28.50	723.9	+1217
29.00	736.6	+776
29.50	749.3	+349
30.00	762.0	-64
30.50	774.7	-463
31.00	784.4	-759

**Figure 26 - Reference, Barometric Conversion Table**

Water Saturated Concentration of O <sub>2</sub>					
Temperature		PPM	Temperature		PPM
°F	°C		°F	°C	
32	0.0	14.6	74	23.3	8.5
34	1.1	14.1	76	24.4	8.3
36	2.2	13.7	78	25.6	8.2
38	3.3	13.3	80	26.7	8.0
40	4.4	12.9	82	27.8	7.8
42	5.6	12.6	84	28.9	7.7
44	6.7	12.2	86	30.0	7.5
46	7.8	11.9	88	31.1	7.4
48	8.9	11.6	90	32.2	7.3
50	10.0	11.3	92	33.3	7.1
52	11.1	11.0	94	34.4	7.0
54	12.2	10.7	96	35.6	6.9
56	13.3	10.4	98	36.7	6.8
58	14.2	10.2	100	37.8	6.6
60	15.6	9.9	102	38.9	6.5
62	16.7	9.7	104	40.0	6.4
64	17.8	9.5	106	41.1	6.3
66	18.9	9.3	108	42.2	6.2
68	20.0	9.1	110	43.3	6.1
70	21.1	8.9	112	44.4	6.0
72	22.2	8.7	114	45.6	5.9

**Figure 27 - Reference, D.O. Saturation vs. Temperature**

# Spare Parts

---

<u>Part No.</u>	<u>Description</u>
03-0393	Q46D Front Lid electronics assembly
07-0320	AC Powered monitor electronics assembly, 100-240 VAC
07-0321	DC Powered monitor electronics assembly 12-24 VDC
07-0322	AC Powered monitor electronics assembly w/Profibus, 100-240 VAC
07-0323	DC Powered monitor electronics assembly w/Profibus, 12-24 VDC
23-0022	Fuse, 250mA, 250V, TR-5 (for AC and DC Analyzers)
07-0078	Flow Type D.O. sensor
07-0095	Oxygen sensor, submersion type with 30' cable
02-0007	Submersion sensing module, (for #07-0095)
02-0014	Submersion element body, (for #02-0007)
02-0113	Submersion holder, 30' cable (for #07-0095)
02-0224	Flow Type Sensor Element (for 07-0078)
03-0358	Electrolyte Chamber with pressure gland
48-0001	Membrane holder, type 316 stainless steel
45-0010	Membrane holder, noryl
04-0003*	Lead Electrode
05-0001*	5-mil Membranes, pkg. of 10
05-0011*	2-mil Membranes, pkg. of 10
05-0014	Spare Parts Kit, screw & o-ring (Submersible Sensor)
05-0015	Spare Parts Kit, screw & o-ring (Flow Sensor)
05-0088	Pressure gland rebuild kit
42-0014	Flowcell O-ring
09-0007*	Dissolved oxygen electrolyte, 4 oz (120 cc)
07-0100	Junction box
31-0001	Interconnect cable for junction box to monitor wiring
38-0072	Terminal block plug, 3 position (Relays)
38-0073	Terminal block plug, 4 position (Outputs)
38-0074	Terminal block plug, 3 position (Cable Shields)
38-0075	Terminal block plug, 3 position (Power)
31-0173	20 Pos. Ribbon cable assembly
00-1522	Sealed Flowcell Assembly
05-0110	Sealed Flowcell Vacuum Breaker

**Note:** Instrument is supplied with sufficient spare parts for 12 months of operation. For 2 year spare parts inventory, 1 each of the items marked with an asterisk are required.

**Lock/Unlock Code: 1463**