

GasSens

Alcohol Gas Monitor

Home Office

Analytical Technology, Inc.
6 Iron Bridge Drive
Collegeville, PA 19426

Ph: (800) 959-0299
(610) 917-0991

Fax: (610) 917-0992

Email: sales@analyticaltechnology.com

European Office

ATI (UK) Limited
Unit 1 & 2 Gatehead Business Park
Delph New Road, Delph
Saddleworth OL3 5DE

Ph: 0800-018-4020

+ 44 (0) 1457-873-318

Fax: + 44 (0)1457-874-468

Email: sales@atiuk.com

PRODUCT WARRANTY

Analytical Technology, Inc. (Manufacturer) warrants to the Customer that if any part(s) of the Manufacturer's products proves to be defective in materials or workmanship within the earlier of 18 months of the date of shipment or 12 months of the date of start-up, such defective parts will be repaired or replaced free of charge. Inspection and repairs to products thought to be defective within the warranty period will be completed at the Manufacturer's facilities in Collegeville, PA. Products on which warranty repairs are required shall be shipped freight prepaid to the Manufacturer. The product(s) will be returned freight prepaid and allowed if it is determined by the manufacturer that the part(s) failed due to defective materials or workmanship.

This warranty does not cover consumable items, batteries, or wear items subject to periodic replacement including lamps and fuses.

Gas sensors, except oxygen sensors, are covered by this warranty, but are subject to inspection for evidence of extended exposure to excessive gas concentrations. Should inspection indicate that sensors have been expended rather than failed prematurely, the warranty shall not apply.

The Manufacturer assumes no liability for consequential damages of any kind, and the buyer by acceptance of this equipment will assume all liability for the consequences of its use or misuse by the Customer, his employees, or others. A defect within the meaning of this warranty is any part of any piece of a Manufacturer's product which shall, when such part is capable of being renewed, repaired, or replaced, operate to condemn such piece of equipment.

This warranty is in lieu of all other warranties (including without limiting the generality of the foregoing warranties of merchantability and fitness for a particular purpose), guarantees, obligations or liabilities expressed or implied by the Manufacturer or its representatives and by statute or rule of law.

This warranty is void if the Manufacturer's product(s) has been subject to misuse or abuse, or has not been operated or stored in accordance with instructions or if the serial number has been removed.

Analytical Technology, Inc. makes no other warranty expressed or implied except as stated above.

TABLE OF CONTENTS

TABLE OF CONTENTS..... 1

INTRODUCTION..... 1-3

A11 SENSOR/TRANSMITTER 1-4

A14 RECEIVER MODULE..... 1-4

A17 POWER SUPPLY MODULE..... 1-4

NEMA 4X ENCLOSURES 1-4

EXPLOSION-PROOF ENCLOSURES..... 1-4

AUDIBLE HORN..... 1-5

STROBE LAMP..... 1-5

A19 BATTERY BACK-UP 1-5

MECHANICAL INSTALLATION 1-6

ELECTRICAL INSTALLATION..... 1-11

RECEIVER MODULE..... 2-1

INTRODUCTION 2-1

ELECTRICAL CONNECTION..... 2-1

FACTORY CONFIGURATION..... 2-3

CONFIGURATION SWITCHES..... 2-3

SETPOINT SELECTION 2-5

RANGE SELECTION 2-6

RELAY CONFIGURATION..... 2-6

EXTERNAL HORN RELAY 2-7

DISPLAY INTENSITY 2-7

OPERATION 2-8

STARTUP..... 2-8

ALARM ACKNOWLEDGE AND RESET 2-8

TROUBLE ALARM AND RELAY 2-9

AUTO-TEST FUNCTION (OPTIONAL) 2-9

LAMP AND HORN TEST 2-10

RELAY INHIBIT..... 2-10

MANUAL AUTO-TEST 2-11

REMOTE RESET 2-11

ANALOG OUTPUT 2-11

AUTO-TEST REMOTE VERIFICATION..... 2-12

DEACTIVATING THE AUTO-TEST FUNCTION..... 2-12

TROUBLESHOOTING..... 2-13

RECEIVER MODULE PARTS LIST..... 2-14

A17 UNIVERSAL POWER SUPPLY 3-1

POWER SUPPLY PARTS LIST..... 3-3

OPTIONAL EQUIPMENT 4-1

INSTALLATION 4-1

OPERATION..... 4-2

REMOVAL FROM SERVICE 4-2

BATTERY BACKUP PARTS LIST 4-3

STROBE PARTS LIST..... 4-3

STROBE LIGHT 4-3

INTRODUCTION

GasSens is an on-line monitoring system for the detection of hazardous gases in ambient air. It is designed to detect and alarm gas leaks from storage cylinders, process piping, or gas feed equipment in virtually any type of industrial plant environment. Systems are available for monitoring a variety of gases as shown in Table 1-1.

TABLE 1-1

GAS	CODE NO.	STD. RANGE	MIN. RANGE	MAX. RANGE
GENERAL GASES				
Ammonia	15*	0-100 PPM	0-50 PPM	0-500 PPM
Carbon Monoxide	16*	0-100 PPM	0-50 PPM	0-500 PPM
Hydrogen	18	0-4%	0-2000 PPM	0-10%
Nitric Oxide	25	0-100 PPM	0-25 PPM	0-500 PPM
Oxygen	19	0-25%	0-10%	0-100%
Phosgene	20	0-2 PPM	0-1 PPM	0-100 PPM
OXIDANT GASES				
Bromine	10*	0-2 PPM	0-1 PPM	0-100 PPM
Chlorine	11*	0-10 PPM	0-1 PPM	0-100 PPM
Chlorine Dioxide	12*	0-2 PPM	0-1 PPM	0-100 PPM
Fluorine	13*	0-2 PPM	0-1 PPM	0-100 PPM
Hydrogen Peroxide	34	0-10 PPM	0-10 PPM	0-100 PPM
Ozone	14*	0-2 PPM	0-1 PPM	0-100 PPM
Iodine	35*	0-2 PPM	0-1 PPM	0-100 PPM
ACID GASES				
Hydrogen Chloride	21*	0-20 PPM	0-10 PPM	0-200 PPM
Hydrogen Cyanide	22*	0-20 PPM	0-10 PPM	0-200 PPM
Hydrogen Fluoride	23*	0-20 PPM	0-10 PPM	0-200 PPM
Hydrogen Sulfide	24*	0-50 PPM	0-10 PPM	0-500 PPM
Nitrogen Dioxide	26*	0-20 PPM	0-5 PPM	0-200 PPM
Sulfur Dioxide	27*	0-20 PPM	0-10 PPM	0-200 PPM
HYDRIDE GASES				
Arsine	28	0-1000 PPB	0-1000 PPB	0-100 PPM
Diborane	29	0-1000 PPB	0-1000 PPB	0-100 PPM
Germane	30	0-1000 PPB	0-1000 PPB	0-100 PPM
Hydrogen Selenide	31	0-1000 PPB	0-1000 PPB	0-100 PPM
Phosphine	32	0-1000 PPB	0-1000 PPB	0-100 PPM
Silane	33	0-10 PPM	0-1000 PPB	0-100 PPM

* Auto-Test is available in these gases.

The **GasSens** system consists of modular components that can be used in a variety of configurations to fit specific application requirements. A description of the major system components follows:

A11 Sensor/Transmitter

Consists of an electrochemical gas sensor closely coupled to a NEMA 4X transmitter. This component measures gas concentration and converts the measurement to a digital signal for transmission to a receiver module. It must be mounted in the area where gas leakage or buildup is expected, and can either be wall mounted or supported by electrical conduit carrying interconnecting wiring. Sensor/transmitters are available with optional **Auto-Test**, an electrochemical gas generator which automatically tests sensor response daily and alarms any sensor problems. For hazardous areas, explosion-proof sensor/transmitters are available.

A14 Receiver Module

Receives digital data from the sensor/transmitter and provides an LED display of gas concentration, two gas alarm setpoints, three gas alarm relays, an isolated 4-20 mA output, and a trouble alarm and relay. The receiver is packaged in a compact DIN rail mount housing, and fits easily into NEMA 4X enclosures suitable for one, two, three, or six modules. Each module is switch programmable for full scale range, alarm setpoints, relay latch/non-latch operation, and relay normal/fail-safe operation. A single switch (marked A/R) on the front panel provides alarm acknowledge and reset functions, and can also be used to test front panel LED indicators and to inhibit alarm relays. LED bars on the front panel provide visual indication of alarm status.

A17 Power Supply Module

Provides 12 VDC power to one or two receiver modules plus power for an audible horn and for charging an external battery. Packaged in the same compact DIN rail mount module used for the receiver, the power supply is designed for use throughout the world. Input to this module may be any AC (50 or 60 Hz.) or DC voltage between 85 and 270 volts. The supply is self-regulating, meaning no jumper changes, no changes in switch settings, and no variation in wiring pattern. A power failure alarm relay is included in the module to signal the loss of input power.

NEMA 4X Enclosures

Four standard enclosures are available for housing receiver and power supply modules. Polystyrene enclosures are suitable for outdoor environments, and digital displays and alarm indicators are clearly visible through a clear polycarbonate window on the front. The window hinges open to gain access to the receiver A/R control switch, and the entire front section of the enclosure can be removed for ease of mounting and wiring. Enclosures are provided with knockouts on all four sides to facilitate wiring, and 1/2" FNPT conduit hubs are provided with each enclosure.

Explosion-proof Enclosures

Two versions are available to allow use of the receiver and power supply modules in hazardous areas. One version is suitable for a single receiver module, while the second is large enough to contain both a power supply and a receiver. Enclosures are rated for Class 1, Division 1, Groups C & D. Group B enclosures are also available if required. All explosion-proof enclosures can be supplied with an external acknowledge and reset switch.

Audible Horn

A 12 VDC piezoelectric alarm horn is available for mounting into any of the NEMA 4X enclosures. The horn is wired to the receiver module and will sound intermittently when the warning setpoint is reached, and continuously when the alarm setpoint is reached. The horn can be silenced by pushing the A/R switch on the receiver front panel. A single horn can be wired through multiple receivers and will sound if any receiver goes into alarm.

Strobe Lamp

Provides a bright visual indication of an alarm condition. The strobe uses a xenon flash lamp to give a high intensity flash approximately 70 times a minute. The strobe is wired to one of the alarm relays, with power for the strobe supplied from the power supply module. Mounting is by 1/2" MNPT nipple, making it convenient to mount directly to a NEMA enclosure.

A19 Battery Back-up

Provides a 12 VDC, 4 AH battery and charging control circuitry in a separate NEMA 4X enclosure. The battery backup connects directly to the A17 power supply module to provide standby power to the detection system. If AC power is lost, the battery insures that detection continues uninterrupted.

GasSens components allow simple assembly of either single or multipoint detection systems. Each point of detection requires one sensor/transmitter and one receiver. The sensor/transmitter is mounted in the hazard area, and the receiver is located anywhere within 1000 feet. If the user has a regulated 12 VDC power supply and an enclosure to house the receiver, nothing else is required. If not, one power supply for every two receivers is needed for power, and an enclosure of a size to contain the modules is needed for environmental protection. An optional horn and strobe may be added if desired.

MECHANICAL INSTALLATION

System enclosures, battery back-up units, and sensor transmitters are all designed for surface mounting using screws or bolts inserted through the recessed mounting holes at each corner of the enclosures. Included with each system enclosure is a template with mounting hole dimensions for two and three module system enclosures, battery back-up enclosure, and sensor/transmitter enclosure. The template can be used to mark hole centers on walls or mounting panels.

Mounting recesses are suitable for #6 or #8 machine screws or wood screws. Screw length will vary with specific site conditions.

Two and three module system enclosures provide knockouts on all four sides to allow wiring conduit to be connected in the most convenient way. Enclosures are shipped with all knockouts in place except for the larger knockout on the bottom, where the audible horn is installed if ordered. See pages 1-6 through 1-9 for dimensional drawings of the one, two, three and six module enclosures.

Each enclosure is supplied with conduit hubs for connection of 1/2" NPT threaded conduit. Also included is a seal ring for each hub. **Seal rings are required to provide a water tight conduit hub connection to the enclosure.** The following lists the number of hubs that should be included with each enclosure type.

- Two module Enclosure - 4 hubs
- Three module Enclosure - 6 hubs
- Six Module Enclosures - 6 hubs
- Battery back-up Enclosure - 2 hubs
- Sensor/Transmitter Enclosure - 1 hub

Conduit hubs are installed in any enclosure knockout labeled PG16. Note that some knockouts have more than one designation, such as PG11/16. Those with two designations will have concentric circles for knockouts. The inner circle marks the lower PG number while the outer circle marks the higher number. Place a thin bladed screwdriver into the circular slot or the desired knockout size and tap firmly with a hammer. To install the hub, place the seal ring over the threaded part of the hub. Locate the hub nut on the inside of the enclosure and screw the hub into the hub nut from the outside. Tighten firmly to insure that the seal ring provides a good seal between the hub and the outside of the enclosure.



For installations where conduit will not be used, cable gland seal fittings must be installed in the conduit hubs. Plastic cable glands are available from most electrical supply stores. Gland seals with 1/2" NPT threads will screw directly into the conduit hub. Gland seals are also available from ATI for installation directly into the enclosures in place of the conduit hubs. Refer to the parts list for the correct part number of the cable gland seals.

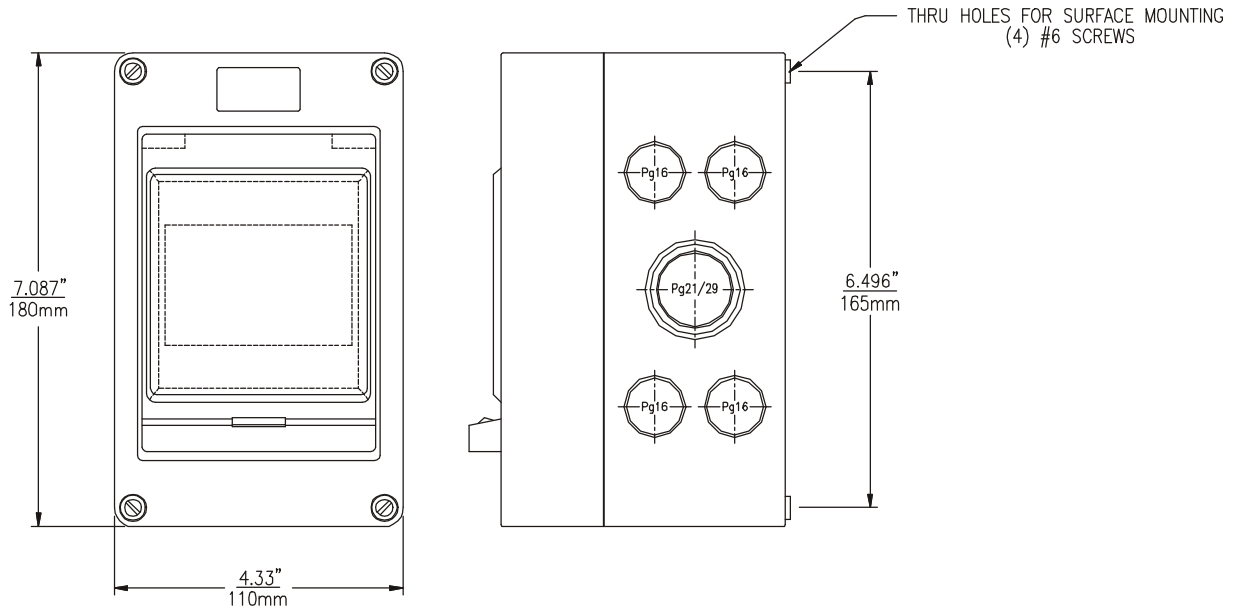

Figure 1-1: Single Module System Enclosure Dimensions (80-0005R)

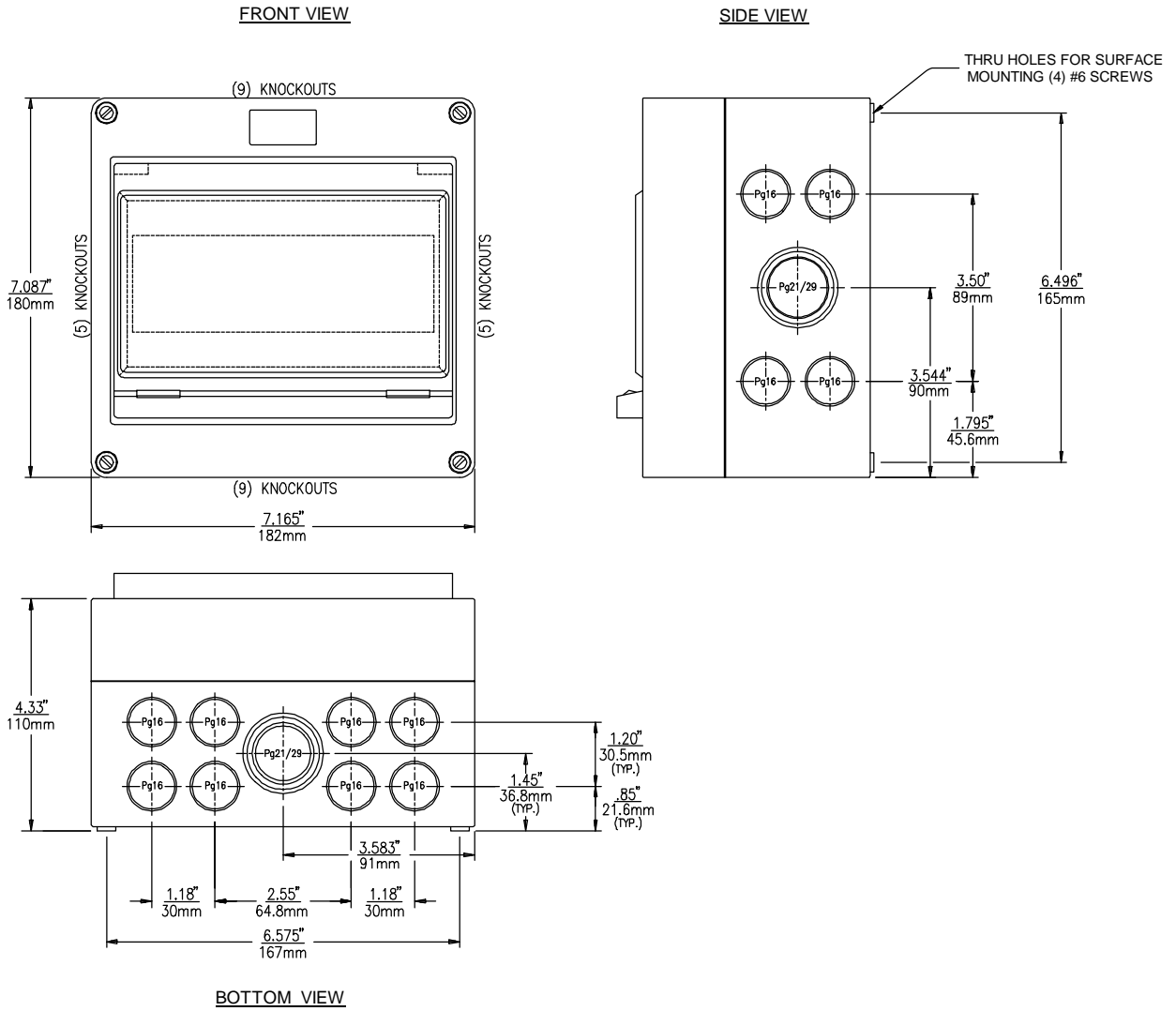

Figure 1-2: Two Module System Enclosure Dimensions (80-0006R)



Figure 1-3: Three Module System Enclosure Dimensions (80-0007R)

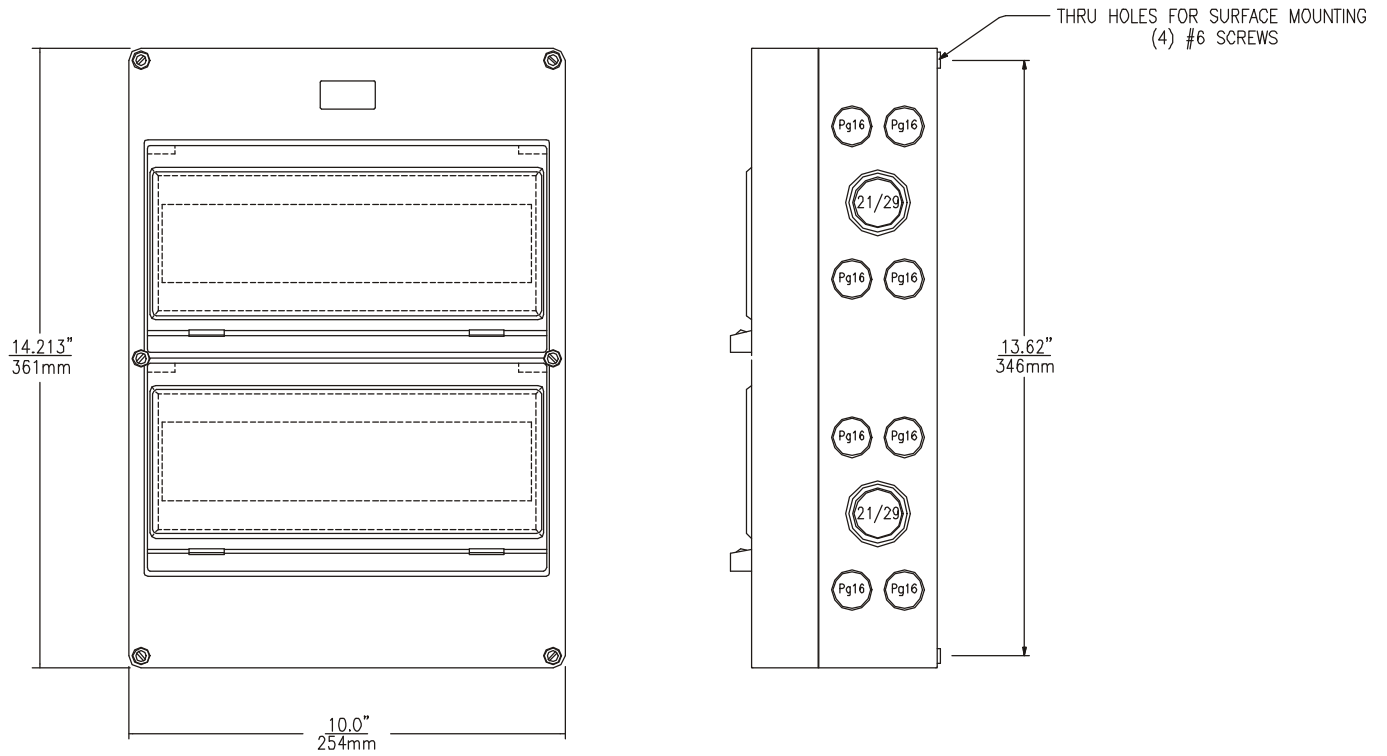

Figure 1-4: Six Module System Enclosure Dimensions (80-0008R)

ELECTRICAL INSTALLATION

Field wiring required for a detection system includes connection of AC power, connection of two conductor cable between the receiver and the sensor/transmitter, and connection of the battery back-up unit if it was purchased with the system. ATI does not supply an AC power cord with the system. A 25 foot length of 2 conductor interconnect cable is supplied for connection of the sensor/transmitter to the receiver. Longer lengths up to 1000 feet may be used when required.

Single point detection systems are supplied with the power supply, receiver, and optional horn factory wired as shown in Figure 1-5 below.

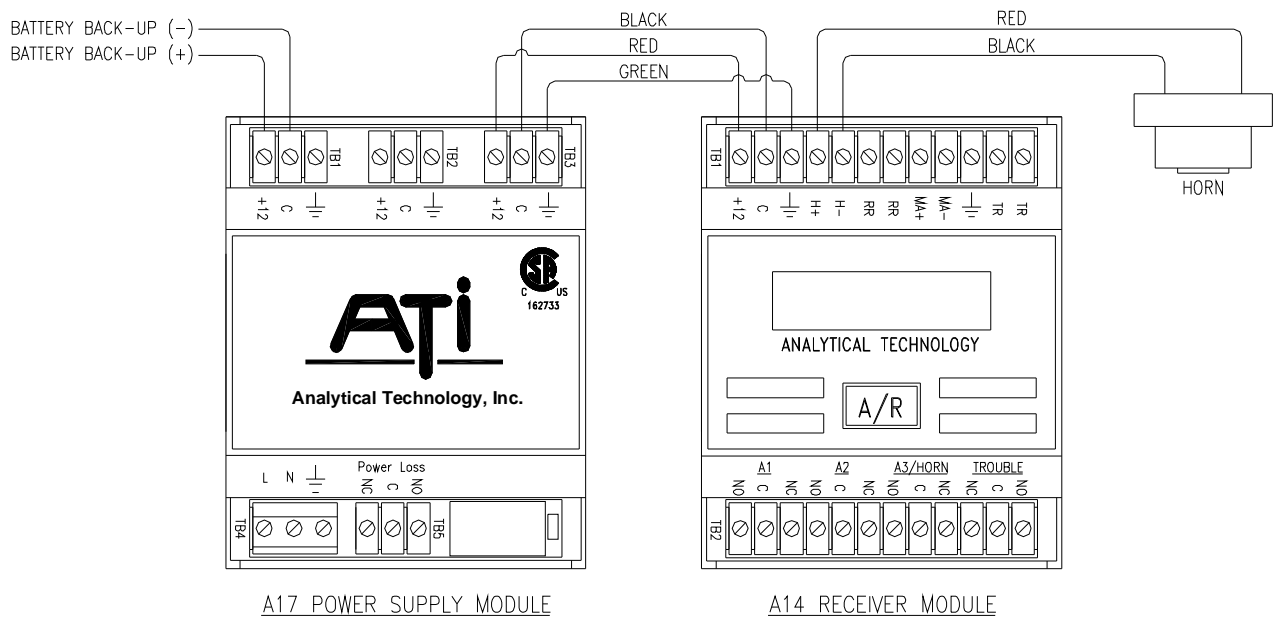

Figure 1-5: Single Point Receiver Internal Wiring (ATI-032)

Figure 2-2 in section 2 of this manual shows a detailed terminal wiring drawing for the Receiver module. Figure 3-1 in section 3 shows a detailed terminal wiring drawing for the power supply module.

A **GasSens** gas detection system will always contain an A14 Receiver and an A11 Sensor/transmitter. Normally, an A17 Power Supply module will also be included, and an A19 Battery Back-up Unit will often be used to provide standby power for the system. Figures 1-8 and 1-9 provide interconnect wiring diagrams for typical single channel systems.

Two point detectors include one power supply and two receivers. These systems are shipped factory wired as shown in Figure 1-6 below.

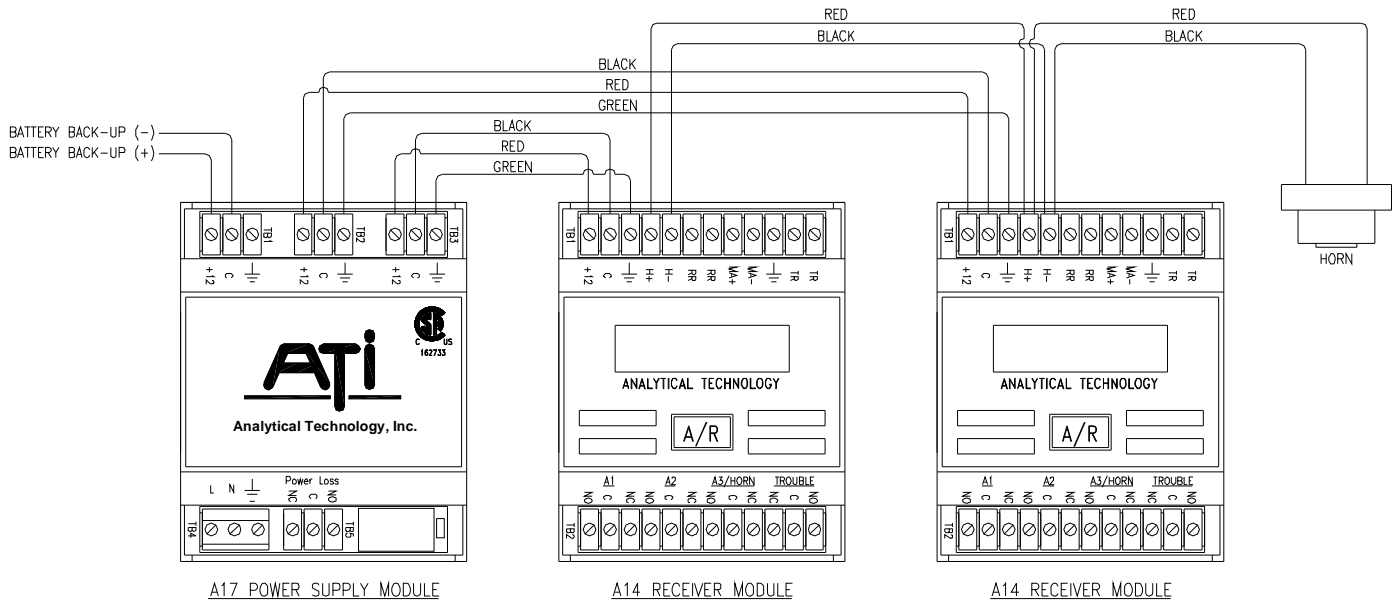

Figure 1-6: Dual Point Receiver Internal Wiring, (ATI-033)



Figure 1-7: Four Point Receiver Internal Wiring (ATI-075)

Multipoint systems supplied in “Large” type enclosures use a 65 watt power supply located in the top of the enclosure. This power supply is designed to power up to 12 of the A14 receiver modules. Figure 1-8 shows typical wiring for this type of system.



Figure 1-8: 65W Power Supply to A11 Wiring Diagram (ATI-0544)

Sensor/transmitters contain two 2-position terminal blocks, one for receiver connection and one for connection of the Auto-Test generator. Connection of the two wires from the receiver are not polarity sensitive. These wires can be hooked up without regard to terminal position. **Connection of the generator is polarity sensitive.** The generator will not function unless connected properly. Sensor/transmitters supplied with the generator from the factory will be factory wired. Adding a generator to an existing unit requires the installer to be sure that generator wiring follows the diagram in Figure 1-8 below.

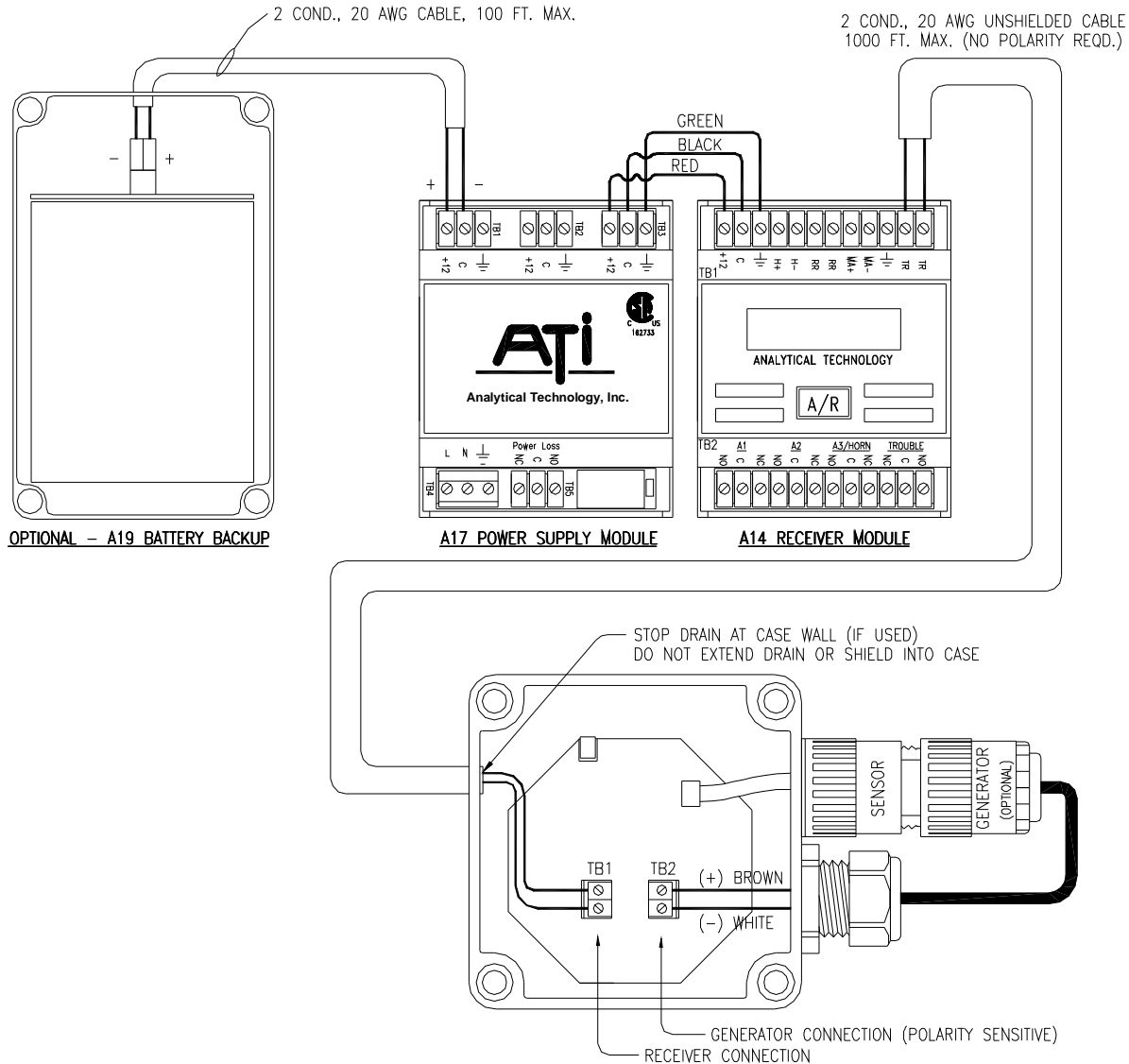

Figure 1-9: Typical System Wiring, Nema-4 Transmitter Version (ATI-034)

CAUTION: Be very careful when removing the knockouts on the sensor/transmitter enclosure. A small bladed screwdriver tapped firmly in the knockout recess is all that is necessary. Do not drive the screwdriver blade into the transmitter enclosure or it may strike the circuit board and cause component damage.

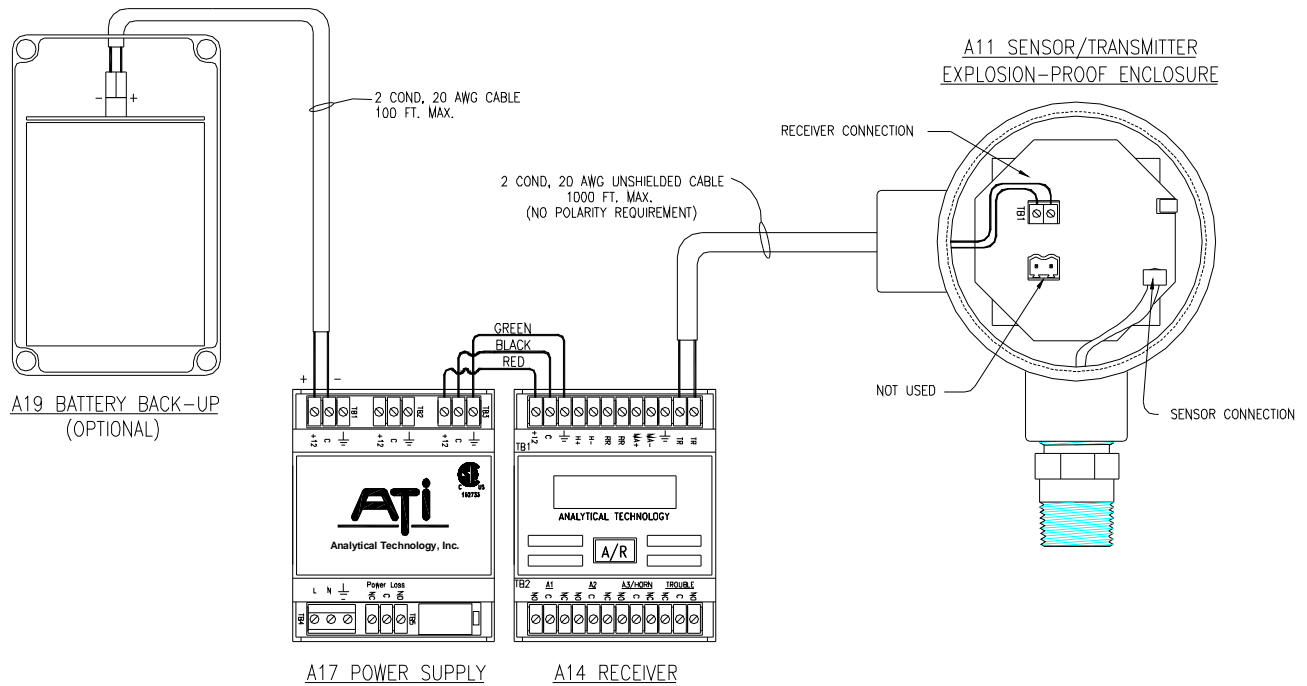

Figure 1-10: Typical System Wiring, Explosion-proof Transmitter Version (ATI-076)

The remainder of this manual is divided into sections that describe each component of the system. Mechanical and electrical installation are the only requirements to provide a workable system. Power supply modules and battery back-up units require no adjustments. Receiver modules are factory set to the range specified on the order, and alarm setpoints will be set to default values unless otherwise specified on the order. Sensor/transmitters are factory calibrated, and should require no adjustments when placed in service. Calibration can be checked if desired according to the instructions in the Sensor/transmitter section of this manual.

Normal operation of the system is done using the switch on the Receiver module. The "Operation" portion of the Receiver section (section 2) should be read and understood before placing the detection system into operation.

RECEIVER MODULE

Introduction

Series A14 Receivers provide the user interface to the gas detection system. Each receiver is connected to a series A11 sensor/transmitter with a 2 conductor cable, and displays information on the gas concentration in the sensor area. Receivers are powered by a separate 12 VDC power supply (part no. 00-0055) supplied as part of the system, or by a power supply furnished by the user (12 VDC only).

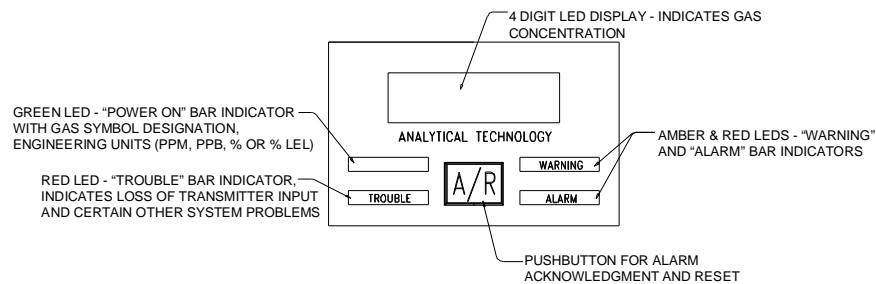

Figure 2-1: Front Panel Controls & LEDs (0109PM)

Receiver modules also include the following standard features:

1. Three SPDT alarm relays, switch programmable for operating configuration.
2. One SPDT trouble relay, for remotely indicating that the TROUBLE alarm is activated.
3. Isolated 4-20 mA output signal proportional to gas concentration.
4. Isolated remote reset input terminals for remote alarm acknowledgment.
5. Power for operation of an A11 sensor/transmitter located up to 1000 feet away.

Receivers are housed in a compact noryl case designed for mounting to a 35 x 7.5 mm DIN rail. The rails are supplied in standard ATI system enclosures, or can be supplied by a system integrator as part of a custom panel arrangement. A spring clip on the back of the enclosure holds the module to the rail. To remove from a rail, slide a thin bladed screwdriver through the black loop at the top of the module and pull outward until the module releases from the rail. To mount to the rail, reverse the procedure. When mounting, slide the bottom of the module against the bottom of the rail before extending the spring clip.

Electrical Connection

Electrical connections to the receiver are made to two pluggable terminal blocks as shown in Figure 2-2. Transmitter connections must be made at the time of installation, while power and horn connections are factory wired when the receiver is part of a complete system. Connections should be made and checked before power is applied to the module. Never connect or alter connections while power is on.

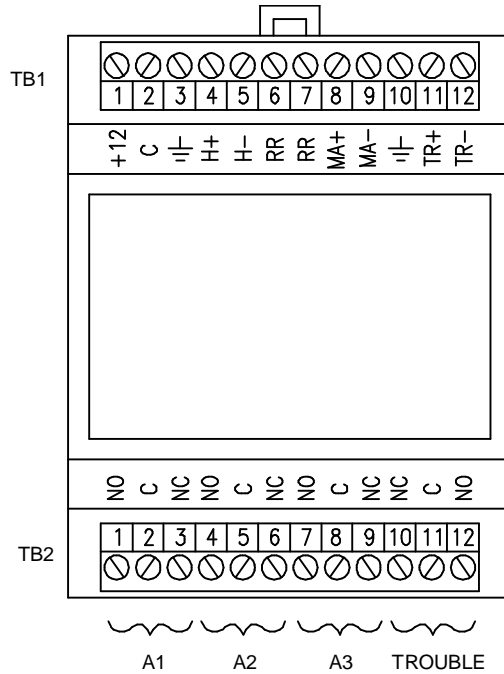

TB1

- 1: +12 Module Power positive (12 VDC)
- 2: C Module Power Common
- 3: Earth Ground (REQUIRED)
- 4: H+ Audible Horn positive
- 5: H- Audible Horn negative
- 6: RR Remote Reset
- 7: RR Remote Reset
- 8: MA+ 4-20 mA output positive
- 9: MA- 4-20 ma output negative
- 10: Earth Ground
- 11: TR Transmitter Input
- 12: TR Transmitter Input

TB2

- 1: A1 NO Alarm 1 normally open contact
- 2: A1 C Alarm 1 common
- 3: A1 NC Alarm 1 normally closed contact
- 4: A2 NO Alarm 2 normally open contact
- 5: A2 C Alarm 2 common
- 6: A2 NC Alarm 2 normally closed contact
- 7: A3 NO Alarm 3 normally open contact
- 8: A3 C Alarm 3 common
- 9: A3 NC Alarm 3 normally closed contact
- 10: TROUBLE NC trouble normally closed contact
- 11: TROUBLE C Trouble common
- 12: TROUBLE NO Trouble normally open contact

NOTE: Relay contact designation is shown for relays in normal mode of operation for relays A1, A2 and A3. If fail-safe relay operation is selected, NO and NC designations are reversed for that relay. The TROUBLE relay is set to fail-safe operation at the factory, and the designation shown above is for the trouble relay in fail-safe mode.

Figure 2-2: Receiver Module Terminals (ATI-029)

CAUTION: Receiver modules **MUST** be connected to a secure earth ground. Terminal 3 of TB1 in Figure 2-2 above must be connected to the earth ground terminal of ATI's power supply module as shown in the connection diagram in Figure 1-3. If the user is providing another 12 VDC supply, be sure that the receiver is properly grounded.

Factory Configuration

All receivers are identical except for the gas symbol attached to the green power LED. Operating range, alarm relay configuration, display intensity, and Auto-Test activation are selectable using 4 banks of DIP switches located on the configuration circuit board inside the module.

Receivers are factory configured for the operating range specified on the customer order. If the system is ordered with the Auto-Test option, this is also factory configured. Factory configuration of the relays is as follows:

Relay 1 - Configured to trip at the Warning setpoint and set for normal, non-latching operation.

Relay 2 - Configured to trip at the Alarm setpoint and set for normal, latching operation.

Relay 3 - Configured to trip at the Alarm setpoint and set for normal, latching operation.

Alarm Delay - Configured for 2 second delay.

Warning and Alarm setpoints are factory set to standard values depending on the operating range. Except for oxygen systems, alarms are set to activate above the setpoints. Oxygen alarms are set to activate below the setpoints.

The LED display will operate in either normal or high intensity mode. Normal mode is the factory default setting, and is used when receivers are located indoors or in shaded areas. High intensity mode is selected when receivers will be mounted outdoors. In high intensity mode, the LED display can be read in direct sunlight.

Configuration Switches

Figure 2-3 indicates the location of each bank of DIP switches on the configuration P.C. board and Figure 2-4 provides a description of the function of each switch on each bank.



Figure 2-3: Configuration Board Switch Location

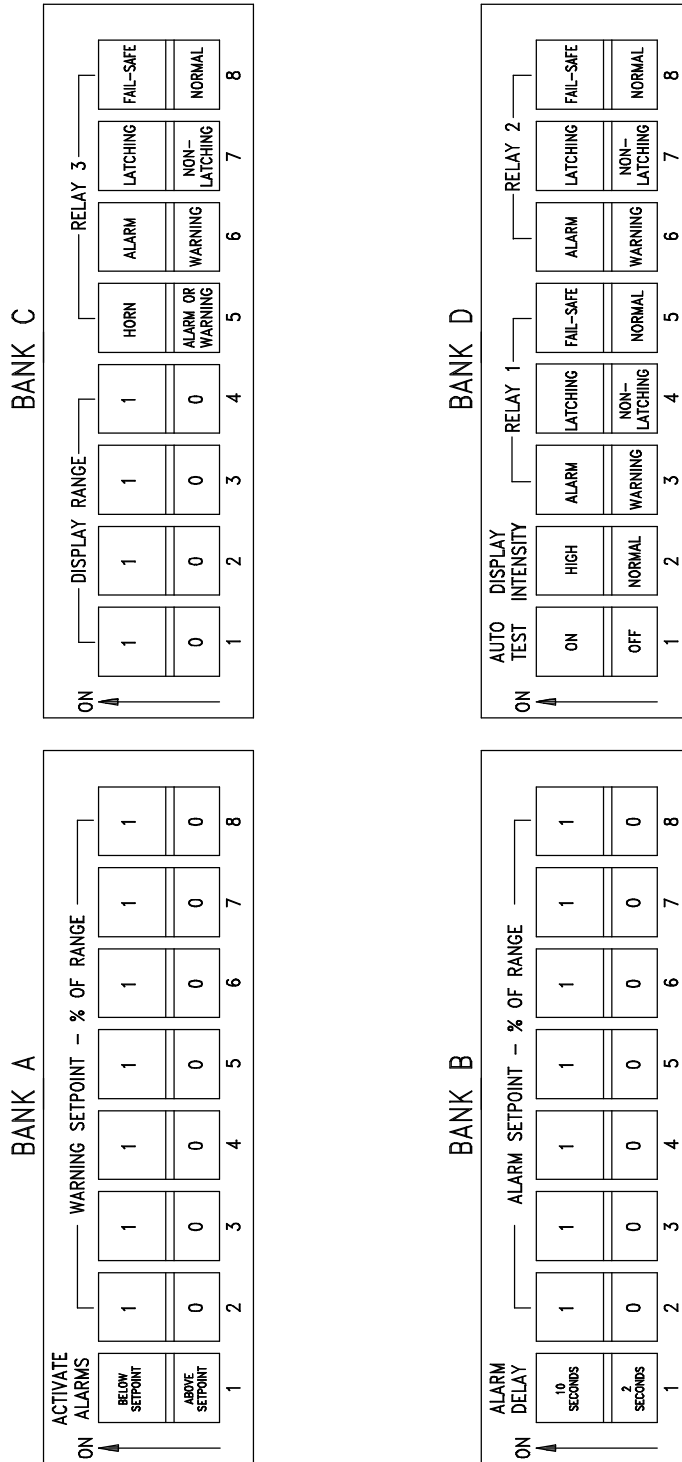

Figure 2-4: Configuration Switch Functions (0110PM)

Setpoint Selection

The operating range and the Warning and Alarm setpoints can be changed, if desired, by using the configuration switches identified in Figure 2-4. The Warning setpoint is set using switches A2-A8 and the Alarm setpoint is set using switches B2-B8. A binary number is used to select setpoints as a percent of operating range. For example, if you have a receiver range of 0-10 PPM and want to adjust a setpoint for 3 PPM, set the appropriate DIP switches to the binary number for 30% from Table 2-1 below. Switches can be set using the tip of a ball point pen or other tool with a small point on one end. Switch are two position, up indicating 'on' or a value of '1' and down indicating 'off' or a value of '0'.

TABLE 2-1

%	SWITCH POS.	%	SWITCH POS.	%	SWITCH POS.
5	0000101	37	0100101	69	1000101
6	0000110	38	0100110	70	1000110
7	0000111	39	0100111	71	1000111
8	0001000	40	0101000	72	1001000
9	0001001	41	0101001	73	1001001
10	0001010	42	0101010	74	1001010
11	0001011	43	0101011	75	1001011
12	0001100	44	0101100	76	1001100
13	0001101	45	0101101	77	1001101
14	0001110	46	0101110	78	1001110
15	0001111	47	0101111	79	1001111
16	0010000	48	0110000	80	1010000
17	0010001	49	0110001	81	1010001
18	0010010	50	0110010	82	1010010
19	0010011	51	0110011	83	1010011
20	0010100	52	0110100	84	1010100
21	0010101	53	0110101	85	1010101
22	0010110	54	0110110	86	1010110
23	0010111	55	0110111	87	1010111
24	0011000	56	0111000	88	1011000
25	0011001	57	0111001	89	1011001
26	0011010	58	0111010	90	1011010
27	0011011	59	0111011	91	1011011
28	0011100	60	0111100	92	1011100
29	0011101	61	0111101	93	1011101
30	0011110	62	0111110	94	1011110
31	0011111	63	0111111	95	1011111
32	0100000	64	1000000	96	1100000
33	0100001	65	1000001	97	1100001
34	0100010	66	1000010	98	1100010
35	0100011	67	1000011	99	1100011
36	0100100	68	1000100	100	1100100

Range Selection

Display range selection is made using binary numbers to represent the full scale operating range for the receiver. Table 2-2 provides the proper switch settings for the ranges available on each receiver. Range selection is made using switches C1-C4. The 4-20 mA output signal is proportional to the selected range.

Ranges marked with 'LSD Fixed' indicate that the least significant digit on the display always reads zero.

TABLE 2-2

DISPLAY RANGE	SWITCH SETTINGS	DISPLAY RANGE	SWITCH SETTINGS
0-1.00	0000	0-50	1000
0-2.00	0001	0-100	1001
0-3.00	0010	0-200	1010
0-4.0	0011	0-500	1011
0-5.0	0100	0-1000	1100
0-10.0	0101	0-1000 LSD Fixed	1101
0-20.0	0110	0-2000 LSD Fixed	1110
0-25.0	0111	0-5000 LSD Fixed	1111

Relay Configuration

Receivers contain 3 SPDT relays that actuate based on gas concentration. Relays can be set to actuate when the gas concentration either goes above or falls below the setpoint. Most gas leak detection applications require alarms to activate above a specific setpoint, but alarms for oxygen deficiency require relay actuation below the setpoints. Switch A1 selects relay operation either above or below setpoints and applies to all relays.

Each relay can be assigned to either the warning or alarm setpoint. As shown in Figure 2-4, switches D3, D6, and C6 configure each relay. When warning is selected, the relay will activate when the warning lamp on the front panel lights. When alarm is selected, the relay will activate with the alarm lamp on the front panel.

Relays may be either Latching or Non-latching. A latching relay activates when gas concentration exceeds the setpoint, but will only deactivate when the **A/R** button is pressed, and then only if the gas concentration has fallen below the setpoint. A non-latching relay will automatically deactivate when the gas concentration falls below the setpoint without **A/R** button being pressed. Selection of the latch/non-latch function uses switches D4, D7, and C7.

Relays may be configured for either Fail-safe or Normal operation. The designation of normal or fail-safe refers to the operation of the relay coil during normal operation. A relay configured for Normal operation will have the relay coil energized when an alarm occurs and de-energized during normal operation. A relay configured for Fail-safe operation has the relay coil energized when conditions are normal and de-energizes when an event occurs. A fail-safe relay will change state if power to the receiver is interrupted.

A short time delay precedes the activation of warning and alarm relays when a setpoint is exceeded. This brief delay of 2 seconds eliminates false alarms due to transients that might be encountered in a particular installation. The 2 second delay is the factory default and is selected with switch B1. A 10 second delay may be selected if required in a specific application. The delay time of either 2 or 10 seconds affects both the warning and alarm indicator lamps and the associated relays.

External Horn Relay

Relay 3 provides an additional configuration option not available on relays 1 or 2. Switch C5 allows relay 3 to be configured for use in activating an external audible horn. When switch C5 is on, relay 3 will operate in parallel with the internal horn. This means that any external horn tied to that relay will sound intermittently when the warning setpoint is exceeded and will go to steady on when the alarm setpoint is exceeded. The relay will deactivate when the **A/R** switch is pressed, silencing the external horn.

Using relay 3 in the horn configuration eliminates the need for additional relay logic to silence an external horn. This can provide significant cost savings in the installation of a complete alarm system.

Display Intensity

The LED display on the receiver will operate in either normal or high intensity mode. The factory setting is normal mode. Switch D2 is used to select high intensity mode for outdoor installations.

OPERATION

Startup

Receiver front panels contain four LED bar indicators and a 4 digit LED display. The digital display indicates gas concentration in either PPM, PPB, or percent. The green LED bar is marked with the gas symbol and units of measurement (PPM, PPB, or %) specified on the customer order. LED bars also indicate WARNING, ALARM, and TROUBLE conditions.

12 VDC power for the receiver is supplied from the power supply module. When power is first applied, the LED display will turn on and will step through three information displays. The first number displayed is the full scale range. A 0-10 PPM unit will be indicated by "10.0" on the display. After 3 seconds, the display will indicate the warning setpoint, the concentration at which the warning relay will activate, with the WARNING lamp illuminated. After 3 seconds, the display will indicate the alarm setpoint, with the ALARM lamp illuminated. At the end of this sequence, the display will begin to indicate gas concentration. However, all alarm functions will be inhibited for 5 minutes while the system is allowed to stabilize. This is indicated by WARNING and ALARM lamps flashing in an alternating pattern. During this period, alarms will not function, but the display will indicate the presence of any gas that might be in the area of the sensor. Normally, the display will spike when power first comes on, and will slowly recover to zero over the 5 minute period in which alarms are inhibited.

NOTE: Sensors may require up to 12 hours to stabilize after power up.

Alarm Acknowledge and Reset

The front panel of the receiver contains one button, marked **A/R**, which is used for a number of different functions. When the receiver is in normal operation, a gas leak that exceeds the warning setpoint will cause the WARNING indicator to flash and the internal horn to sound intermittently. If the alarm setpoint is exceeded, the ALARM indicator will flash and the horn will sound steadily. Pressing the **A/R** button the first time will silence the audible horn, and will change the WARNING and ALARM indicators from flash to steady on. The indicator lamps will remain lit until the gas condition has cleared. The WARNING indicator will automatically shut off when gas concentration falls below the setpoint, but the ALARM indicator will remain lit. Pressing the button after the alarm condition has cleared will reset the ALARM indicator.

Operation of the individual relays depends on the configuration selected for each one. As shipped from the factory, relay 1 will energize when the WARNING indicator lights and will automatically reset when the gas condition clears and the WARNING indicator shuts off. Relays 2 and 3 are configured to energize and latch when the ALARM indicator lights. These relays will reset when the **A/R** button is pressed to reset the ALARM indicator. Changes in the relay configuration switches will alter this operational sequence.

Trouble Alarm and Relay

Receivers contain a TROUBLE indicator and an associated SPDT relay. The trouble alarm will be activated if the transmitter cable is broken or shorted, or if electronic component failure in either the transmitter or receiver causes a loss of digital input. If these conditions occur, the TROUBLE indicator will light, the horn will sound intermittently, and the trouble relay will change state. Note that the trouble relay is a fail-safe relay. Under normal conditions, the coil of this relay is energized, and it de-energizes when a trouble alarm occurs. The trouble relay will also change state if power fails.

For systems supplied with the Auto-Test option, the TROUBLE lamp will also indicate the failure of a sensor to respond to the gas test that occurs automatically every 24 hours. Should this type of failure occur, the TROUBLE indicator will flash, the trouble relay will change state, and the audible horn will activate. Pressing the **A/R** switch will silence the horn, but the lamp and relay cannot be reset for at least 10 minutes. The flashing TROUBLE light indicates that the sensor and gas generator should be tested for proper operation using the manual Auto-Test. If the sensor does not respond, the system should be tested using calibration or test gas as described in the sensor/transmitter instructions. Pressing the **A/R** button resets the trouble relay and indicator.

Auto-Test Function (Optional)

ATI's optional Auto-Test feature is a valuable tool for verifying the proper operation of a gas detection system while saving manpower normally required for routine testing. Auto-Test is an electrochemical gas generator fixed to the gas sensor and controlled from the receiver. Every 24 hours, the receiver automatically activates the gas generator and monitors the output of the gas sensor. When the sensor responds normally, the generator is shut off and the system returns to normal operation. With this feature in place, operation of every gas sensor is verified daily. Manual testing is reduced to periodic calibration every 3-12 months, or when the receiver indicates that a sensor has not passed its normal test.

While an Auto-Test is in progress, the alarm relays are inhibited. This is indicated by the alternating flash pattern on the WARNING and ALARM indicators used during the 5 minute power on delay. Typically, an Auto-Test will progress only a few minutes before the sensor begins to respond. The actual time varies depending on the gas. A chlorine test normally takes less than 30 seconds while a sulfur dioxide test can take as long as four minutes. Alarm relays will remain inhibited for 10 minutes after completion of the test to allow the sensor to recover. The alternating flash pattern will continue during this time.

During the first two minutes of the 10 minute inhibit period, alarms are completely inhibited. The warning and alarm relays will not activate during this period. During the second 8 minute period, the alarms are only partially inhibited. The inhibit flash pattern will continue during the 8 minute period, but the inhibit will be superseded by an alarm should the measured gas concentration exceed 50% of range. This means that alarm protection is partially restored to protect against any major leak during this period. At the end of the 10 minute inhibit period, the alternating flash will end and the unit will return to normal operation.

When the Auto-Test is activated, the generator will turn on for a maximum of 5 minutes. If no sensor response is detected during this time, the generator will turn off and the receiver will wait for 15 minutes before initiating another Auto-Test. If no sensor response is detected after the second test, the trouble indicator will flash, trouble relay will change state, and the horn will sound. The test sequence will be repeated twice more at one hour intervals. If the system passes, alarms will automatically shut off. If it fails, the alarms will continue to be energized. If the trouble alarm has been manually acknowledged and reset between tests, a failure will reactivate the trouble alarm.

NOTE: No Auto-Test will be initiated if the measured gas concentration is above either of the two setpoints. If this condition exists, the receiver will wait for another 24 hours before initiating another Auto-Test sequence.

Lamp and Horn Test

Verification that all digital display segments and alarm indicator bars are functional is done using the **A/R** button to initiate a lamp test. If the detection system includes an internal horn, the horn is also tested as part of the lamp test.

To activate the lamp test, press and hold the **A/R** button for 2 seconds and all front panel indicators will light. The horn will also sound briefly. Immediately release the button and the indicators will return to normal. During this test, alarm relays will not be activated.

Relay Inhibit

Alarm relays in the receiver can be inhibited for up to 4 hours to allow calibration or testing of sensor/transmitters without activating external alarm or control devices. Inhibit is activated through the use of the **A/R** button.

Press and hold the button for approximately 5 seconds. The lamp test will occur first, but continue to hold the button down. Once the lamps have shut off, release the button. The WARNING and ALARM lamps will begin an alternating flash pattern, and, if the receiver is configured for Auto-Test, the flash will switch to the trouble lamp. If you do nothing, the flash will switch between the WARNING/ALARM lamps and TROUBLE lamp twice and then revert to normal operation.

If the **A/R** button is pressed and released while the WARNING and ALARM lamps are in alternating flash, the receiver will go into the relay inhibit mode (if a horn is connected, a quick beep will sound when the inhibit is selected). The WARNING and ALARM lamps will continue their alternating flash for 4 hours or until the **A/R** button is pressed again. During this period, the display will indicate gas concentration, but the relays will not. Transmitters may be calibrated while the inhibit is on without activating external alarms.

Manual Auto-Test

Gas detection systems purchased with the optional Auto-Test generator may be tested by manual activation of the generator from the receiver module. This function will operate only if the Auto-Test configuration switch D1 is 'on'. As with the lamp test and alarm inhibit, access to manual operation of the generator is through the **A/R** button.

Press and hold the button for approximately 5 seconds. The lamp test will occur first but continue to hold the button down. When the lamps have shut off, release the button. The number of hours since the last successful auto-test (automatic or manual) will appear on the display. When the WARNING/ALARM flash is alternating with the TROUBLE flash, you can select manual activation of the generator rather than relay inhibit. Press the **A/R** button when the TROUBLE lamp is flashing (if a horn is connected, a quick beep will sound when the Auto-Test is selected). The green gas indicator will begin to flash, indicating that the generator is activated. The system will go through a normal Auto-Test sequence, exactly the same as the sequence used every 24 hours. If you observe the display, you will see increasing gas values as the sensor begins to respond. Upon completion of a successful test, the horn will sound a single beep. The inhibit will remain on for an additional 10 minutes while the sensor recovers to zero. Should the test be unsuccessful, the TROUBLE lamp will light and the alarm relay and horn will activate. Pressing the **A/R** button will silence the horn, but the alarm cannot be reset for at least 10 minutes after a failure of the manually activated Auto-Test. This period will allow time to manually inspect the sensor to determine the reason for the failure.

If the manual Auto-Test sequence results in a trouble alarm, check the sensor/transmitter. Either the sensor or generator has failed, or the diffusion path between the two is physically blocked. Methods for testing individual gas sensors can be found in specific sensor/transmitter instructions.

Remote Reset

Receivers are provided with input terminals for connection of a remote reset switch. The remote reset input provides horn silence and alarm reset functions using a switch located at a remote point. When receivers are located at sites with telemetry equipment, the remote reset input may be connected to a relay contact in the telemetry system.

The remote reset input accomplishes the same acknowledge and reset functions as the **A/R** button on the front panel. When a switch closure is detected across the remote reset terminals, the detector horn will silence and any latching relays will reset, provided that the gas condition has cleared. The remote reset input will not activate any of the testing or inhibit functions of the receiver.

Analog Output

Receivers provide an isolated 4-20 mA output signal for interface with recorders, data loggers, or computer systems. The span of the 4-20 mA signal is the same as the range of the receiver selected during the receiver configuration. The output will drive loads up to 1200 ohms.

Auto-Test Remote Verification

A14 Receiver modules with a software revision G or higher use the analog output to indicate that a successful Auto-Test has occurred. This allows a recording device to show evidence of the successful test. During an Auto-Test, the 4-20 mA output is locked at 4 mA while the test is in process. If the test is successful, the output will go up by 3% (to 4.48 mA) and will remain at that value until the 10 minute inhibit period is complete, after which it will return to 4 mA.

Deactivating the Auto-Test Function

A14 Receiver modules with software revision G or higher have the capability of temporarily deactivating the Auto-Test function without having to open the module and change the DIP switch that controls this function. This might be necessary if an Auto-Test failure has been traced to a failure of the generator. If proper sensor operation has been verified, the automatic daily activation of the test function can be bypassed until a replacement generator has been installed.

To deactivate the Auto-Test, press and hold the A/R button for a full 15 seconds. As you hold the button, the lamps will turn on and then shut off again. Finally, the green power LED will shut off so that there will be no lamps lit at all. Release the A/R button. After this is done, you will see the green LED periodically flash quickly. This is simply a visual reminder that the Auto-Test has been temporarily deactivated.

To return the receiver to normal operation, press and hold the A/R button until all the lamps and display segments light up. Then let go of the switch and the unit will return to normal operation. Alternately, simply turn the power off and then back on. This will also override the temporary inhibit.

NOTE: If power goes off while the Auto-Test is temporarily deactivated, it will come back on in normal mode. You must again deactivate the Auto-Test again or it will attempt the test 24 hours later.

TROUBLESHOOTING

Receiver modules will normally provide trouble free operation over many years of service. However, should problems arise, a few simple tests can be done to determine if the receiver is functioning properly.

LED display and green gas indicator do not light when power is applied to the system.

1. Check polarity of the power connection at terminals 1 and 2 of TB1. Terminal 1 must be positive and terminal 2 must be negative.
2. With a voltmeter, check the power supply at terminals 1 and 2 of TB1. Input power supply must be 11 to 15 VDC.

Receiver module powers up correctly, but does not respond when test gas is applied to sensor/transmitter.

1. Disconnect transmitter connections at terminals 11 and 12 of TB1. Check the voltage on the terminals with a voltmeter. The voltage should be about 12 VDC.
2. Connect a milliamp meter between terminal 11 and 12 of TB1. The current should measure about 20 mA.

Problems in the receiver module can only be caused by an electronic component failure. In most cases, the simplest solution is to remove the module and install a replacement. Troubleshooting the electronic circuit boards is best handled by trained technician familiar with the circuits. As modules are small and easily shipped, it is best to return defective modules to ATI for service.

Modules failing during the warranty period will be exchanged by ATI with replacement units. Contact the ATI service department for assistance.

RECEIVER MODULE PARTS LIST

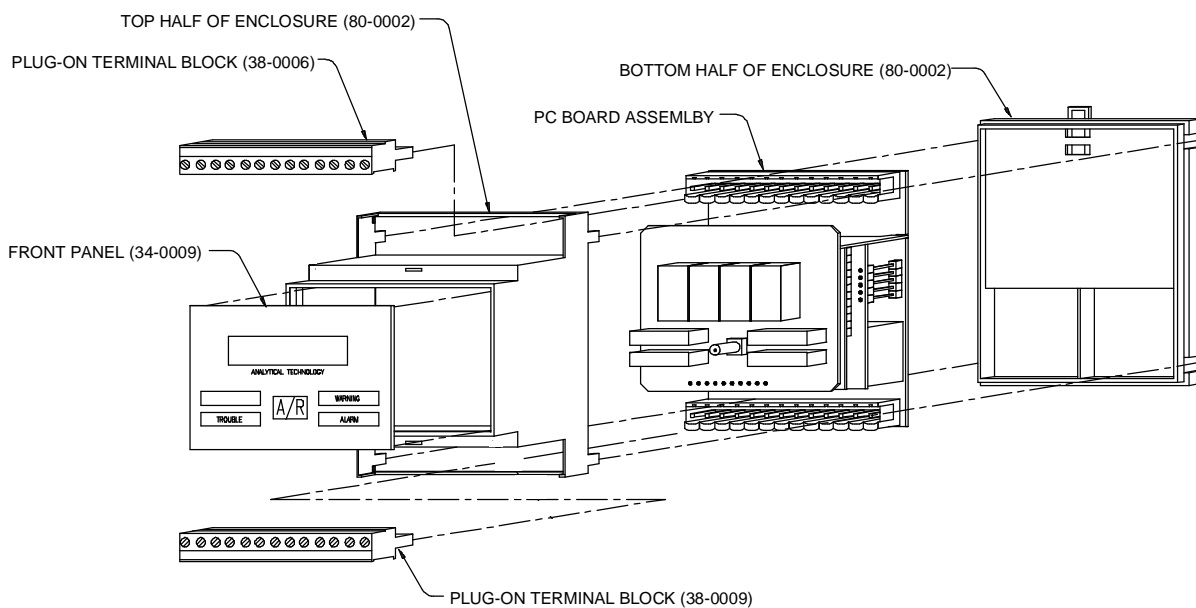

<u>Part Number</u>	<u>Description</u>
00-0056	Complete receiver module (Specify Gas)
80-0002	Module enclosure (top and bottom)
34-0009	Front panel
38-0009	Relay terminal block plug, 12 position
38-0006	DC terminal block plug, 12 position

A17 UNIVERSAL POWER SUPPLY

The power supply module used in the **GasSens** system (part #00-0055) is a self-adjusting supply that will accept the AC power provided in virtually every country in the world. Any AC (50-60 Hz.) or DC voltage from 85 volts to 270 volts can be connected to the power input terminals on TB4. There are no adjustments of any kind required.

The output of the power supply is a regulated 13.7 VDC. There are 3 sets of DC terminals at the top of the module for connection to receivers and external battery back-up unit. This voltage permits float charging of a an optional separate 12 volt lead acid battery for detector system back-up.

Power supply modules are rated for 1 ampere output, and will deliver higher current for periods. Each optional receiver module draws a maximum of 300 mA, and will normally draw about 125 mA. The optional external battery back-up unit can draw up to 750 mA for a few hours if the battery is deeply discharged, which will drop sharply as the battery approaches full charge. The audible horn draws less than 10 mA average current, and an optional strobe will draw approximately 400 mA when activated.

The power supply is internally fused at 2 Amps. The fuse is not user replaceable. (Note: Only Qualified Service Personnel will replace the fuse, using the same type and rating as indicated on the fuse.)

The power supply has a power-on indicator LED and provides a SPDT relay to indicate power failure. The relay coil is energized by power from the input power terminals and will de-energize if power is lost. This relay is convenient for input to telemetry systems to indicate loss of power at a remote site.

Mounting of power supply modules is done by clipping them to a standard 35 x 7.5 mm DIN rail. A spring loaded clip holds the module to the rail and is used for mounting and removal. From the front, the clip is seen as a black loop at the top rear of the module. To remove from a rail, place a small screwdriver into the opening in the black loop and pull outward until the module releases from the rail. Reverse the procedure to mount the module.

CAUTION

The power supply module is sealed, and the seal should not be broken. Never attempt to disassemble or service the power supply module. Service on this module should only be done only by a qualified service technician familiar with the circuit design and equipped with the proper service equipment. Severe electrical shock may result from touching internal components with input power applied.

Figure 3-1 provides detailed information on the terminals provided on the power supply. All terminal blocks are plug-in type, and can be easily unplugged should removal of the module be necessary.



- | | | |
|---|---|--|
| <p><u>TB1</u>
(12V Battery only)</p> <p>1: +12 External Battery (+)
2: C External Battery (-)
3: Earth Ground</p> | <p><u>TB2</u></p> <p>1: +12 Receiver Module (+)
2: C Receiver Module Common
3: Earth Ground</p> | <p><u>TB3</u></p> <p>1: +12 Receiver Module (+)
2: C Receiver Module Common
3: Earth Ground</p> |
| <p><u>TB4</u></p> <p>1: L AC power hot (85-255 VAC)
2: N AC power neutral
3: AC power ground (earth ground REQUIRED)</p> | <p><u>TB5</u></p> <p>1: NC Power failure normally closed contact
2: C Power failure common
3: NO Power failure normally open contact</p> | |

NOTE: AC power input must be properly earth grounded for safe operation. 220 VAC power without a neutral line may not be used with this power supply.

Figure 3-1: Power Supply Terminal Connections (ATI-030)

POWER SUPPLY PARTS LIST

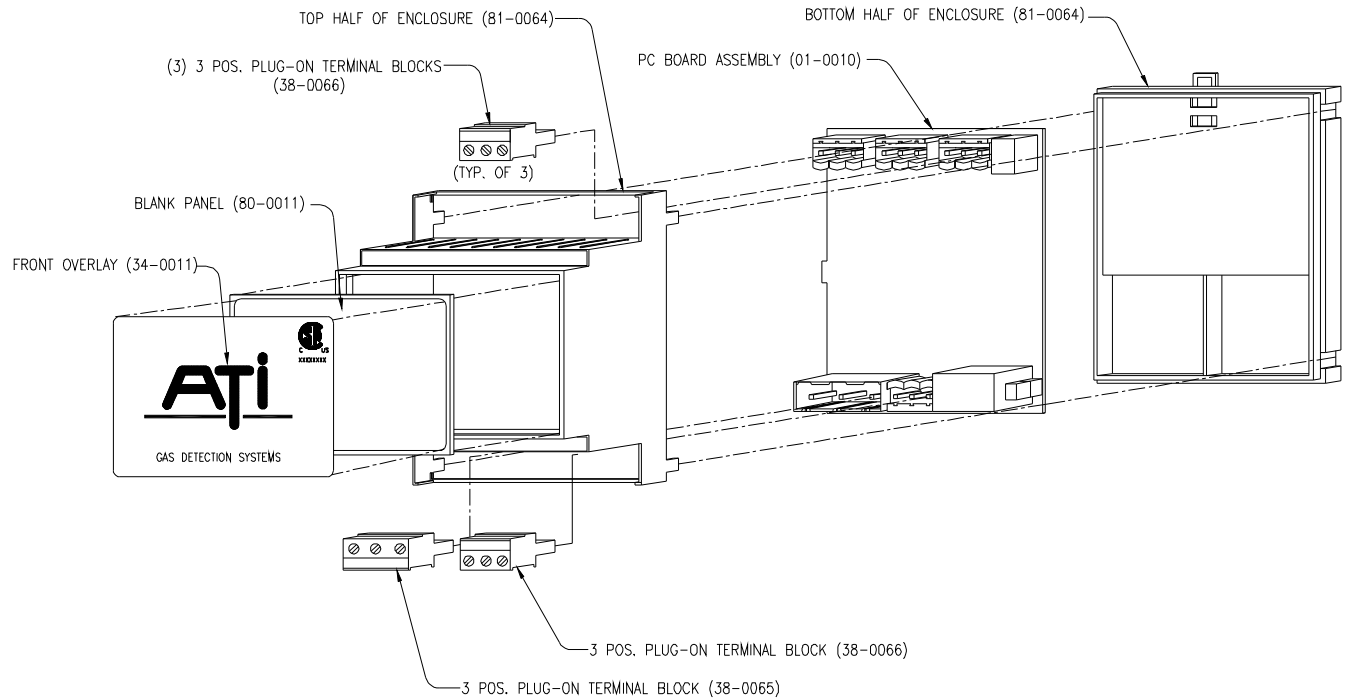

<u>Part Number</u>	<u>Description</u>
00-0055	Complete power supply module
81-0064	Module enclosure (top and bottom)
34-0011	Front overlay
38-0065	AC power terminal block plug, 3 position
38-0066	Power failure relay & DC terminal block plug, 3 position

OPTIONAL EQUIPMENT

Battery back-up units for **GasSens** detection systems (part #00-0057) are separate components housed in a NEMA 4X wall mount enclosure. Back-up units include a 4 ampere-hour sealed lead acid battery with a control circuit attached to the battery terminals. The battery is held in place on an aluminum bracket fixed to the plastic enclosure.

Installation

Figure 4-1 shows the dimensions of the battery back-up unit and the mounting hole centers. Two conduit hubs are supplied with the unit, one for use on the battery back-up enclosure and one for use on the receiver enclosure. **When mounting the battery back-up unit, be careful to hold the module securely when screwing the enclosure in place. The battery is heavy and could cause injury to feet if it should fall directly on them.** The battery and attached circuit board are held in place with a wire tie. Should you wish to remove the battery, the wire tie must be cut. When replacing the battery, secure with a new wire tie. Replacement batteries from ATI are supplied with the proper wire tie.

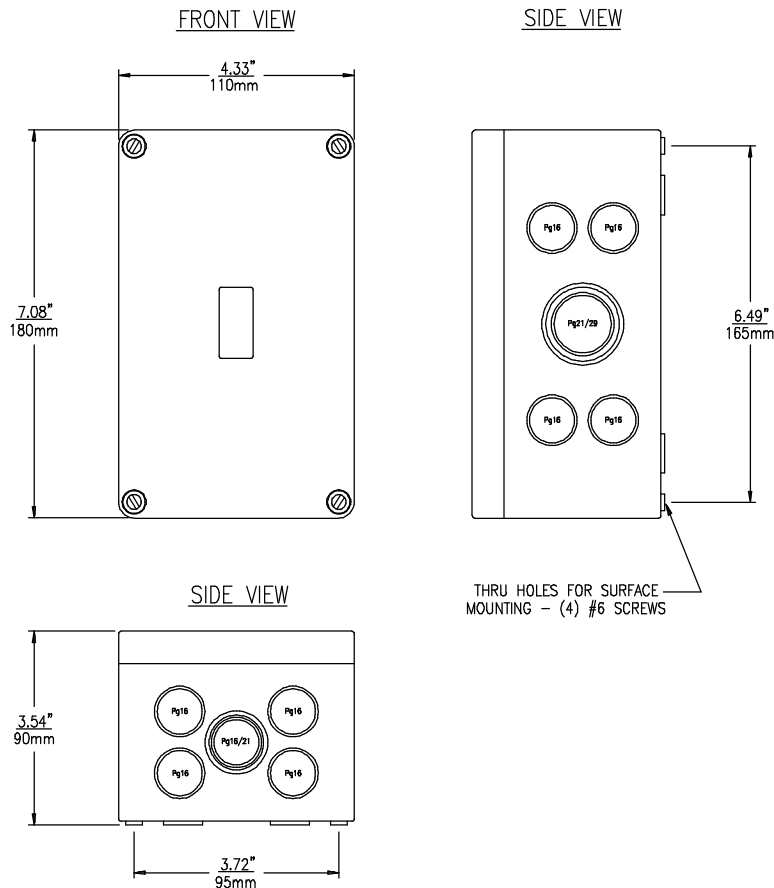

Figure 4-1: Battery Backup Enclosure Dimensions (80-0008)

Electrical connection is made between the battery back-up unit and the power supply module. The circuit board mounted on the battery contains a 2 position plug-in terminal block marked plus and minus. The plus terminal is connected to terminal B+ of the power supply and the minus terminal is connected to B- of the power supply.

Operation

When power is applied to the power supply module, a relay on the battery back-up circuit board energizes and places the battery back-up into operation. There are no user adjustments in the battery back-up unit. If the battery is not fully charged, the power supply will begin supplying charge current to the battery, and will float charge the battery as long as the power supply is on.

Should the power supply lose its input power, the battery back-up will immediately supply power to receiver modules to maintain detection system operation without interruption. The back-up period will vary depending on whether the detector is single channel or two channel, on whether displays are in normal or high intensity mode, and on how many relays are configured for fail-safe operation. The minimum period expected for a single channel system is 12 hours and for a two channel system is 6 hours. Normally, the back-up period is twice as long as the minimums.

The circuit board attached to the battery serves two functions. First, it regulates the charging current to the battery to a maximum of 0.75 amps. This prevents possible damage to the battery due to an excessively high charge current. Second, it isolates the battery from the detection system when the battery voltage falls below 10 volts. This is done through a relay, and protects the battery against damage caused by very deep discharge.

The isolation relay that protects against deep discharge will also protect the battery against an external short circuit of the wires connected to the battery. If a short occurs, the relay will immediately open, protecting the battery and limiting the current that the battery will deliver.

Removal from Service

The relay that isolates the battery when the 10 volt level is reached is energized as soon as power is applied to the power supply module. Once energized, the coil current is supplied from the battery if needed. If the gas detection system supported by the battery back-up is started up for testing and then shut down, the battery back-up relay should be de-energized manually. Otherwise, the relay coil will continue to draw power from the battery until the 10 volt level is reached. While this will not cause damage, it means that the battery will be discharged when the detection system is started up again.

To de-energize the relay, slide the control circuit board off the battery terminals briefly and then slide it back on. As soon as the battery connection is broken, the relay coil will drop out, and will not energize until power is applied to the power supply module in the system. This procedure is recommended any time the detection system is to be shut down for more than a few days.



BATTERY BACKUP PARTS LIST

<u>Part Number</u>	<u>Description</u>
00-0057	Complete battery back-up unit
01-0011	Battery back-up circuit board
80-0009	NEMA 4X enclosure (top and bottom)
48-0010	Battery bracket
29-0002	Battery, 12 V, 4 A-H
92-0022	Self-tapping screws, (Pkg. Of 2)
44-0017	Pg 16 to 1/2" NPT conduit hub
44-0018	Pg 16 Seal Ring (required for NEMA-4X rating on hub)

STROBE PARTS LIST

<u>Part Number</u>	<u>Description</u>
35-0002	Red Strobe, 12-80 VDC
35-0005	Red Strobe, 120 VAC
35-0004	Amber Strobe, 12-48 VDC
35-0006	Amber Strobe, 120 VAC

STROBE LIGHT

The accessory alarm indicating strobe light (part number 35-0002) available for use with the **GasSens** alarm system is a weatherproof high-intensity strobe operating from a 12 VDC power source. The strobe can be conveniently mounted on the top or either side of the alarm enclosure using one of the 1/2" NPT hubs supplied with the unit. The bottom of the strobe also contains a 1/2" NPT mounting adapter, so that only a 1/2" pipe nipple is needed to complete the assembly. The necessary nipple is available from most hardware stores or plumbing supply outlets.

For remote applications, the strobe should be mounted to 1/2" conduit, with a junction box nearby for splicing the strobe wires to the interconnect wiring running to the alarm unit. This wiring should be kept separate from AC power wiring to avoid accidental connection of AC power to the strobe, which will damage the lamp.

The 12 VDC power to operate the strobe can be picked up from the power supply module which is part of the alarm unit. Figure 4-2 shows the typical wiring diagram for connection of the strobe. The wiring diagram shows the plus side of the 12 VDC supply brought to the common of the alarm contact, one side of the strobe wired to the normally open (NO) contact, and the other side of the strobe connected to the minus side of the 12 VDC supply. Connection of the strobe lamp directly across the alarm relay will not operate the strobe because alarm contacts are unpowered.

CAUTION: Strobe light connection is polarity sensitive. Check wiring to be sure that the +12 is connected to the red strobe wire.

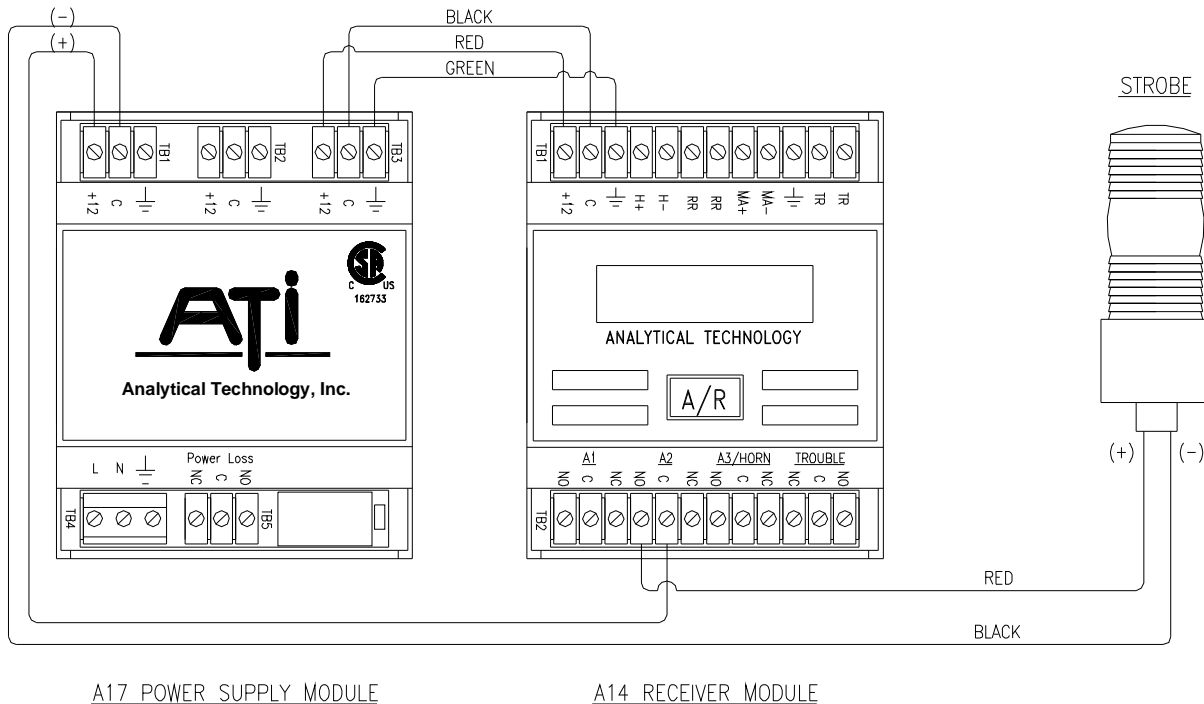

Figure 4-2: External Strobe Light Connections (ATI-0240)

INTRODUCTION

Series A11 sensor/transmitters combine electrochemical gas sensors and an electronic amplifier that transmits gas concentration using a current pulse position technique. When ordered as an option, sensor/transmitters are also supplied with the gas generator that provides the **Auto-Test** automatic sensor testing system.

NOTE: An Auto-Test generator is not currently available for the alcohol Sensor/Transmitter.

Gas sensors are housed in a corrosion resistant plastic housing connected to the transmitter enclosure through a knockout. A short sensor cable with three pin socket connects the sensor to the transmitter circuit board. For hazardous area applications, sensor/transmitters are housed in a cast aluminum explosion-proof enclosure and the sensor is contained in a stainless steel shell with explosion-proof cable seal.

Sensor/transmitters are powered from a current limited 12 volt supply provided by the receiver. **Do not attempt to operate the transmitter from another 12 volt power supply or the transmitter will be damaged.** If you wish to perform a calibration on the bench, use a spare receiver module to power the transmitter. A separate 12 volt supply can be used if the current is limited to a maximum of 20 mA.

INSTALLATION

Sensor/transmitters are surface mounted using screws or bolts as required. Figure 5-1 & 5-2 provides the dimensions for both the standard and explosion-proof transmitters. Standard enclosures will accommodate #6 or #8 screws which are not supplied. For standard transmitters not equipped with Auto-Test, the sensor may be oriented either horizontally as shown in Figure 5-1 or facing downward. For pipe mounting, special 2" pipe mounting brackets are available

Explosion-proof transmitters are mounted to and supported by the explosion-proof electrical conduit used for wiring connections to the transmitter. The sensor orientation may be either horizontal or facing downward, as shown in Figure 5-2. To maintain the explosion-proof integrity of the transmitter, a suitable cable entry seal must be used in accordance with the applicable electrical code.

NOTE: Gas sensors are shipped with a protective plastic cap over the end. This cap should be left in place to avoid damage to the sensor during installation. If the detection systems is to be activated within a few days of installation, the cap should be removed when installation is complete. Otherwise, leave the cap in place the system is to be placed in service. Be sure to leave the protective cap on the sensor if painting is to be done in the area of the sensor.

Installation wiring requires connection of a 2 conductor cable from the receiver. Connection is made at the terminals marked TB1 on Figure 5-4. This connection is not polarity sensitive so you can connect either conductor to either terminal. The cable supplied with the system is unshielded #20 gauge stranded.

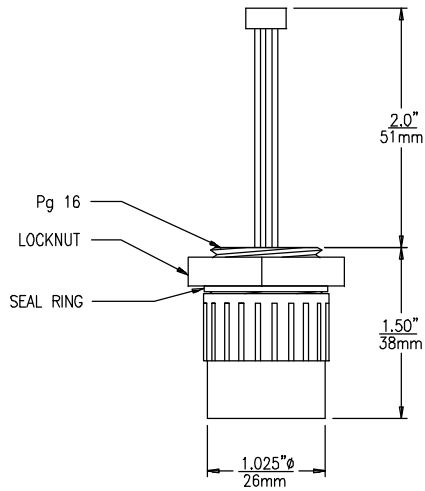
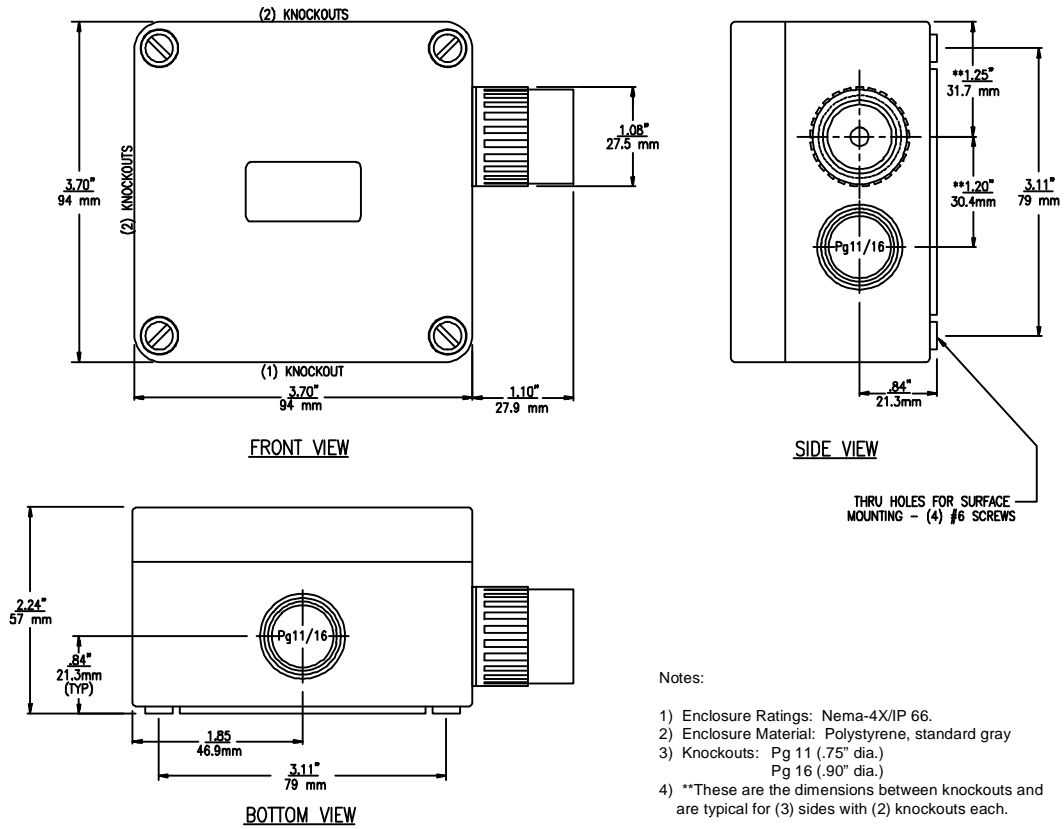

Figure 5-1: Nema-4X Sensor/Transmitter Dimensions (ATI-017, ATI-0169)

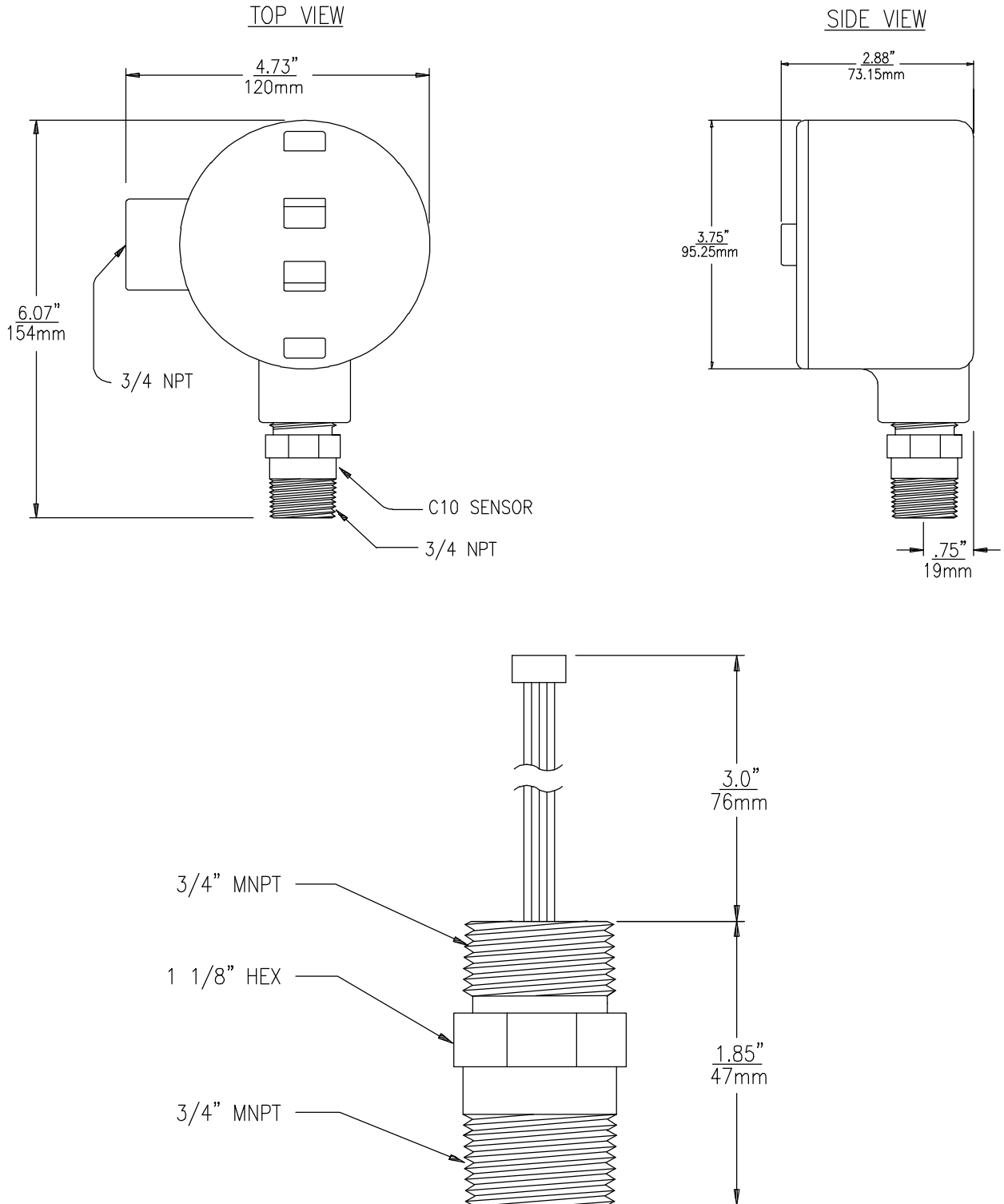

Figure 5-2: Explosion-Proof Sensor/Transmitter Dimensions (ATI-046, ATI-0170)

SENSOR LOCATION

Most alcohol vapors are heavier than air and will tend to accumulate near the floor in a closed room with little air movement. If there is good air circulation in an enclosed area, some alcohol will undoubtedly be carried throughout the area. Alcohol gas sensors should be located one to two feet off the floor in closed storage rooms, but may be located at higher elevations in outdoor areas or where good air flow will quickly mix any leaking gas throughout the space. Outdoor sensor locations require that prevailing wind patterns, likely personnel work areas, and most probable leak sources all be evaluated to determine where sensors will detect leakage with the shortest response time.

INTERFERENCES

The A11-39 sensor/transmitter uses an electrochemical sensor manufactured by ATI. It is designed to measure alcohol gas concentration in air with a maximum of sensitivity and a minimum of interference from other gases.

Unfortunately, electrochemical sensors are not 100% selective and do exhibit response to other gases that may be present in ambient air. Table 5-3 lists the possible interferences that may be encountered when using the alcohol sensor. The table indicates the relative response of the alcohol sensor to 1 PPM of the listed gas, expressed in terms of relative PPM alcohol signal. For example, exposure of the sensor to a gas sample containing 1 PPM of carbon monoxide would produce a signal equivalent to 0.3 PPM of alcohol. Data is based on methanol. Other alcohols may have different responses. Contact ATI for applications involving alcohols other than methanol.

TABLE 5-3

<u>INTERFERENCE</u>	<u>RESPONSE</u>
HYDRIDES (PH ₃)	1.0
NITRIC OXIDE	0.5
CARBON MONOXIDE	0.3
HYDROGEN	0.03

CALIBRATION

Alcohol sensor/transmitters are factory calibrated for the operating range specified on the order, with the calibrated range shown on the calibration tag attached inside the lid of the transmitter enclosure. For critical applications, sensor/transmitters should be calibrated every 3-6 months. When used primarily for high level leak detection, yearly calibration is probably sufficient. Keep in mind that the best calibration sources are generally $\pm 10\%$ accurate, and that a sensor/transmitter will normally change sensitivity by less than 25% over 12 months time.

Calibration of an alcohol sensor/transmitter requires a digital volt meter (DVM), a source of calibration gas, and a calibration adapter for the sensor. Calibration standards for alcohol are not readily available, so field calibration requires the use of an interfering gas in order to simulate the sensor's response to alcohol. Carbon monoxide can serve as a secondary gas standard for field calibrations of alcohol sensor/transmitters. For standard 0-500 PPM alcohol transmitters, a 500 PPM CO standard is recommended.

NOTE: If alarm relays at the receiver are connected to devices that should not be activated during calibration, place the receiver into 'alarm inhibit' as described in the Section 2 of this manual prior to calibrating the sensor/transmitter.

Prior to calibration, remove the cover from the sensor/transmitter enclosure and connect a DVM to the test points shown in Figure 5-4. The same octagonal transmitter circuit board shown in Figure 5-4 will be found in the explosion-proof transmitter. The test points will provide a 0-1.00 VDC signal proportional to transmitter range. For a standard 0-100 PPM unit, 0 PPM is 0.00 volts and 100 PPM is 1.00 volts.

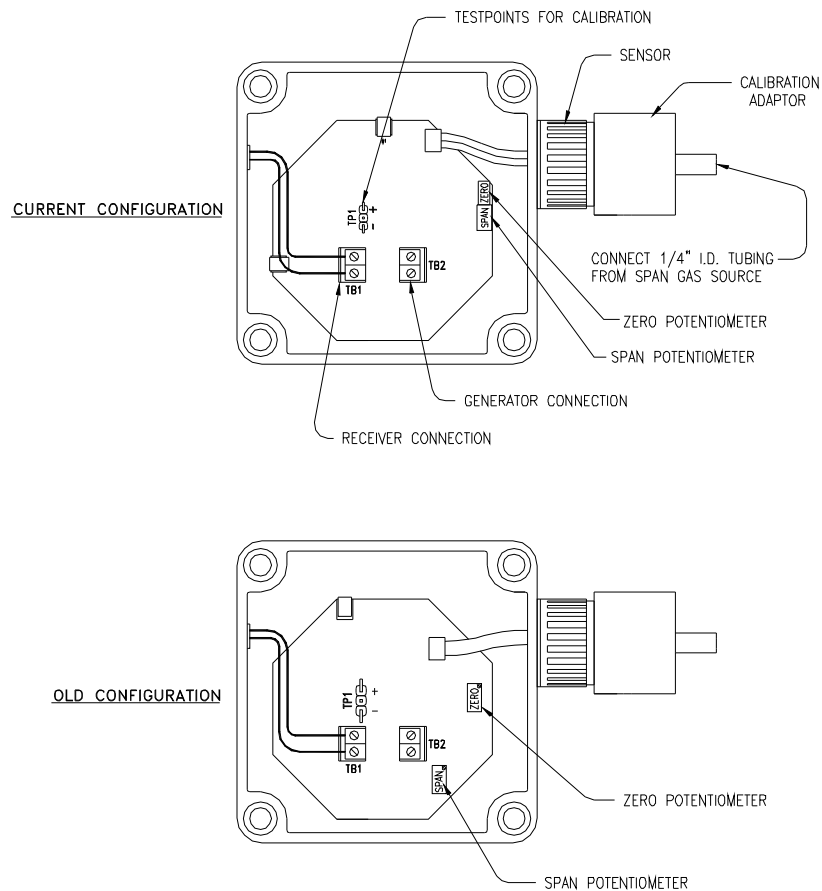

FIGURE 5-4: SENSOR/TRANSMITTER CONTROLS AND TEST POINTS (ATI-096)

TRANSMITTER ZERO

The transmitter zero is adjusted with the sensor exposed to air that contains no alcohol. Generally, the easiest method of zeroing the transmitter is to make the adjustment when you know that the area is free of alcohol vapors. The absence of alcohols can be verified fairly easily by isolating the sensor from the ambient air and observing the test point voltage (or the receiver display, if nearby). Prior to placing the calibration adaptor on the sensor, observe the DVM reading. Slide the calibration adaptor onto the end of the sensor and observe the DVM reading for the next 5 minutes. If alcohol or some interfering gas is in the ambient air, the value on the DVM will begin to decline. If the value remains stable (± 0.02), the sensor is at zero, and the DVM reading can be adjusted to 0.00 ± 0.01 VDC using the zero potentiometer shown in Figure 5-4.

The transmitter can also be set to zero using "zero air" available in cylinders. Zero air cylinders and regulators are available from ATI or from specialty gas suppliers. Connect the zero air cylinder to the calibration adapter and adjust gas flow to 500 cc/min. When the display stabilizes near zero, adjust the zero potentiometer until the display reads 0.00 ± 0.01 VDC.

NOTE: If using the receiver display when adjusting the transmitter zero, place the receiver in the "Inhibit" mode as described in Section 2 of the manual. When in the inhibit mode, the blanking around zero is disabled so that the zero can be set accurately.

TRANSMITTER SPAN

To span the sensor/transmitter, connect tubing from your span gas cylinder to the calibration adapter inlet. Turn on the gas flow and adjust to approximately 500 cc/min. (ATI calibration kits contain fixed flow regulators that automatically provide 500 cc/min. flow). The reading on the DVM attached to the transmitter test points will immediately start to increase. Allow the gas to flow to the sensor for 10 minutes and observe the reading on the DVM. The reading should be relatively stable ± 0.05 VDC. Use the span potentiometer to adjust the DVM to the voltage equivalent to the value of the span gas. The voltage you set will be dependent on the carbon monoxide concentration used to span the transmitter. The proper voltage is calculated as follows:

$$V = 0.33 \times (\text{Span Gas Concentration} \div \text{Transmitter Range})$$

As an example, if your span gas cylinder is marked with a concentration of 500 PPM CO as a surrogate for alcohol and it is used to calibrate a 0-500 PPM sensor/transmitter, the calculation would be:

$$V = 0.33 \times (500 \div 500) = 0.33 \text{ VDC}$$

When the span has been set, turn off the span gas flow and remove the calibration adapter from the sensor. Place the lid back on the transmitter enclosure and tighten the screws to insure the enclosure remains water tight. If the receiver is nearby and the alarm relays were inhibited prior to calibration, press the A/R switch to return the system to normal operation.

SENSOR RESPONSE TEST

While zero and span adjustments are required only periodically, gas sensors should be checked regularly for proper response. For systems not equipped with Auto-Test, manual sensor response testing once a week is recommended. The response check can be done quickly by placing a few drops of alcohol in a plastic container and sliding the container up over the sensor. The alcohol vapor in the container should cause a rapid increase in the transmitter output.

The sensor response test will create a condition where alarm relays may be activated unless they are inhibited as described in the receiver section. To observe the response at the transmitter, it is necessary to connect a DVM to the test points indicated in Figure 5-4. If the receiver is nearby, you may simply observe the digital display on the receiver. If the sensor does not respond, it should be replaced.

SENSOR REPLACEMENT

Electrochemical sensors used in the A11 are warranted for 12 months and generally last 18-24 months. When sensor replacement is required, it can be done easily and quickly. Open the transmitter and unplug the sensor cable from the transmitter circuit board. Unscrew the sensor from the nut on the inside of the enclosure and screw in the replacement sensor. For explosion-proof transmitters, there is no nut, since the stainless steel sensor housing threads directly into the enclosure.

Connect the new sensor to the pins on the transmitter board and replace the transmitter cover. After a new sensor has been connected, allow 12 hours for the new sensor to completely stabilize. Then perform a zero and span as described on pages 4 and 5.

ALCOHOL SENSOR/TRANSMITTER PARTS LIST

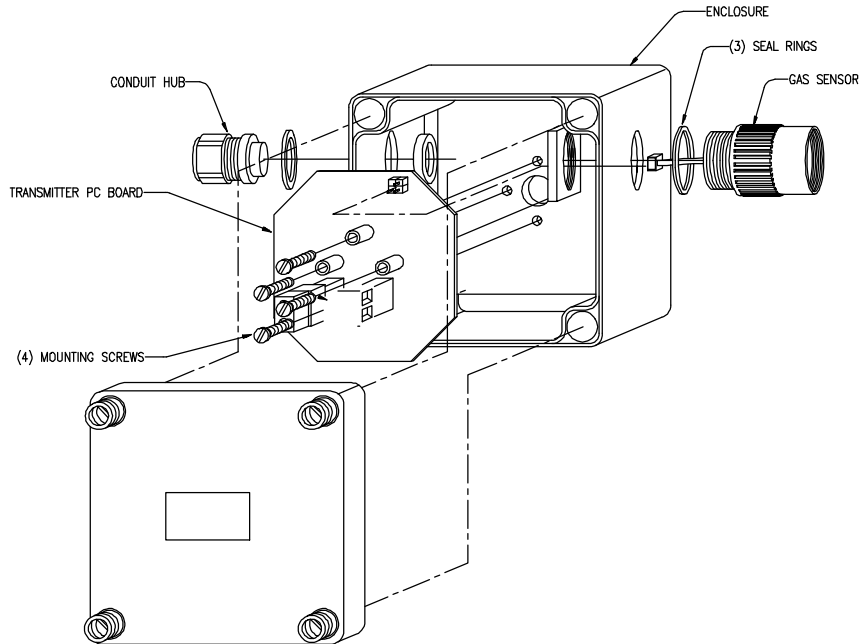

<u>Part Number</u>	<u>Description</u>
00-0732	Complete alcohol sensor/transmitter assembly (includes sensor)
00-0727	Alcohol gas sensor
01-0019	Transmitter circuit board
80-0012	NEMA 4X enclosure (top and bottom)
38-0002	Terminal block plug, 2 position
92-0005	Self-tapping screw (#8 x 1/2")
44-0017	1/2" NPT conduit hub
44-0018	Seal ring (required for NEMA 4X rating on fittings)