

Model A21

Gas Sampling System

Home Office

Analytical Technology, Inc.
6 Iron Bridge Drive
Collegetown, PA 19426

Ph: 800-959-0299
610-917-0991

Fax: 610-917-0992

Email: sales@analyticaltechnology.com

European Office

ATI (UK) Limited
Unit 1 & 2 Gatehead Business Park
Delph New Road, Delph
Saddleworth OL3 5DE

Ph: +44 (0)1457-873-318

Fax: + 44 (0)1457-874-468

Email: sales@atiuk.com

PRODUCT WARRANTY

Analytical Technology, Inc. (Manufacturer) warrants to the Customer that if any part(s) of the Manufacturer's equipment proves to be defective in materials or workmanship within the earlier of 18 months of the date of shipment or 12 months of the date of start-up, such defective parts will be repaired or replaced free of charge. Inspection and repairs to products thought to be defective within the warranty period will be completed at the Manufacturer's facilities in Collegeville, PA. Products on which warranty repairs are required shall be shipped freight prepaid to the Manufacturer. The product(s) will be returned freight prepaid and allowed if it is determined by the manufacturer that the part(s) failed due to defective materials or workmanship.

This warranty does not cover consumable items, batteries, or wear items subject to periodic replacement including lamps and fuses.

Gas sensors carry a 12 months from date of shipment warranty and are subject to inspection for evidence of misuse, abuse, alteration, improper storage, or extended exposure to excessive gas concentrations. Should inspection indicate that sensors have failed due to any of the above, the warranty shall not apply.

The Manufacturer assumes no liability for consequential damages of any kind, and the buyer by acceptance of this equipment will assume all liability for the consequences of its use or misuse by the Customer, his employees, or others. A defect within the meaning of this warranty is any part of any piece of a Manufacturer's product which shall, when such part is capable of being renewed, repaired, or replaced, operate to condemn such piece of equipment.

This warranty is in lieu of all other warranties (including without limiting the generality of the foregoing warranties of merchantability and fitness for a particular purpose), guarantees, obligations or liabilities expressed or implied by the Manufacturer or its representatives and by statute or rule of law.

This warranty is void if the Manufacturer's product(s) has been subject to misuse or abuse, or has not been operated or stored in accordance with instructions, or if the serial number has been removed.

Analytical Technology, Inc. makes no other warranty expressed or implied except as stated above.

TABLE OF CONTENTS

INTRODUCTION.....	3
SPECIFICATIONS	4
INSTALLATION.....	5
Optional Inlet Filter Assembly	8
OPERATION.....	9
Low Flow Alarm.....	9
Power Failure Alarm (12 VAC version only)	9
SPARE PARTS	10

INTRODUCTION

The model A21 is an electrically operated gas sampling system designed to draw air samples from air ducts, vent stacks, enclosed spaces, or other areas where gas measurements are desired but conditions make direct sensor location difficult. The sampling system is designed for use with any type of flow through gas transmitter, and is specifically designed for use with ATI's series A12, B12, or B12 Wet Stack type gas monitoring units.

The A21 sampling system is designed to draw gas samples to a measuring device located on the vacuum side of the system. This method is used to eliminate measurement errors that might arise due to sample contact with pumps, flowmeters, and other fittings that make up the complete system. An inlet filter holder is supplied with the unit to control the introduction of dust and particulate water into the system.

Figure 1 shows a typical A21 sampling system installation. Note that the sensor being used with this sampling system must be located between the inlet to the A21 and the sampling system filter element. Flexible PVC tubing may be used between the filter assembly and the sensor flowcell in most cases. The distance between these two devices should be kept as short as practical if the gas being monitored is highly reactive.

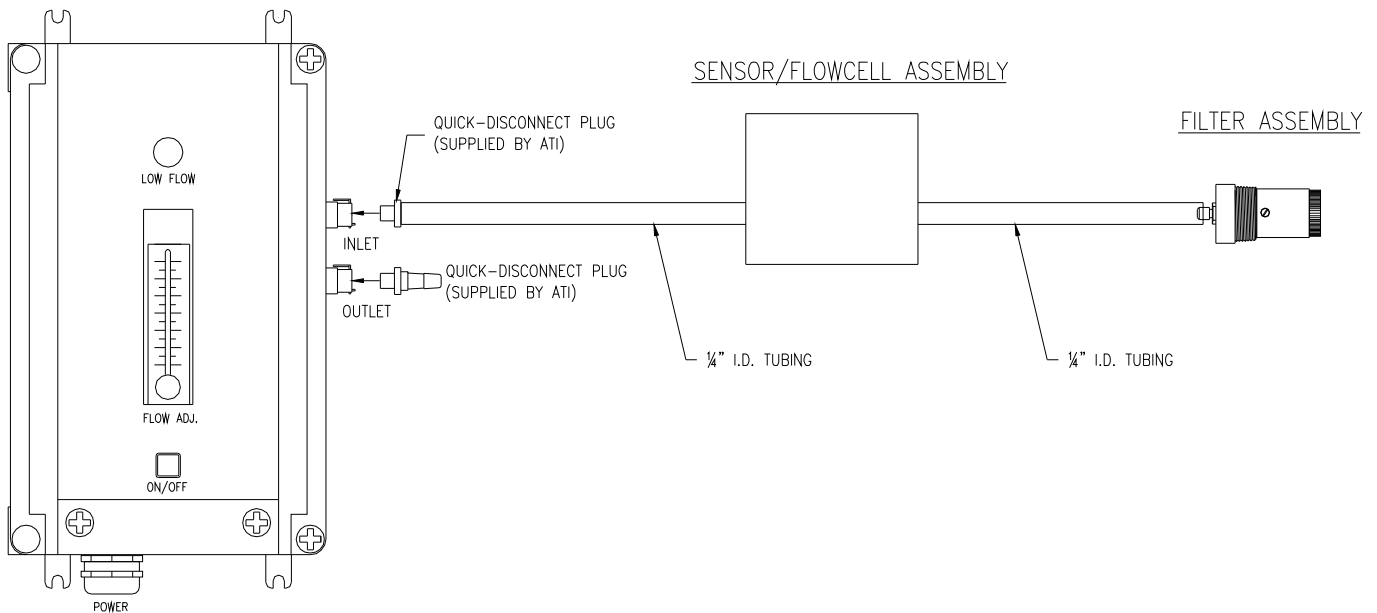

Figure 1 - Sampling System General Arrangement (ATI-0229)

SPECIFICATIONS

- Power:** 120 VAC, 50/60 Hz., 1 A
Or
12VDC, 1A max.
- Pump:** 12 VDC powered diaphragm type
- Flowrate:** Adjustable, 300 - 1000 cc/min., 500 cc./minute recommended
- Inlet:** Quick disconnect hose barb fitting for 1/4" I.D. flexible tubing
- Outlet:** Hose barb for 1/4" I.D. flexible tubing
- Alarms:** Low Flow alarm lamp on front panel
SPDT alarm relay for low flow for remote indication
SPDT power fail relay located on DC power supply (**120 VAC version only**)
- Enclosure:** NEMA 4X Fiberglass with clear polycarbonate window
- Temperature:** Operating: -10° to +45° C
Storage: -25° to +55° C
- Accessories:** 1 - Quick disconnect inlet fitting
1 - Inlet filter assembly
1 - Package of 10 replacement inlet filters
1 - 25 ft. length of PVC tubing

INSTALLATION

Installation of the A21 requires simply mounting the enclosure to a flat surface, connecting AC power to the internal power supply or DC Power straight into the T/B's, and connecting the sample tubing as required from the sampling system to the gas sensor and from the gas sensor to the inlet filter.

Figure 2 provides the dimensional details for the sampling system enclosure. At least 12 inches of free space should be maintained to the left of the enclosure to allow the front section to open on it's hinges.

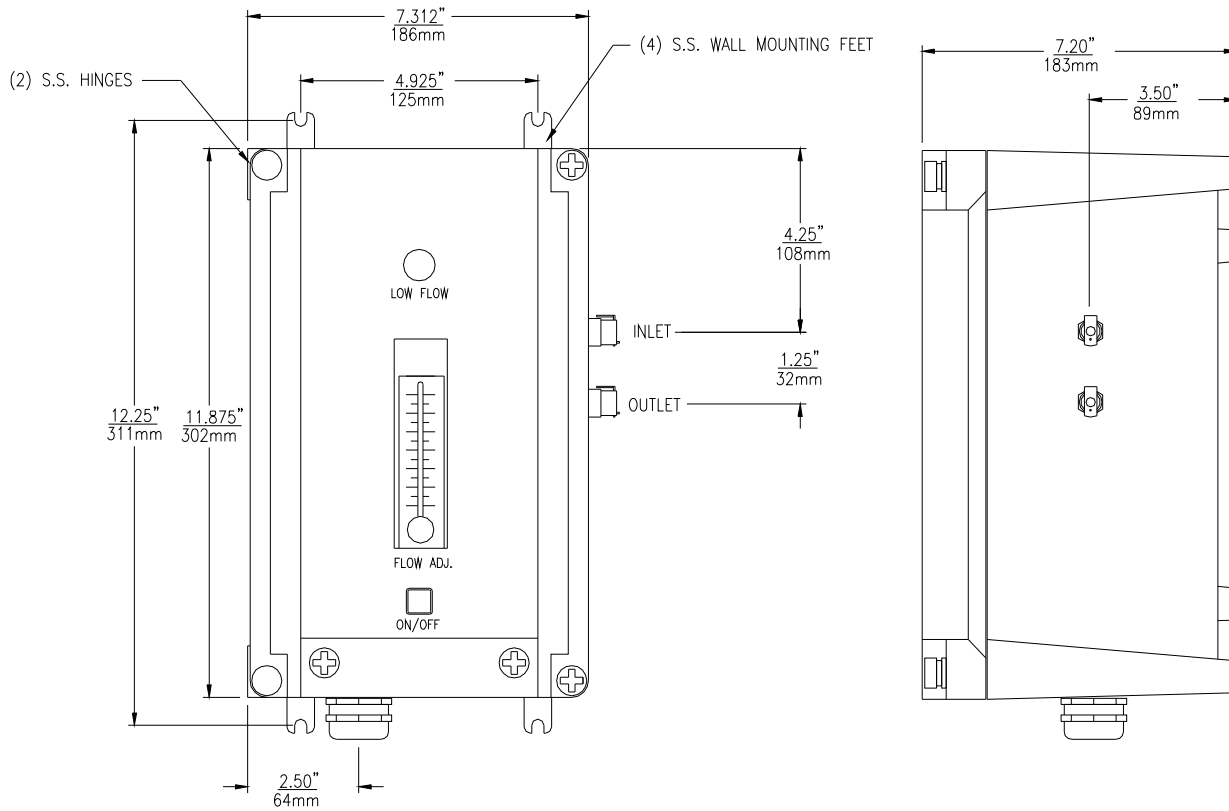

Figure 2 - Sampling System Enclosure Dimensions (ATI-0228)

After the sampling system has been mounted, connect inlet tubing from the gas sensor to the quick disconnect fitting supplied with the system. Plug the quick disconnect fitting into the port on the side of the enclosure. Check to see that the sample line connection at the sensor flowcell is tight so that air leakage does not occur at that point.

120 VAC Version

Power and alarm outputs are wired to the internal DC power supply and the auxiliary alarm relay used to remotely indicate low flow. Figure 3 indicates terminals for external connections.

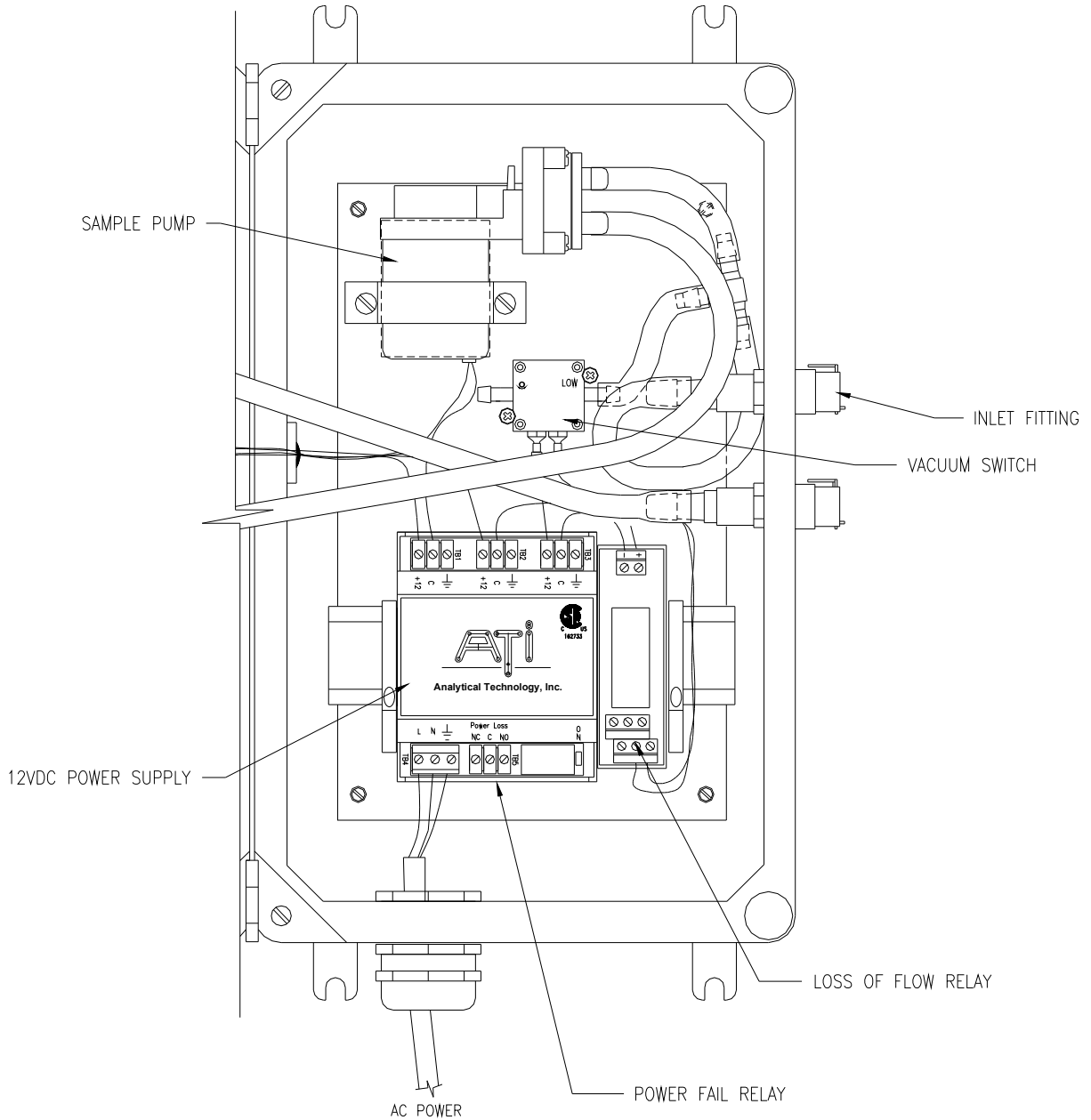

Figure 3 - Power and alarm output connections 120 VAC version (ATI-0230)

12 VDC Version

The alarm relay used to remotely indicate low flow, is wired internally. Figure 4 indicates terminals for external connections.

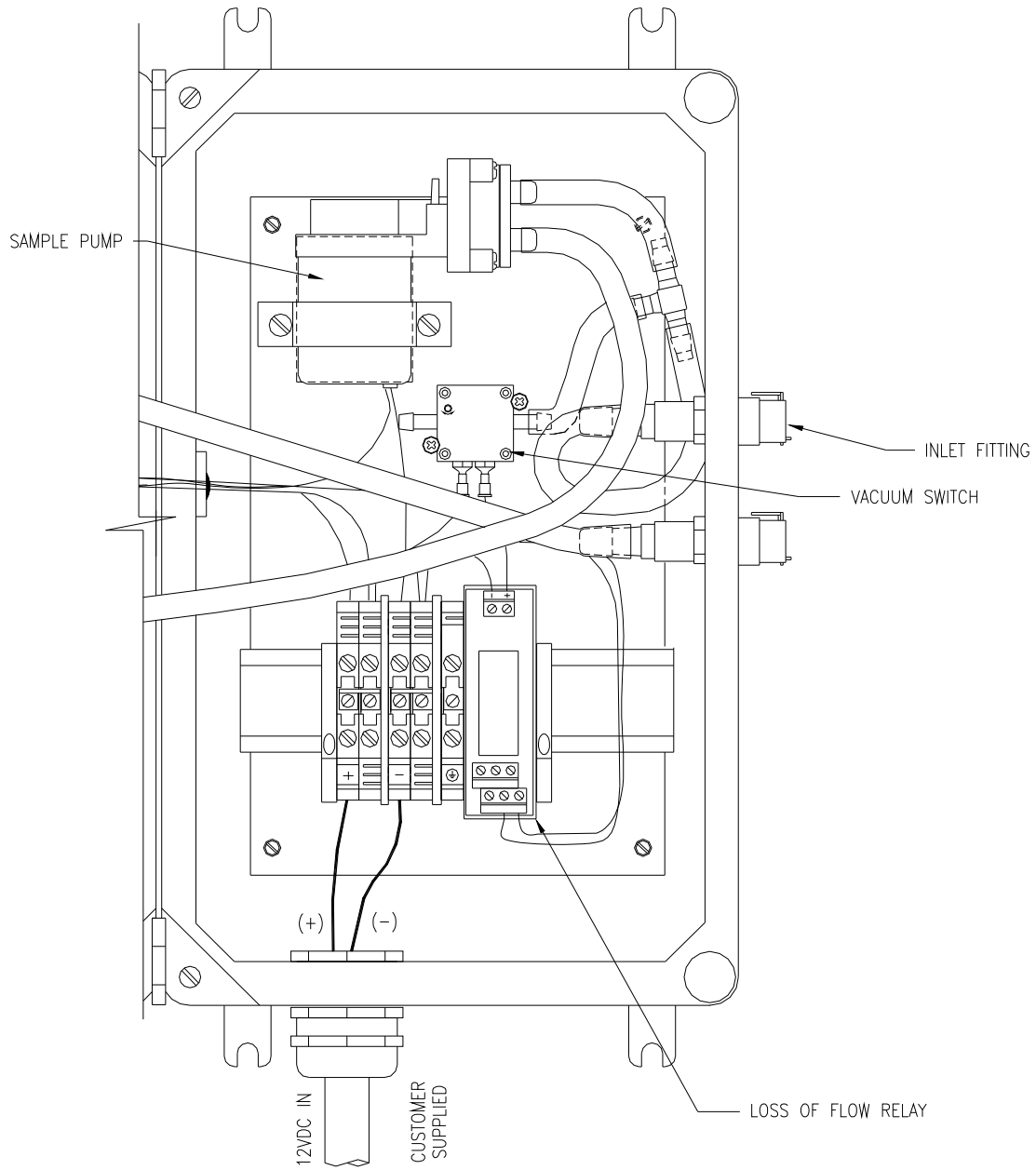

Figure 4 - Power and alarm output connections 12 VDC version (ATI-0331)

Optional Inlet Filter Assembly

A special fitting is available with the A21 sampling system to insure that excessive amounts of dirt or particulate water do not enter the system. The filter assembly consists of an inlet body and a replaceable membrane filter held in place by a screw on cap. A membrane is installed at the factory and a package of spare filters are supplied.

The inlet filter assembly is designed for either insertion into a duct or pipe, or to simply hang in an enclosed space. A 1 1/4" NPT pipe thread is provided near the back of the housing to adapt to pipes or ducts. The rear of the housing contains a 1/4" I.D. soft tube fitting for sample line connection.

The filter replacement interval will depend on the severity of the application. Most applications will require replacement every 2-3 months, while very dirty locations may require replacement every 2 or 3 weeks. If plugging is more serious than every 2 weeks, contact ATI for possible solutions.

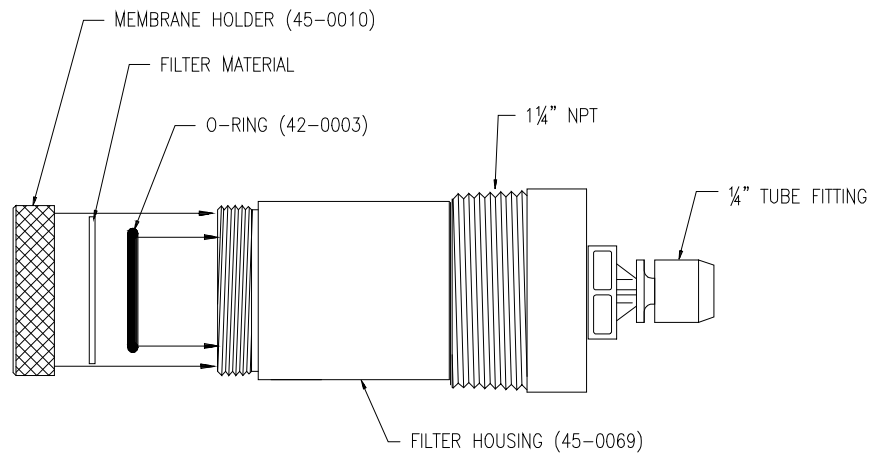

Figure 5 - Inlet Filter Assembly (ATI-0231)

OPERATION

Once AC or DC power has been wired and the sampling lines connected, the sampling system can be activated. A power switch on the front panel of the system is used to operate the diaphragm sampling pump. Press the ON/OFF switch and you should immediately hear the pump begin to run.

As previously noted, the sampling system draws sample through the external gas sensor and through the internal flowmeter on the vacuum side of the sample pump. The system flow rate is set by adjusting the rotameter on the front panel. The flowrate should be set to 500-600 cc/min. for most applications. The pump is capable of pulling up to 25" H₂O vacuum on the inlet at a flowrate of 700 cc/min.

Other than the flowrate adjustment, there are no other adjustments required for the system.

Low Flow Alarm

Incorporated into the sampling system is a low flow alarm designed to detect when the inlet vacuum has increased to the point where a loss of sample flow occurs. A lamp on the front panel will indicate this condition, and a SPDT relay inside the enclosure may be used to provide a remote indication of loss of flow.

At startup, it is a good idea to verify that the flow alarm is functional. To do this, block the flexible sample tubing between the inlet filter and the sensor flowcell. This will cause the pump to begin drawing a vacuum on the inlet line and will cause the flow to drop. The amount of time it takes for the lamp to come on will depend on the sample line length, but normally should come on within one minute. If blocking the sample line does not cause the flowrate to drop to zero, air leakage into the inlet line is indicated. Check all fittings to be sure tubing connections are leak free.

Power Failure Alarm (120 VAC version only)

The DC power supply inside the sampling system contains a relay which may be used to remotely indicate the loss of AC power to the sampling system. When AC power fails, the "Power Fail" relay shown in Figure 3 will change state, and suitable contact wiring may be used to remotely alarm the power loss condition.

SPARE PARTS

<u>Part No.</u>	<u>Description</u>
05-0026	Inlet Filter Disk, Package of 10
00-0055	Power Supply Module
00-0703	Inlet Filter Assembly
25-0004	Relay Module
26-0005	Pump On/Off Switch
26-0006	Vacuum Switch
36-0009	Sample Pump
39-0003	Low Flow Alarm Lamp
42-0003	Membrane o-ring
44-0085	Inlet and Outlet Fitting Body
44-0067	Inlet Fitting Plug (1/4" Tube)
44-0086	Outlet Fitting Plug (3/16" Tube)
45-0010	Membrane Holder
55-0014	Rotameter